

Principle of Operation

Flow is measured in terms of dynamic force acting on a target (solid disk) in the flow stream. Hermetically sealed, bonded strain gages in a bridge circuit configuration mounted outside the flow stream translate force into an electrical output. This output is proportional to flow rate squared.



Figure 1. Sanitary Target Flowmeter with Model 1050 Enclosure

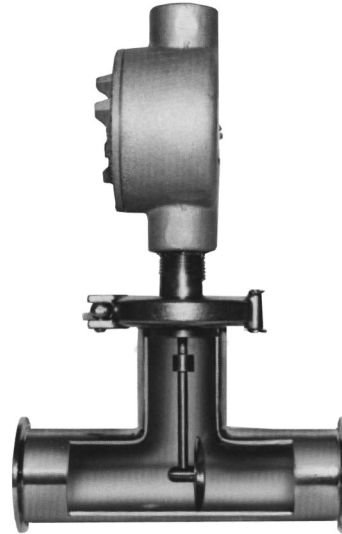

Figure 2. Sanitary Target Flowmeter cutaway with conduit enclosure

Accessories



Figure 3. Model 1030AW Indicator/Totalizer



Figure 4. Model 1530AW Mass flow computer

Benefits

Easy to Install and Field Calibrate	Simple field calibration to verify accuracy. Strain gage does not require flow test verification. Standard sanitary tri-clamp connections
Reliable	3A Approved/CIP No moving parts to wear
Fast Response Time	Typically less than 2 msec.

Technical Information

Functional Specifications

Fluid Types	Steam, Gas, Liquid
Pressure	Primary sensing elements: 5,000 psi max (345 bar)
Temperature	-65° to 425° F (-54° to 218° C) std. -65° to 500° F (-54° to 260° C) extended temp. -320° to 250° F (-195° to 121° C) cryogenic -65° to 300° F (-54° to 149° C) high sensitivity
Excitation Voltage (max)	15 VDC
Bridge Resistance	350 ohm \pm 5 ohm
Operational Range	Reynolds #s of >1000

Physical Specifications

Materials of Construction	
Seals	Teflon® std.
Sensing Element	316 SS/MP35N
Housing	316L SS
Connections	316L SS
Electronics Housing	Polyester coated aluminum
Options	Other materials
Connections & Mountings	
Mounting Position	Vertical, Horizontal, Angle
Typical Straight	Upstream: 10 x D
Pipe Requirements	Downstream: 5 x D
Process Connections	Clamp Fittings
Electrical Connection	¾" FNPT

Performance Specifications

Accuracy	Steam: \pm 1.0% of rate Liquid: \pm 1.0% of rate std Gas: \pm 1.0% of rate
Repeatability	\pm 0.15% of rate
Flow Turndown Ratio	Steam - 10:1 Gas - 10:1 Liquid - 10:1
Response Time	0.002 to 0.1 sec (transmitter dependent)
Flow Direction	Unidirectional: Standard Bidirectional: Optional - dual Model 1050 transmitters required
Agency Approvals (see transmitters)	3A

Selection and Sizing

All flowmeters are sized using an equivalent water flow. It is necessary to calculate what water flow produces a force on the target equal to the user's actual full-scale fluid flow. The following formulas are used to calculate the water flow equivalents.

Note: The Target 3-A Sanitary Flowmeter should only be used in those applications where the flow line can be filled slowly at start-up. High flow rates in an empty line may cause damage to the flowmeter. Flow ranges are for maximum rates under any conditions, including sanitizing and cleaning in place.

Note: Targets are welded, so be sure that your flow range is correct.

Gases	$\text{gpm} = \frac{\text{SCFM}}{22.7194} \sqrt{\frac{(S_g) (T)}{P'}}$ $\text{gpm} = (1.5564) (\text{ACFM}) \sqrt{\frac{(S_g) (P')}{T}}$
Steam	$\text{gpm} = \frac{\text{pph of steam}}{63.345} \sqrt{V_g}$
Liquid	$\text{gpm} = \text{gpm}_1 \sqrt{S}$ <p>Reynolds number must be greater than 1000 throughout entire flow range for liquids</p>

Table 1

$$R_e = \frac{(3160) (\text{gpm}_1)}{(d)(v)}$$

P' = Operating pressure in psia (psig + 14.696)

gpm₁ = Full-scale gpm of actual liquid

d = Actual internal pipe diameter (inches)

v = Viscosity in centistokes

SCFM = Full-scale standard cubic feet per minute

ACFM = Full-scale actual cubic feet per minute

R_e = Full-scale Reynolds number

S = Specific gravity liquid

S_g = Specific gravity gas

V_g = Specific volume of steam in cubic feet per pound

T = Operating temperature in degrees

R (degrees F + 459.67)

Note: Standard conditions are considered to be

14.696 psia and 60° F (519.67° R).

Air = 0.0764 lbs/ft³

Water = 62.3714 lbs/ft³

Flowmeter Pressure Rating

Pressure - Temperature Ratings

Maximum Pressure in psig

Based on clamp provided with meter.

For higher pressure rating contact factory

Tube Size (in)	Max psig	
	-100 to 70°F	250°F
3/4	500	250
1	500	250
1 1/2	500	250
2	450	250
3	350	150
4	200	125

Table 2

Flow Ranges

All flowmeters are sized using an equivalent water flow (see page 20).

LIQUID APPLICATION GPM EQUIVALENTS FOR SANITARY METER

Minimum and maximum flow rates to achieve accuracy
Higher flow rates per line size available. Contact factory.

Tube Size (in)	RANGE A				RANGE B				Full Scale PRESSURE DROP PSI (kg/cm ²)
	Min Flow GPM	Max Flow GPM	Min Flow LPM	Max Flow LPM	Min Flow GPM	Max Flow GPM	Min Flow LPM	Max Flow LPM	
0.75	2.70	27.00	10.22	102.20	2.70	27.00	10.22	102.20	15.0 (1.05)
1.00	2.70	27.00	10.22	102.20	4.50	45.00	17.03	170.34	10.0 (.70)
1.50	7.00	70.00	26.50	264.97	11.30	113.00	42.77	427.74	5.0 (.35)
2.00	13.00	130.00	49.21	492.09	21.00	210.00	79.49	794.91	3.5 (.25)
3.00	30.00	300.00	113.56	1135.59	40.00	400.00	151.41	1514.12	2.0 (.14)
4.00	55.00	550.00	208.19	2081.92	70.00	700.00	264.97	2649.71	1.0 (.07)

Table 3

Dimensions

DIMENSIONS			
Size	A	B	Product Wt. (lbs.)
3/4"	2 5/8"	5 1/4"	3
1	2 3/8	4 3/4	3
1-1/2	2 3/4	5 1/2	3
2	3 1/2	7	4
3	3 1/4	7 1/2	5
4	4 1/2	9	6

Table 4

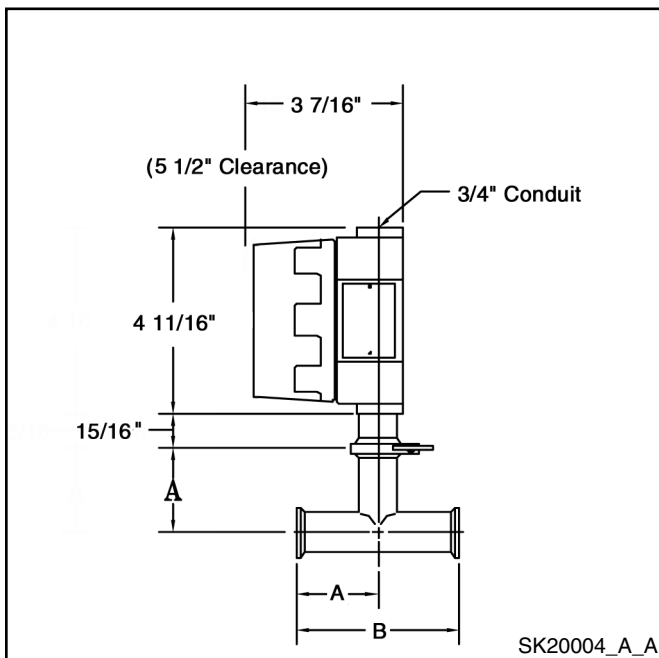

Figure 5. With TWS or TWL transmitter dimensions

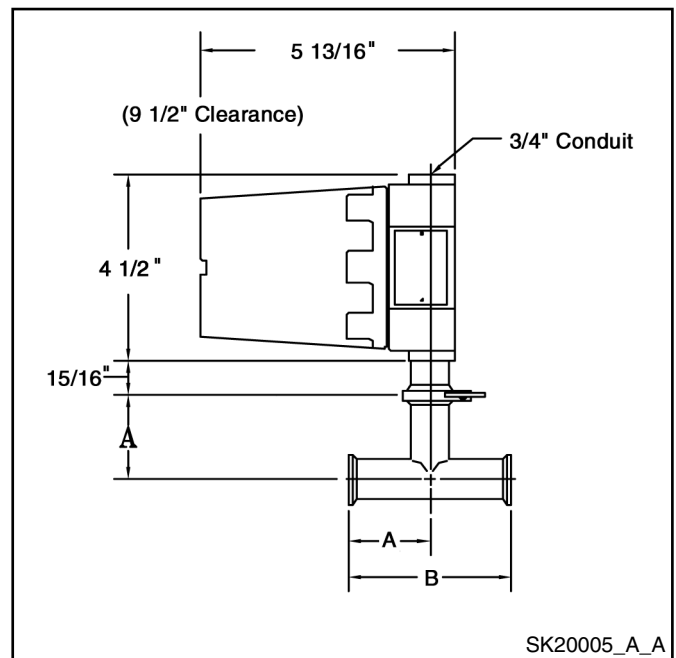
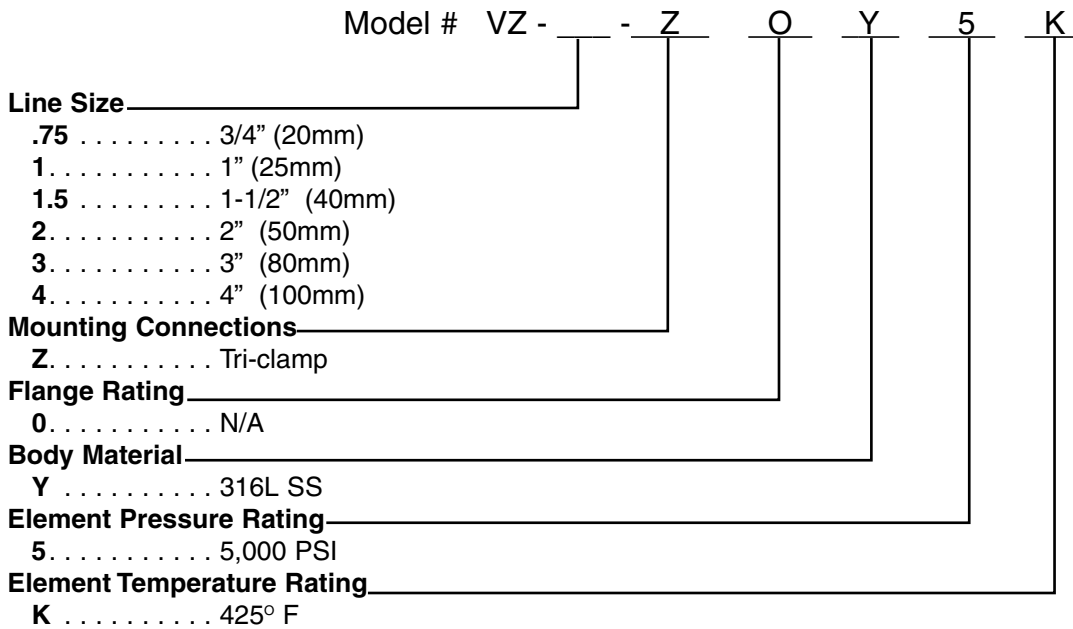

Figure 6. With 1050 or 1060 transmitter dimensions

Ordering Information

Please provide completed application data sheet (found at www.aaliant.com) to allow us to confirm selection.

1. After calculating the water flow rate equivalent, refer to the range chart on page 21.
2. If the water flow rate equivalent falls between the A and B flow rate in the range charts, a 10:1 flow range of the actual user's flow may be obtained.
3. Select line size.
4. Confirm maximum pressure capability of clamp/meter rating with process conditions from Table 2.
5. Confirm suitability of materials of construction (see page 19).
6. Confirm maximum temperature capability of line size from Table 2.
7. Confirm suitability of standard local mounted electronics. Ambient temperature at electronics not to exceed 140° F. Select transmitter model from pages 23-29. Specify if remote mounted electronics are required.
8. Provide: Fluid, Fluid Viscosity, Minimum & Maximum Operating Pressure, Minimum & Maximum Operating Temperature, Density/Specific Gravity or Specific Volume.
9. Provide minimum and maximum flow range. Targets are custom sized to each application allowing a full turndown from actual maximum flow.



Options

- Remote Mount Electronics: Up to 100 ft (30m) (transmitter dependent)