

LIQUID CONTROLS SPONSLER, INC.



PRECISION TURBINE FLOWMETERS

LIQUID AND GAS MEASUREMENT

BATCHING

BLENDING

FILLING

PROCESS CONTROL



SPONSLER PRECISION TURBINE FLOWMETERS

Sponsler precision turbine flowmeters measure volume using a precision-crafted, hydraulically-balanced rotor in the flow stream. The AC sine-wave output of the rotor is translated into useful flow rate data by Sponsler flow totalizers and batching systems. Sponsler precision turbine flowmeters are manufactured to handle a variety of applications including high pressures and hazardous liquids and gases. For more than 30 years, the compact and rugged design of Sponsler precision turbine flowmeters have set the industry standard in flow measurement for high accuracy and reliability under severe operating conditions.

Features

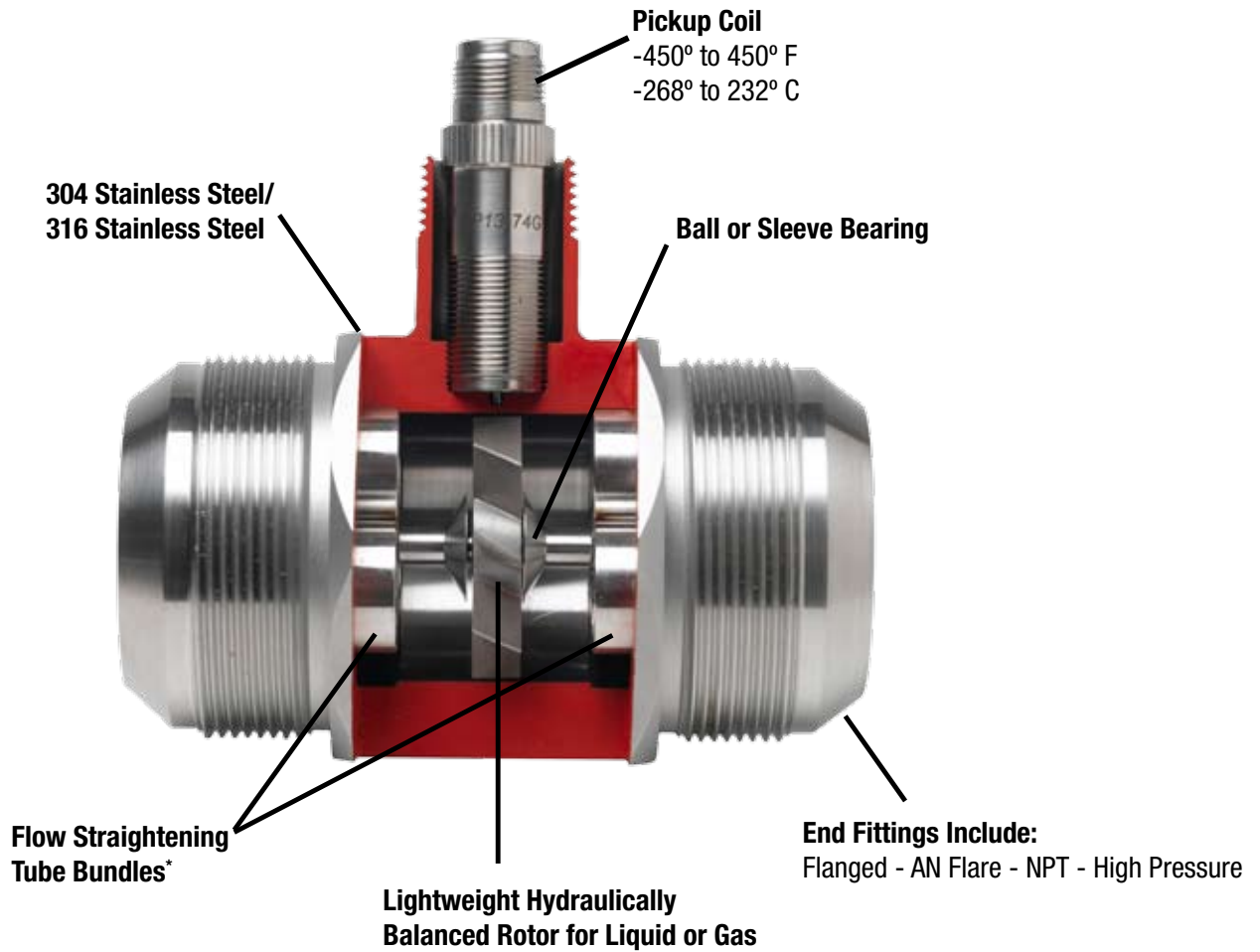

- Performs well in high pressure applications
- Wide range of materials of construction available
- Interfaces with electrical, electro-mechanical, or completely automated systems
- Manufactured in the USA
- Custom design and system engineering service
- Wide choice of bearings
- NIST approvals for solvent, gasoline, diesel, ethanol, and fuel oil (1" through 4")
- Measurement Canada approvals for solvents and gasoline (1½" through 3")

* Still requires 10D upstream and 5D downstream

SPONSLER PRECISION TURBINE FLOWMETERS

Performance Curves

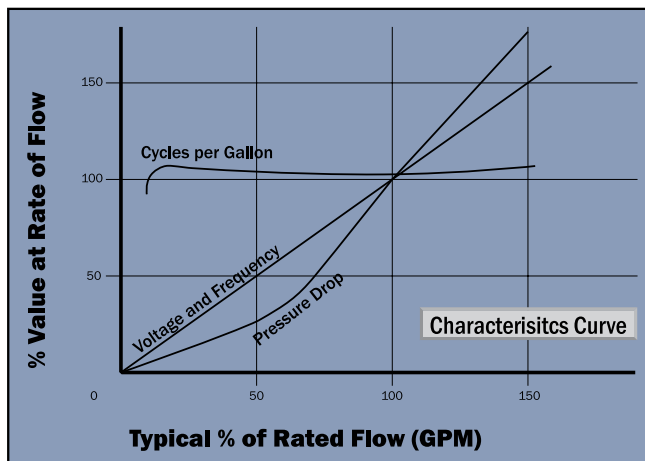
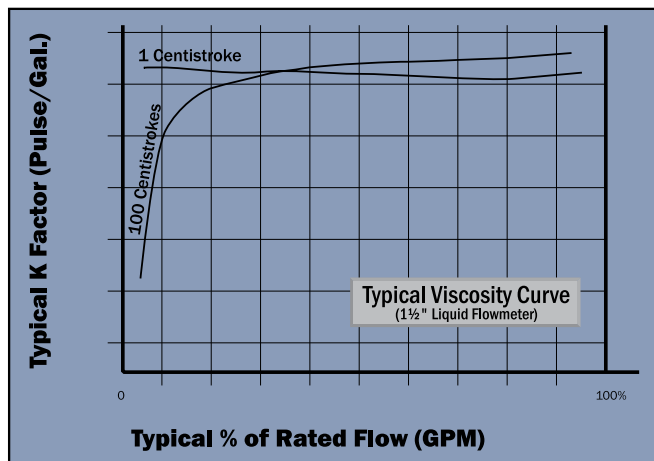

Typical Arrangement of Flowmeter and Readout Instrument

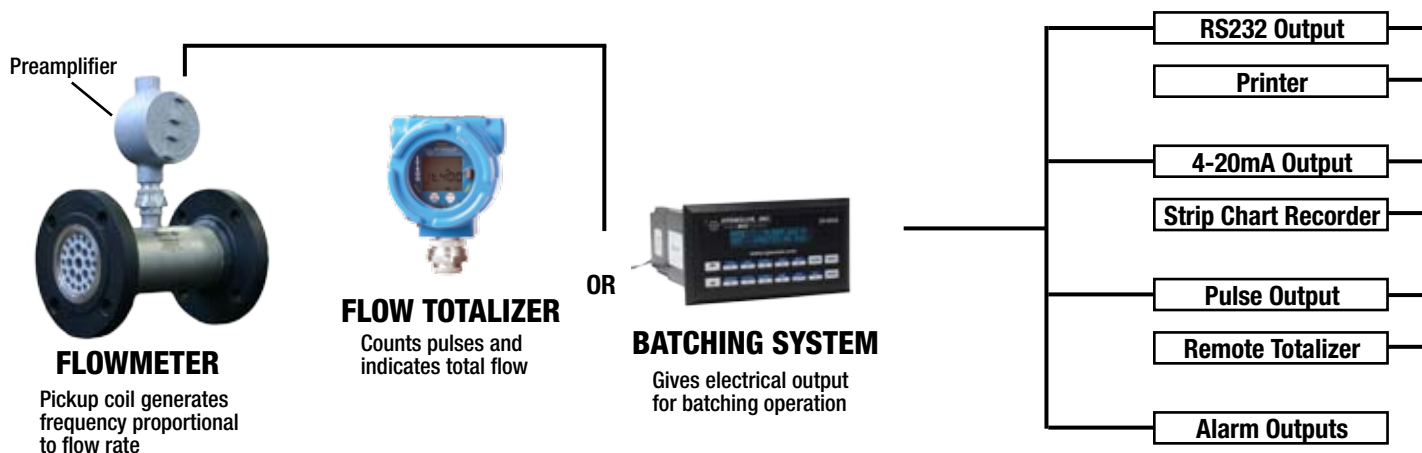

Model Selection Guide

SIZE	BEARING TYPE	ROTOR TYPE	ENDFITTING TYPE	MATERIAL	OPTIONS
	CB Cryo Ball MB Metal Ball TS PTFE Sleeve* GS Graphitar Sleeve* CS Carbide Sleeve* FS Flourosint Sleeve*	NL 304 Nickel Liquid ¹ PHL 17-4 PH-SS Liquid PH7 17-4 PH-SS 7 Degree	A NPT FA FNPT ² B AN Flare C 150C D 150S E 300C F 300S J 600C K 600S H High Pressure	4 304SS 6 316SS	HT Hi-Temp. FB Mod. Carr. X Mnt. Boss

EXAMPLE:



* Not available in 1/4"

¹ Cryogenic liquids only

² Overall lengths vary (consult factory)

Typical Liquid Applications

- Cryogenics
- Allyl Chloride
- Adipic Acid
- Chloride Leftovers
- Gasoline
- LPG
- Brine
- Anhydrous Ammonia
- Mercaptans
- Ethylene Diamine (EDA)
- Ethylene Dichloride
- Asphalt
- Water, Fresh
- Water, DI
- Water, Salt
- Perchloroethylene
- Carbon Tetrachloride
- Fuel Oils
- Freon
- Ethanol



Specifications

Linearity

+/- 0.5%

Premium Linearity

+/- 0.25% (over a specified range)

Repeatability

+/- 0.1%

Premium Repeatability

+/- 0.02% (over a specified range)

Temperature

-450° to 450° F (-267° to 232° C) standard, 1000°F available

Flow Ranges

0.35 to 12,000 GPM (1.32 to 45425 LPM)

Pressure Drop

4 PSI at nominal rated flow range

Materials

300 and 400 series stainless steel. A variety of other materials to satisfy most applications including CPVC for corrosive applications (See Bulletin 5003).

Electrical Output

A minimum of 30 mV peak to peak at the minimum repeatable flow.

End Fittings

Include AN series 37°, flare tube (MS-33656), NPT, and ANSI flanges. Other end fittings available on request.

Operating Pressure

Accommodates wide range of pressures depending on end fittings.

Calibration

Precision turbine flowmeters furnished with standard fluid calibration. Special calibrations available.

NOMINAL METER SIZE	NOMINAL FLOW RANGE U.S. Gallons (Liters) Per Minute				APPROX. METER FACTOR "K" Pulses/ U.S. Gallon (Liter)	APPROX. METER WT. lbs./kg
	Minimum Repeatable	Minimum Linear	Nominal Maximum	Extended Maximum		
¼" (6.4mm)	0.1 (.38)	0.35 (1.32)	3.5 (13.25)	3.5 (13.25)	14650 (3871)	2/1
⅜" (6.4mm)	0.35 (1.32)	0.75 (2.84)	5 (18.92)	7 (28.4)	6885 (1819)	2/1
½" (13mm)	0.6 (2)	1.25 (5)	9.5 (36)	12 (45)	6912 (1758)	2/1
⅝" (15mm)	0.9 (3)	1.75 (7)	16 (61)	18 (68)	4043 (1110)	2/1
¾" (17mm)	1.75 (7)	2.5 (10)	29 (110)	35 (133)	1684 (445)	4/2
1" (25mm)	3 (11)	4 (15)	60 (227)	75 (284)	726 (192)	5/2.5
1¼" (32mm)	4 (15)	6 (23)	93 (352)	115 (436)	324 (86)	7/3
1½" (38mm)	6 (23)	8 (30)	130 (492)	175 (662)	200 (53)	8/3.5
2" (51mm)	12 (45)	15 (57)	225 (851)	275 (1041)	149 (39)	13/6
2½" (64mm)	15 (57)	25 (95)	400 (1514)	500 (1893)	81 (21)	18/8
3" (76mm)	30 (114)	40 (151)	650 (2460)	800 (3028)	47 (12)	19/8.5
4" (76mm)	50 (189)	75 (284)	1250 (4732)	1500 (5678)	21 (6)	36/16
5" (127mm)	100 (379)	140 (530)	2000 (7571)	2500 (9464)	9 (2.4)	47/21
6" (152mm)	125 (473)	200 (757)	2900 (10978)	3600 (13627)	5.6 (1.5)	58/26
8" (203mm)	280 (1060)	330 (1249)	5200 (19684)	6400 (24227)	4.3 (1.1)	119/54
10" (254mm)	550 (2082)	650 (2461)	8000 (30283)	9800 (37097)	2.13 (0.6)	225/103
12" (305mm)	800 (3028)	900 (3407)	12000 (45425)	15000 (56781)	1.29 (0.3)	345/157

Typical Gas Applications

- Argon
- Nitrogen
- Oxygen
- Air
- Ammonia
- CO₂
- Ethylene
- Helium
- Hydrogen
- Methane
- Methylchloride
- Nitric Oxide
- Nitrous Oxide
- Steam (Consult Factory)
- Acetylene



SCFM to ACFM Conversions

Sponsler precision turbine gas flowmeters are designed to measure actual cubic feet or actual volume passing through the meter. Before sizing a flowmeter it is necessary to convert flow units (i.e. SCFM, LPM, etc.) to actual units. To convert to actual measured volume (ACFM) from standard volume (SCFM) use the **Application Tools** page at www.sponsler.com or use the following formula:

$$ACFM = SCFM \times 14.7/Pa \times Ta/530$$

ACFM = actual cubic feet per minute measure gas flow

SCFM = standard cubic feet per minute gas flow

Pa = operating pressure in (PSIA)

$$= PSIG + 14.7$$

Ta = temperature in degrees Rankine = F + 460

Specifications

Accuracy

+/- 1% of full scale

Repeatability

+/- 0.25%

Temperature Range

-450° to 450° F (-267° to 232° C) standard,
1000°F available

NOMINAL METER SIZE	FLOW RANGE ACFM - Magnetic Pickup		EXTENDED FLOW RANGE ACFM - MC Pickup w/ SP717 Amplifier		APPROX. METER FACTOR "K" Pulses	APPROX. METER WT. lbs./kg
	Minimum Linear	Maximum Linear	Minimum Repeatable	Maximum Repeatable		
¼" (6.4mm)	0.35	3.5	0.2	3.5	5129	2/1
⅜" (6.4mm)	0.75	5	0.5	10	1842	2/1
½" (13mm)	1	10	0.8	12	1772	2/1
⅝" (15mm)	2	20	1.5	20	1475	2/1
¾" (17mm)	2.5	28	2.0	30	467	4/2
1" (25mm)	4	60	2.8	75	203	5/2.5
1¼" (32mm)	6	100	3.0	100	94	7/3
1½" (38mm)	8	130	5.0	150	56	8.35
2" (51mm)	15	250	11	250	32	13/6
2½" (64mm)	25	450	15	500	17	18/8
3" (76mm)	40	650	-----	-----	9	19/8.5
4" (76mm)	75	1200	-----	-----	4.6	36/16
5" (127mm)	150	1800	-----	-----	CF	47/21
6" (152mm)	250	2900	-----	-----	CF	58/26
8" (203mm)	330	5000	-----	-----	CF	119/4
10" (254mm)	650	7500	-----	-----	CF	226/103
12" (305mm)	900	12000	-----	-----	CF	345/157

INSTALLATION DIMENSIONS

End Flanged (Sizes 1/4" - 12") Stainless steel unless specified differently

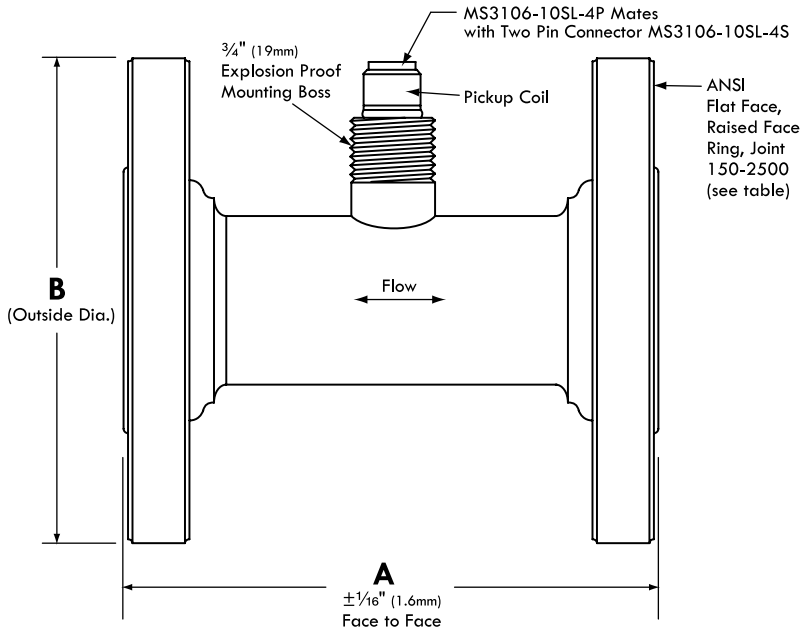

Meter size based on normal inside diameter of pipe.

Special flanges can be provided to specification.

For hazardous areas, pickup coils with an explosion proof housing can be provided.

All flowmeters 5/8" and smaller will be provided with 1/2" end connections unless otherwise specified.

LINE SIZE	150#		300#		600#		900#		1500#		2500#	
	A	B	A	B	A	B	A	B	A	B	A	B
1/4-1/2"	5"	3 1/2"	5"	3 3/4"	5"	3 3/4"	7"	4 3/4"	7"	4 3/4"	7"	5 1/4"
5/8"	5 1/2"	3 1/2"	5 1/2"	3 3/4"	5 1/2"	3 3/4"	7"	4 3/4"	7"	4 3/4"	7"	5 1/4"
3/4"	5 1/2"	3 7/8"	5 1/2"	4 5/8"	5 1/2"	4 5/8"	7"	5 1/8"	7"	5 1/8"	7"	5 1/2"
1"	5 1/2"	4 1/4"	5 1/2"	4 7/8"	5 1/2"	4 7/8"	8"	5 7/8"	8"	5 7/8"	8"	6 1/4"
1 1/4"	6"	4 5/8"	6"	5 1/4"	6"	5 1/4"	8"	6 1/4"	8"	6 1/4"	8"	7 1/4"
1 1/2"	6"	5"	6"	6 1/8"	6"	6 1/8"	9"	7"	9"	7"	9"	8"
2"	6 1/2"	6"	6 1/2"	6 1/2"	6 1/2"	6 1/2"	9"	7"	9"	7"	9"	8"
2 1/2"	7"	7"	7"	7 1/2"	7"	7 1/2"	10"	9 5/8"	10"	9 5/8"	10"	10 1/2"
3"	10"	7 1/2"	10"	8 1/4"	10"	8 1/4"	10"	9 1/2"	10"	10 1/2"	11"	12"
3 1/2"	12"	8 1/2"	12"	9"	12"	9"	-	-	-	-	-	-
4"	12"	9"	12"	10"	12"	10 3/4"	12"	11 1/2"	12"	12 1/4"	15"	14"
5"	14"	10"	14"	11"	14"	13"	14"	13 3/4"	14"	15 1/2"	16"	19"
6"	14"	11"	14"	12 1/2"	14"	14"	14"	15"	14"	15 1/2"	16"	19"
8"	16"	13 1/2"	16"	15"	16"	16 1/2"	16"	18 1/2"	16"	19"	18"	21 3/4"
10"	20"	16"	20"	17 1/2"	20"	20"	20"	21 1/2"	20"	23"	22"	26 1/2"
12"	24"	19"	24"	20 1/2"	24"	22"	24"	24"	24"	26 1/2"	24"	30"

AN Flared Tube (Sizes 1/4" - 2")

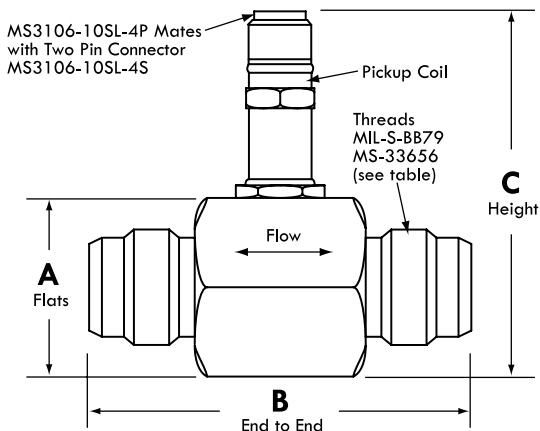

LINE SIZE	DIMENSIONS (inches)			END CONNECTIONS	APPROX. WT. lbs/kg
	A	B	C		
1/4-1/2"	1 1/8"	2 9/16"	3"	3/4-16 UNJF-3A	.38/.173
5/8"	1 1/8"	2 3/4"	3"	7/8-14 UNJF-3A	.75/.341
3/4"	1 5/8"	3 1/4"	3 1/2"	1 1/16-12 UNJF-3A	.75/.341
1"	1 5/8"	3 1/2"	4"	1 5/16-12 UNJF-3A	1.3/.627
1 1/4"	2"	3 7/8"	4 5/8"	1 5/8-12 UNJF-3A	1.75/.795
1 1/2"	2 1/8"	4 3/8"	4 5/8"	1 7/8-8 UNJF-3A	2.31/1.05
2"	2 3/4"	4 3/4"	5 3/8"	2 1/2-12 UNJF-3A	3/1.36

INSTALLATION DIMENSIONS AND PRESSURE DROPS

MNPT (Sizes 1/4" - 4")

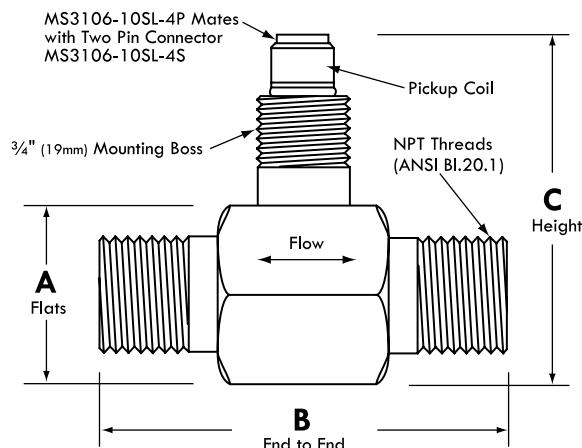

LINE SIZE	DIMENSIONS (inches)			END CONNECTIONS	APPROX. WT.
	A	B	C	MNPT	lbs/kg
1/4-1/2"	1 1/8"	3"	3"	1/2"	.38/.173
5/8"	1 1/8"	3"	3"	1/2"	.75/.341
3/4"	1 5/8"	3 1/4"	3 1/2"	3/4"	.75/.341
1"	1 5/8"	3 1/2"	4"	1"	1.3/.627
1 1/4"	2"	3 7/8"	4 3/8"	1 1/4"	1.75/.795
1 1/2"	2 1/8"	4 3/8"	4 5/8"	1 1/2"	2.31/1.05
2"	2 3/4"	4 3/4"	5 3/8"	2"	3/1.36
2 1/2"	3 1/4"	6 1/16"	5 3/8"	2 1/2"	5.5/2.50
3"	3 1/2"	10"	5 3/8"	3"	10/4.54
4"	4 1/2"	12"	7"	4"	14/6.35

Gross Pressure Drop Characteristics Chart depicts characteristics of H₂O

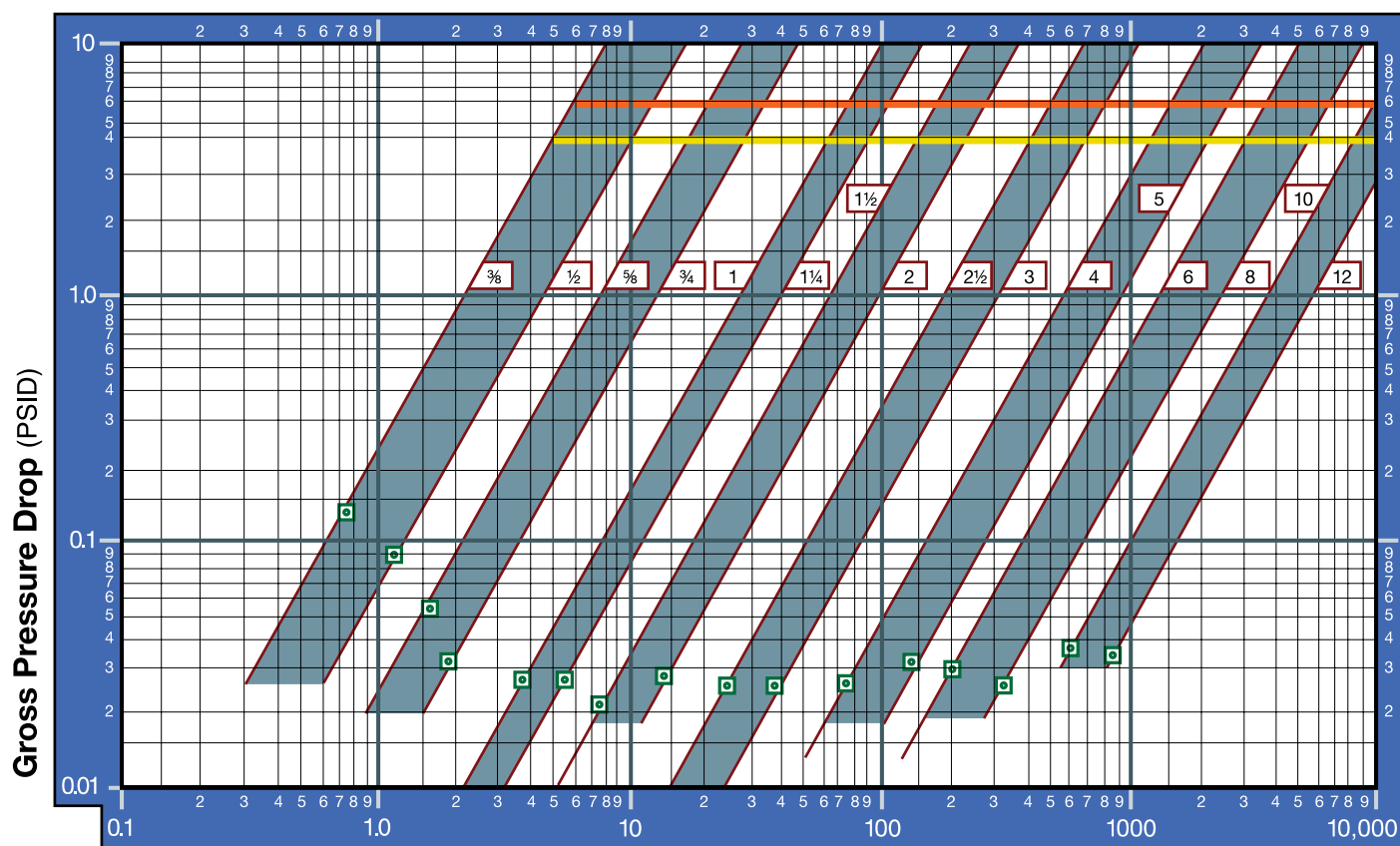

- = Minimum Linear Flow
- = Nominal Rated Flow
- = Extended Maximum Flow
- = Flowmeter Size (inches)

To Estimate Liquid ΔP (at room temperature)

$$P = \Delta\mu^{1/4} \times SG^{3/4} \times \Delta P \text{ (on chart above)}$$

$$* \mu (cP) = \nu (cSt) \times SG$$

To Estimate Gas ΔP (at densities other than 1 lb./ft.³)

$$\Delta P = \rho (\text{lbs./ft.}^3) \times \Delta P \text{ (on chart above)}$$

μ = Dynamic (Absolute) Viscosity • cP = Centipoise • SG = Specific Gravity • ν = Kinematic Viscosity • cSt = Centistokes • ρ = Density

The Application Tools page at www.sponsler.com contains a Liquid Pressure Drop Calculator

LIQUID CONTROLS GROUP

The Liquid Controls Group provides custody transfer solutions for the control and management of high-value fluids and gases. In 2001, IDEX combined Corken, Liquid Controls and Sampi to form the Liquid Controls Group. Together, they used their combined resources to design valuable new products and offer cost-effective pump and meter solutions. They laid the foundation for LCG's successful program of collaboration and innovation. With the additions of Liquid Controls Sponsler, Toptech Systems and Faure Herman, LCG quickly became a dependable, single source provider, large enough to supply comprehensive solutions yet flexible enough to customize solutions for unique needs. Today, the Liquid Controls Group has a strong global presence with seven business units in five countries, over 500 distributors on six continents, and six industry leading brands.



YOUR CUSTOMERS — OUR CUSTOMERS

The Liquid Controls Group (LCG) is part of the IDEX Corporation, a diversified, engineered products company. IDEX leverages the resources of high quality, similar-profile businesses to innovate solutions that bring real and lasting value to you, our customer. At LCG and IDEX, the voice of our customers is our driving force. We are committed to helping you develop better products and services to meet your customers' needs.

LIQUID CONTROLS

105 Albrecht Drive
Lake Bluff, IL 60044
(847) 295-1050

LIQUID CONTROLS EUROPE/SAMPI

Via Amerigo Vespucci 1
55011 Altopascio (Lucca), Italy
+39 0583 24751

LIQUID CONTROLS INDIA

808 VCCI Complex
GIDC Makarpura
Vadodara-390 101
Gujarat, India
+91 265 2631855

LIQUID CONTROLS SPONSLER

105 Albrecht Drive
Lake Bluff, IL 60044
(847) 295-1050

TOPTECH SYSTEMS

280 Hunt Park Cove
Longwood, FL 32750
(407) 332-1774

Nateus Business Park
Nieuwe Weg 1-Haven 1053
B-2070 Zwijndrecht (Antwerp), Belgium
+32 (0)3 250 60 60

FAURE HERMAN

Route de Bonnetable
B.P. 20154
72406 La Ferté-Bernard Cedex, France
+33 (0)2 43 60 28 60

6961 Brookhollow West Drive
Houston, TX 77040
(713) 623-0808

CORKEN

3805 Northwest 36th St.
Oklahoma City, OK 73112
(405) 946-5576

www.liquidcontrolsgroup.com



Copyright © 2009 Liquid Controls
Publication LT-5007

