

FLO-GAGE™

Description

The **RCM Flo-Gage™** is a direct reading flow meter with a large, easy to read dial calibrated in engineering units (GPM, SCFM, l/min, etc.). The **Flo-Gage™** measures flow based on a pressure differential created across a built-in calibrated nozzle. The meter is self-contained and complete. It does not require external power connections, separate orifices, or blocking, purging or equalizing valves.

The **Flo-Gage™** is suitable for measuring **water, oil and most other low viscosity liquids** which do not deposit out and which are compatible with the materials of construction.

The **Flo-Gage™** is also suitable for measuring **compressed air, oxygen, carbon dioxide and many other nontoxic compressed gases**. (Specify option I.) **Saturated steam** can also be measured up to 120 psig. (Option K).

The **Flo-Gage™** can be fitted with a two-wire transmitter to provide a current output for remote indication, recording or totalization, or with reed switch contacts for signaling high or low flows.

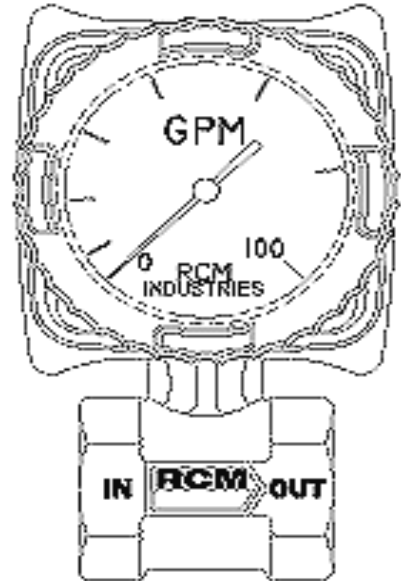

Features and Benefits

- Sturdy in-line metal construction to withstand piping stresses without breaking
- Black on white dial won't crack, glaze or become hard to read with age
- Expanded 3.5 " (90 mm) 270° analog dial for reading at a glance
- **Suitable** for use with both **opaque** and clear fluids
- Measures 6:1 range with 3% F.S. accuracy
- **Dial and case** factory configured for quick installation - but **easily field re-configured** if needed
- Liquid flow ranges from 4 GPH (15 l/h) in 1/2" meter to 3000 GPM (12000 l/m) in 8" meter
- Gas flow ranges from 40 SCFH (1 Nm³/h) in 1/2" meter to 20,000 SCFM (600 Nm³/m) in 8" meter

Applications

The **Flo-Gage™** flowmeter has been developed for industrial applications where durability and reliability are important considerations in the monitoring of flow. The **Flo-Gage** has accuracy for most industrial processes and is particularly suited for applications where compactness, low cost, minimal maintenance and resistance to accidental damage are important factors.

Typical applications include: **lube oil monitoring, blending processes, cooling water, reverse osmosis systems, and compressed air measurement.**

Specifications

	Standard	Options
Housing	Polycarbonate UV stabilized	None
Body	Bronze	Monel 316 SS
Bellows	Bronze	Monel 316 SS Inconel
Seals	Buna-N	Viton EPR Teflon
Crystal	Polycarbonate	None
Gear Movement	Bronze	316 SS
Flo-Gage		
Accuracy	± 3% F.S.	
Repeatability	± 1% F.S.	
Pressure		
Maximum	180 psig	400 psig
Minimum	10 psig	10 psig
Temperature		
Maximum	212°F	350°F
Minimum	-30°F	-80°F

Specifications (continued)

Transmitter Option	W,X,Y,Z	W2,W3
Accuracy		
Horizontal	±3% F.S.	±3% F.S.
Vertical	±5% F.S.	±3% F.S.
Minimum Flow Rate		
	30% F.S.	15% F.S.
Ambient Temp Limit		
	120F, 50C	120F, 50C
Current Output	4-20 mA	4-20 mA
Ohms max	800	650 (350 with R option)
Contact Rating (hi/lo)	3.0 amp @24 V 1.0 amp @ 117 V 0.5 amp @ 230 V	
Frequency Output	1000 Hz FS 5 V peak 270 μ on time	
Electrical Rating	General purpose	
Power Input	100 mA 25 mA (customer furnished) 24 Vdc 24 Vdc	
Reed Switches (Option 1S2, 2S2)		
Switches are field adjustable from 30% to 90% of full scale. Switches are independent and are easily adjustable with a phillips screwdriver. Switches are factory set to the flow rates specified or, if not specified to 30% and 90% of full scale.		
Setability	±5% F.S.	
Repeatability	±1% F.S.	
Hysteresis	7 to 13% F.S.	
Contact rating	3 watts	
Voltage	175 Vdc - max 245 Vac - max	
Current	250 mA max. switching 1.0 amp max carry	
Resistance		
Contact initial	ohms max 0.100	
Insulation	ohms min 1.0 x 10 ⁹	
Capacitance	picofarad-typ 1.0	

How to order

Selecting the **Flo-Gage** is easy ...and our factory staff is always glad to help!

Select a) body size, b) series, c) body material, d) direction of flow, e) full scale flow rate f) options (if required) and g) switches (if required).

- a) **BODY SIZE** - the pipe size at the meter inlet. See Dimension Table for available sizes.
- b) **SERIES** (end connections)
 - 7 – threaded units provided with FNPT connections standard. (FBSP parallel threads available on request for bronze and monel meters.)
 - 8 – wafer units mount between any standard 150 or 300 class flanges (or international equivalent).
 - 9 – Tri-Clover sanitary end connections for schedule 10 tubing
- c) **MATERIAL**
 - 1 = Bronze
 - 2 = Monel
 - 3 = Stainless steel (316)
- d) **FLOW DIRECTION** (L,R,VUL,VUR,VDL,VDR)
 - Select flow to Left, Right, Vertical Upflow dial on Left, Vertical Upflow dial on Right, Vertical Downflow dial on Left, Vertical Downflow dial on Right
- e) **FLOW RATE** (full scale gpm for liquid meters, SCFM for compressed gas meters) – Prefix full scale with “M” for metric units. Non-standard flow rates require option E.
- f) **OPTIONS** (if required) – Select from Table of Options below.
 - Note: For gas service, select option I and specify gas being measured, inlet temperature and pressure.*
- g) **SWITCHES** (if required)
 - 1S2 – One single pole double throw switch
 - 2S2 – Two single pole double throw switches

Example: 3/4-71-R-20-AD-1S2 is the catalog number for a 3/4" NPT Series 7000 Flo-Gage of bronze construction, flow direction from left to right, flow range of 20 GPM full scale, equipped with optional seals of Viton, optional gasketed case and one single-pole double throw reed switch.

Example	<u>3/4</u>	-	<u>7</u>	<u>1</u>	-	<u>R</u>	-	<u>20</u>	-	<u>AD</u>	-	<u>1S2</u>
	a		b	c		d		e		f		g

Table of Options

A	Viton seals	N	Ammonia service
B	EPR seals	R	Digital rate and total readout
B2	Teflon seals	R2	Remote readout, mechanical
C	Calibration for Specific gravity (specify)	T	High temperature service (212 to 350 F)
D	Gasketed case	V	High viscosity service (5 - 500 cps) (specify)
D2	Gasketed case with conduit	W	4-20 mA DC 4 wire linear signal
E	Non-standard flow rate	W2	4-20 mA DC 2 wire squared signal
ES	Low flow rate (Below 2 GPM)	W3	4-20 mA DC 2 wire squared signal without local indicator
G	Custom scales and dials	X	Hi/Lo alarm relays
H	High pressure service (180-400 psig)	Y	Frequency output (5 v. peak, 270 μs on time)
I	Compressed gas service (specify gas, inlet temperature and pressure)	Z	Combination of options
J	Peak flow indicator		W, X, & Y
K	Saturated steam service		

Standard Flow Rates & Body Sizes

Series 7000 (threaded) and
Series 8000 (wafer)

Size		Full Scale Flow Range			
in	mm	liquid		gas (option I)	
		GPM	l/m	SCFM	Nm ³ /h
1/4	08	2	8	10	15
		3	15	20	30
		4	25	30	50
1/2	15	2	8	10	15
		3	10	20	30
		4	15	30	50
		6	25	40	80
		10	40	60	100
3/4	20	6	25	60	100
		10	40	100	150
		15	60	150	200
		20	80	200	300
1	25	15	60	150	250
		20	80	200	400
		30	120	300	500
		40	150	400	600
1 1/2	40	30	120	300	500
		40	150	400	600
		60	240	600	1000
		100	400	800	1200
2	50	40	150	400	600
		60	240	600	1000
		100	400	800	1200
		200	800	1200	2000
3	80	200	800	1000	1500
		300	1000	2000	3000
		400	1500	3000	5000
		500	2000	4000	6000

Optional Low Flow Rates (Option ES)

Size		Full Scale Flow Range				
in	mm	liquid			gas (option I)	
		GPH	l/h	cc/m	SCFH	Nm ³ /h
1/2	15	4	15	200	40	1
		6	20	300	60	2
		10	40	400	100	3
		15	60	600	150	4
		20	80	1000	200	6
		30	120	2000	300	8
		40	150	3000	400	10
		60	240	4000		
		100	400	6000		

Series 8000 only (wafer)

Size		Full Scale Flow Range			
in	mm	liquid		gas (option I)	
		GPM	l/m	SCFM	Nm ³ /h
2 1/2	65	60	240	600	1000
		100	400	800	1200
		150	600	1000	1500
		200	800	1200	2000
4	100	300	1000	1500	50
		400	1500	3000	100
		600	2400	5000	150
		800	3000	6000	200
5	125	300	1000	1500	50
		400	1500	3000	100
		600	2400	5000	150
		800	3000	6000	200
6	150	600	2400	3000	100
		800	3000	5000	150
		1000	4000	8000	250
		2000	8000	15000	400
8	200	600	2400	5000	150
		1000	4000	8000	250
		2000	8000	15000	400
		3000	12000	20000	600

Pressure Drop Characteristics

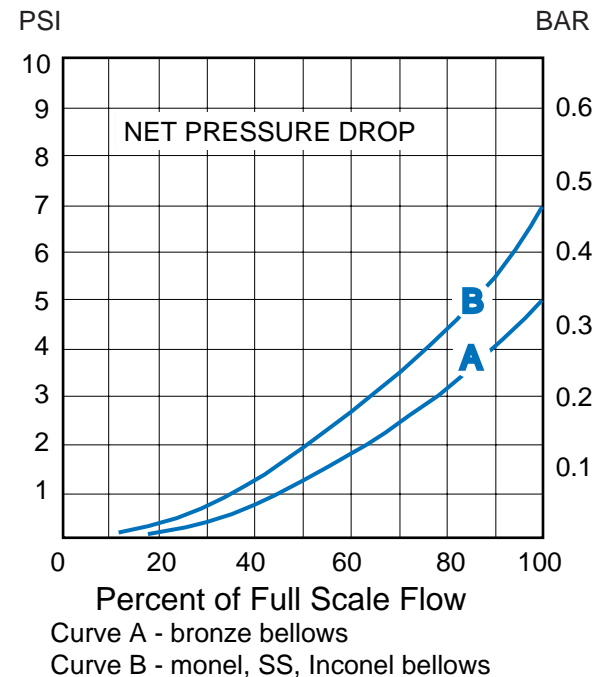

Selecting Meters for Liquid Service

The Flo-Gage can be used to meter flow rates of a wide variety of liquids including water, fuel oils (#2 through #6), lubricants, solvents and many chemical compounds.

For best accuracy, select a flow rate which will permit normal operation in the upper half of the meter scale.

To choose the proper meter, select pipe size and full scale flow rate from the chart of "Standard Flow Rates and Body Sizes".

Selecting Meters for Compressed Gas Service

The Flo-Gage can be used to measure flow rates of various gases such as **air, nitrogen, oxygen, carbon dioxide, hydrogen, propane, methane (natural gas), argon, helium, sulfur dioxide**, etc.

To insure satisfactory operation, pressure should be not less than **10 psig** at the meter inlet.

Minimum Flow Rates

The minimum flow rate which can be read is **approximately 15% of the full scale flow rate** for all meters. For best accuracy, select a flow rate which will permit normal operation in the upper half of the meter scale.

Services Not Recommended

Flo-Gages are **not recommended** for the following kinds of service:

- Resins, paints or monomers which can form solid deposits in the piping system.
- "Super-solvents" which attack most available elastomers.
- Sulfuric acid in any concentration.
- Foams which tend to have inconsistent densities.
- Toxic substances requiring hermetically sealed enclosures.
- Fluids with viscosity above 500 centipoise.
- Pumping systems using piston pumps which produce non-steady flow conditions.
- Gravity-fed systems having less head than the pressure loss across the meter at normal operating conditions.

RCM Industries, Inc

Dimensions

Nominal Size		Series 7000 A		Series 8000 A	
in	mm	in	mm	in	mm
1/4	08	5.20	132	n/a	n/a
1/2	15	5.20	132	6.62	168
3/4	20	5.95	151	7.06	179
1	25	6.07	154	7.25	184
1-1/2	40	6.39	162	7.81	198
2	50	6.80	172	8.00	203
2 1/2	65	n/a	n/a	8.54	217
3	80	7.48	190	8.87	225
4	100	n/a	n/a	9.95	252
5	125	n/a	n/a	10.36	263
6	150	n/a	n/a	11.05	280
8	200	n/a	n/a	12.30	311

Note: Dimensions are based on bronze meter.

Series 7000 Flo-Gage

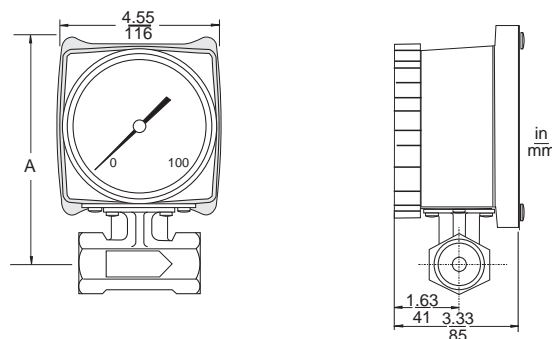

Series 8000 Flo-Gage

