

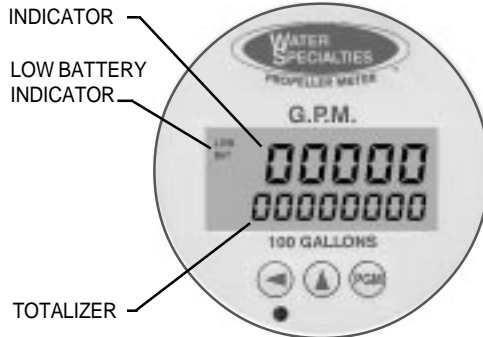

MODEL ML-04-D
 150 psi FLANGED TUBE METER
 SOLID STATE ELECTRONIC PROPELLER METER
 DIGITAL INDICATOR - TOTALIZER
 SIZES 2" thru 48"



TYPICAL
 DIGITAL INDICATOR-TOTALIZER



DESCRIPTION

MODEL ML-04-D FLANGED TUBE METERS are manufactured to the highest standards. Materials used on all meters and flow ranges for the low velocity meter meet, or exceed, AWWA standard C704. The flanged end tube design permits use in a wide range of applications with up to 150 psi working pressure. Flanged ends are 150 lb. AWWA class D flat face steel flanges. Fabricated steel meter tubes have straightening vanes and are protected internally and externally with 12-15 mils of NSF approved, fusion bonded epoxy resin.

INSTALLATION is made similar to placing a short length of flanged end pipe in the line. The meter can be installed vertically, horizontally or inclined on suction or discharge lines. The meter must have a full flow of liquid for proper accuracy. Fully opened gate valves, fittings or other obstructions that tend to set up flow disturbances should be a minimum of five pipe diameters upstream and one pipe diameter downstream from the meter. An optional kit of adapters with up to 100 feet of cable is available to locate the indicator-totalizer at remote locations.

PROPELLER is magnetically coupled with the electronic sensor through the sealed gearbox. This completely eliminates water entering the meter assembly, and eliminates all moving parts except for the propeller. The propeller is a conical shaped three bladed propeller, injection molded of thermoplastic material resistant to normal water corrosion and deformity due to high flow velocities.

BEARING in propeller is a water lubricated ceramic sleeve and spindle bearing system with a ceramic/stainless spindle. Dual ceramic thrust bearings, standard on all meters, handle flows in both forward and reverse directions. The bearing design promotes extended periods of maintenance free propeller operation.

DIGITAL INDICATOR-TOTALIZER has a non-volatile EEPROM memory to store totalizer count (updated every 60 minutes while running). The indicator dial can be furnished in GPM, CFS, MGD or any standard liquid measuring units with a choice of totalizer measuring units. The display is programmable to update from 0.5 to 5 seconds, and timeout from 1 to 9999 seconds.

INDICATOR (rate) FUNCTION is a five digit indicator with .35" tall numbers, programmable with 0 to 4 decimal point place with 0.0001 to 9999 rate scaling factor. The calculation method is 1/Tau. It has programmable smoothing of 0 to 99%. The rate zero time is 8 seconds.

TOTALIZER FUNCTION is an eight digit totalizer with .20" tall numbers, programmable with 0 to 4 decimal places, and a total scaling factor of 0.0001 to 9999. The totalizer can be reset from the front panel or disabled permanently.

O-RING SEALS are used at the meter head and all points where seals are required, making the sensor probe completely immune to any of the corrosive effects of atmospheric moisture or the liquids measured by the meter assembly.

SPECIFICATIONS

ACCURACY	Plus or minus 2% of actual flow within the range specified for each meter size.
PRESSURE RANGE	Up to 150 PSI maximum working pressure.
TEMPERATURE RANGE	140° F Maximum. Consult factory for special construction for higher temperatures.
MINIMUM FLOWS	As shown for each meter size and construction are required for accurate registration. See flow chart.
MAXIMUM FLOWS	As shown for each meter size and construction are rated for continuous operation. See flow chart.
INTERMITTENT FLOWS	As shown for each meter size are rated for 10% to 15% of the total time the meter is operating. Consult factory for High Velocity construction when intermittent flows are higher than shown on flow chart and/or when longer operating periods are required.
MATERIALS	Used in construction are chosen to minimize the corrosive effects of the liquids measured by the meter assembly. PROPELLER MAGNET - permanent ceramic type. PROPELLER BEARING - ceramic sleeve type. PROPELLER SPINDLE - ceramic coated stainless steel. PROPELLER - injection molded thermoplastic. GEARBOX - cast bronze. SEPARATOR - stainless steel. METER HEAD BOLTS - stainless steel (2" - 20"), plated steel (24" - 48"). METER HEAD - cast iron or fabricated steel, NSF approved fusion epoxy coated. METER TUBE - fabricated steel with straightening vanes and coated inside and out with 12-15 mils of NSF approved, fusion epoxy by the fluidized bed method.
OPTIONAL EQUIPMENT	Remote mounting kit with up to 100 feet of cable, totalizer extensions, digital transmitter, and a wide range of controls and instruments for indicating, totalizing and recording flow data for each meter. Special constructions and materials are available upon request.
ORDERING INFO	Must be specified by the customer and includes: Minimum & maximum flow ranges Temperature of meter environment Indicator scale & units Totalizer dial units Type of materials and construction Optional equipment desired

MODEL ML-04-D

150 psi FLANGED TUBE METER
 SOLID STATE ELECTRONIC PROPELLER METER
 DIGITAL INDICATOR - TOTALIZER
 SIZES 2" thru 48"

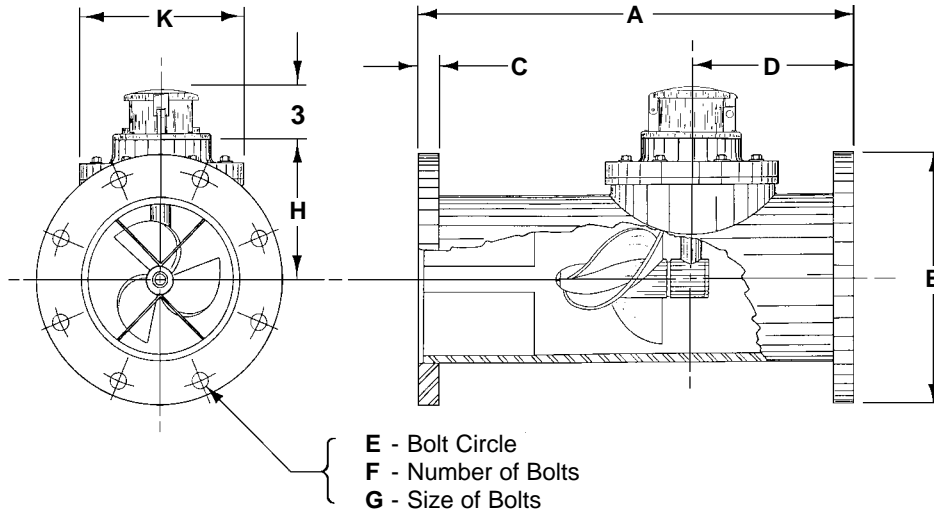

METER & PIPE SIZE	FLOW RANGES, GPM			DIMENSIONS (INCHES)									SHIPPING WEIGHT POUNDS
	*LOW VELOCITY CONSTRUCTION MIN. - MAX.	STANDARD CONSTRUCTION MIN. - MAX. - INT.	HIGH VELOCITY CONSTRUCTION MIN. - MAX.	A	B	C	D	E	F	G	H	K	
2	35-120	40-160-225	N/A	18¼	6	5/8	71/8	4¾	4	5/8	5¼	9	70
3	40-250	45-250-350	N/A	18	7½	5/8	7	6	4	5/8	5¼	9	70
4	50-500	55-500-700	200-700	18	9	5/8	7	7½	8	5/8	5¼	9	80
6	90-1200	120-1200-1500	300-1500	22	11	11/16	9	9½	8	¾	6¼	9	120
8	100-1500	150-1500-2000	400-2500	24	13½	11/16	9	11¾	8	¾	7¼	9	150
10	125-2000	180-2000-3000	500-3500	26	16	11/16	10	14¼	12	7/8	8½	11	200
12	150-2800	200-3000-3500	800-5000	28	19	13/16	10	17	12	7/8	9½	11	250
14	250-3750	300-4000-4500	1000-6000	42	21	15/16	12	18¾	12	1	10½	13½	350
16	350-4750	400-5000-6000	1200-7500	48	23½	1	12	21¼	16	1	11½	13½	570
18	450-5625	700-6000-7500	1500-9000	54	25	1 1/16	15	22¾	16	1 1/8	12½	13½	665
20	550-6875	850-8000-9000	2000-12000	60	27½	1 1/8	15	25	20	1 1/8	13½	13½	780
24	800-10000	1000-10000-13500	3000-15000	72	32	1 1/4	18	29½	20	1 1/4	17½	21	1250
30	1200-15000	1800-15000-21000	4000-25000	84	38¾	1 3/8	18	36	28	1 1/4	20½	21	2010
36	1500-20000	2000-20000-30000	5000-35000	96	46	1 5/8	20	42¾	32	1 1/2	23½	21	2840
42	2000-28000	3000-30000-40000	6000-50000	96	53	1 3/4	24	49¼	36	1 1/8	28	32	4300
48	2500-35000	5500-35000-50000	7000-60000	96	59½	1 7/8	24	56	44	1 5/8	31	32	4730

Standard construction will be supplied for all main line meters unless special flow range, materials, or construction are required.

* Low velocity (LV) construction has the same low and maximum flow rates as AWWA C704.



Visit our Website: www.mccrometer.com
 E-Mail: info@mccrometer.com

3255 WEST STETSON AVENUE • HEMET, CALIFORNIA 92545-7799 USA
 TEL: 909-652-6811 • FAX: 909-652-3078

Copyright © 2002 McCrometer. All printed material should not be changed or altered without permission of McCrometer. The published technical data and instructions are subject to change without notice. Contact your McCrometer representative for current technical data and instructions.