

### MODEL M1700

#### DESCRIPTION

Model M1700 Open Flowmeters are designed to measure the flow in canal outlets, discharge and inlet pipes, irrigation turnouts and other similar installations. The M1700 series meets or exceeds the American Water Works Association Standard C704-92. Constructed of stainless steel, the meter incorporates bronze mounting brackets that permit simple installation and removal. As with all McCrometer propeller flowmeters, standard features include a magnetically coupled drive, instantaneous flowrate indicator and straight reading, six-digit totalizer.

Impellers are manufactured of high-impact plastic, designed to retain both shape and accuracy over the life of the meter. Each impeller is individually calibrated at the factory to accommodate the use of standard McCrometer registers, and since no change gears are necessary, the M1700 can be field-serviced without the need for factory recalibration. Factory lubricated, stainless steel bearings

are used to support the impeller shaft. The sealed bearing design limits the entry of materials and fluids into the bearing chamber providing maximum bearing protection.

An instantaneous flowrate indicator is standard and available in gallons per minute, cubic feet per second, liters per second and other units. The register is driven by a flexible steel cable encased within a protective, self-lubricating vinyl liner. The die-cast aluminum register housing protects both the register and cable drive system from moisture while allowing clear reading of the flowrate indicator and totalizer.

#### INSTALLATION

The M1700 must be mounted on a headwall, standpipe or other suitable structure so that the propeller is located in the center of the discharge or inlet pipe. A straight run of full flowing pipe of at least five pipe diameters upstream of the flowmeter is required. Please specify the inside diameter of the pipe when ordering.



The McCrometer Propeller flowmeter comes with a standard instantaneous flowrate indicator and straight-reading totalizer. An optional electronic register is also available.  
*Typical face plates.*



#### APPLICATIONS

The McCrometer propeller meter is the most widely used flowmeter for municipal water and wastewater applications well as agricultural and turf irrigation measurements.

Typical applications include:

- Water and wastewater management
- Canal laterals
- Gravity turnouts from underground pipelines
- Sprinkler irrigation systems
- Golf course and park water management

# OPEN FLOWMETER MODEL M1700

## SPECIFICATIONS

### PERFORMANCE

**ACCURACY/REPEATABILITY:** ±2% of reading guaranteed throughout full range. ±1% over reduced range. Repeatability 0.25% or better.

**MAXIMUM TEMPERATURE:** (Standard Construction) 160°F constant.

### MATERIALS

**BEARING ASSEMBLY:** Impeller shaft is 316 stainless steel. Ball bearings are 440C stainless steel.

**DROP PIPE:** 304 stainless steel construction

**REGISTER:** An instantaneous flowrate indicator and six-digit straight-reading totalizer are standard. The register is hermetically sealed within a die cast aluminum case. This protective housing includes a

domed acrylic lens and hinged lens cover with locking hasp.

**IMPELLER:** Impellers are manufactured of high-impact plastic, retaining their shape and accuracy over the life of the meter.

### OPTIONS

- Register extensions
- All stainless steel bearing assembly
- Forward and reverse flow measurement
- "Over Run" bearing assembly for higher than normal flowrates
- Electronic propeller meter available in all sizes of this model
- A complete line of flow recording/control instrumentation
- Extra wall brackets

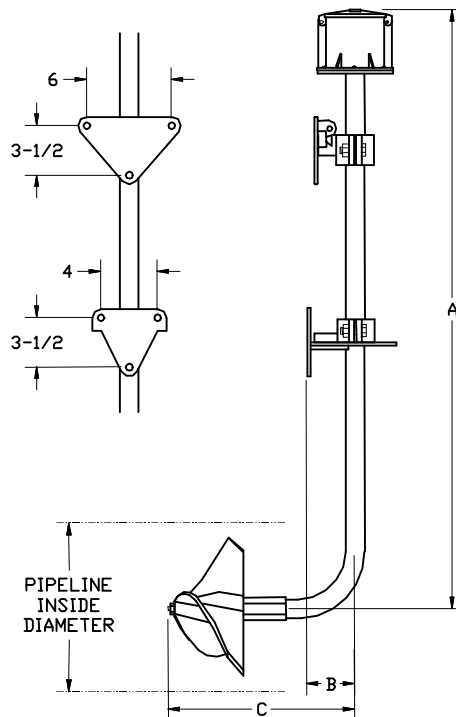

M1700	DIMENSIONS											
Meter Size (inches)	10	12	14	16	18	20	24	30	36	42	48	54
Maximum Flow U.S. GPM	1800	2500	3000	4000	5000	6000	8500	12500	17000	22000	30000	36000
Minimum Flow U.S. GPM	125	150	250	275	400	475	700	1200	1500	2200	2800	3500
Approx. Head Loss in Inches at Max. Flow	3.75	2.75	2.00	1.75	1.50	1.20	1.00	.52	.40	—	—	—
Approx. Shipping Weight Crated-lbs.	120	120	120	120	140	140	140	140	140	250	250	250
A * (in feet)	5	5	5	5	6	6	6	6	6	10	10	10
B Regular Brackets (inches)	2 13/16									4 3/8		
B Universal Brackets (inches)	3 15/16									—		
C (inches)	14 3/4	14 3/4	14 3/4	14 3/4	17	17	17	17	17	21 1/2	21 1/2	21 1/2

\* Standard lengths, optional lengths in 12" increments per customer order.

McCrometer reserves the right to change design or specification without notice.

FOR MORE INFORMATION CONTACT