

### MODEL M1104

#### DESCRIPTION

A lightweight, portable meter that provides both instantaneous flowrate indication and totalization. The compact design enables the operator to quickly and easily install the flow meter for instantaneous and accurate flow measurement. Designed for testing the flow rate of fire hydrants, the meter also provides totalization for use in determining collectible revenue for temporary hydrant deliveries. Other applications for the M1104 include industrial fire control, marine and sprinkler system testing.

The M1104 features a six-digit, straight-reading totalizer available in U.S. gallons, cubic feet and other standard units. The instantaneous flowrate indicator is standard and available in gallons per minute, cubic feet per second, liter per second and other units. The M1104 Fire Hydrant Flowmeter features a full 4-inch diameter meter tube allowing greater flow capacity. The meter tube is made of stainless steel for maximum strength and corrosion

protection. The short length design and convenient carrying handle facilitates installation, particularly in cramped spaces. The M1104 features standard 2½-inch fire hydrant threads; male threads on the outlet with a brass swivel coupling on the inlet side. The M1104 Fire Hydrant Flowmeter features a modular assembly for easy removal and maintenance of major components. The M1104 complies with the applicable provisions of AWWA Standard C704-92 and latest revisions for propeller flowmeters.

#### INSTALLATION

Standard installation is horizontal mount. If the meter is to be mounted in the vertical position, please advise the factory. A straight run of full pipe the length of five diameters ahead and one diameter behind the meter is the minimum normal recommended.



The McCrometer Propeller flowmeter comes with a standard instantaneous flowrate indicator and straight-reading totalizer. An optional electronic register is also available. Typical face plates.



© 1998 McCrometer

#### APPLICATIONS

- Hydrant rate testing
- Water usage billing
- Fire sprinkler testing
- Fire truck testing
- Industrial plant fire system testing
- Marine system testing

# FIRE HYDRANT METER MODEL M1104

## SPECIFICATIONS

### PERFORMANCE

**ACCURACY/REPEATABILITY:**  $\pm 2\%$  of reading guaranteed throughout full range.  $\pm 1\%$  over reduced range. Repeatability 0.25% or better.

**MAXIMUM TEMPERATURE:** (Standard Construction) 160°F constant.

**PRESSURE RATING:** 150 psi standard

### MATERIALS

**FLOW TUBE:** The flow tube is made of stainless steel. The impeller and bearing assembly are suspended in the center of the tube by 304 stainless steel ell.

Stator vanes located in the inlet of the flow tube generate steady, non-rotational water flow for greater accuracy. The swivel race and outlet threads are stainless steel for trouble-free hook up.

**IMPELLER:** Impellers are manufactured of high-impact plastic, retaining their shape and accuracy over the life of the meter. High temperature impeller is optional.

**BEARING ASSEMBLY:** Impeller shaft is 316 stainless steel. Ball bearings are 440C stainless steel.

**REGISTER:** An instantaneous flowrate indicator and six-digit straight-reading totalizer are standard. The register is hermetically sealed within a die cast aluminum case. This protective housing includes a domed acrylic lens and hinges cover with locking hasp.

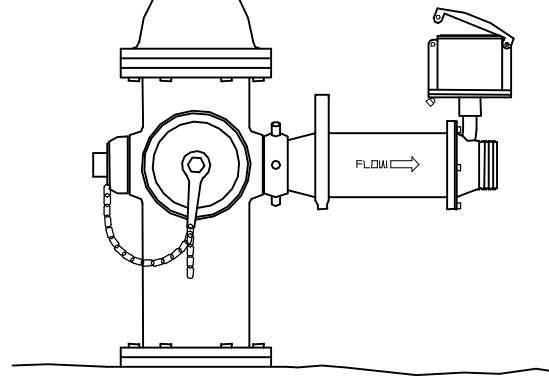
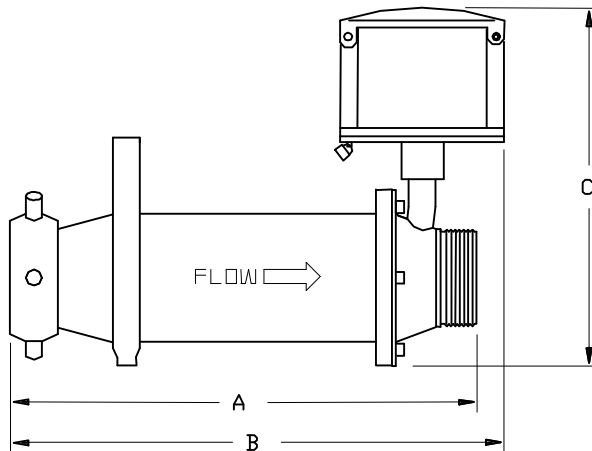

M1104	DIMENSIONS
Meter and Nominal Pipe Size (inches)	4"
Maximum Flow U.S. GPM	600
Minimum Flow U.S. GPM	50
Approx. Head Loss in inches at Max. Flow	60.00
Approx. Shipping Weight-lbs.	20
A (inches)	15
B (inches)	16
C (inches)	11.25

*McCrometer reserves the right to change design or specifications without notice.*

FOR MORE INFORMATION CONTACT:



3255 West Stetson Avenue  
 Hemet, CA 92545-7799 USA  
 909-652-6811 / FAX 909-652-3078  
 e-mail: info@mccrometer.com  
 Web Site: <http://www.mccrometer.com>