

# SC-FI Series

## Frequency to Current Signal Conditioner

### Features:

- Magnetic Pickup or Contact Closure Input
- Optically Isolated Input
- 10 kHz Maximum Input Frequency
- Standard, 2-Wire, 4-20 mA Output
- Two Year Warranty
- Loop Powered
- Various Mounting Styles
- LED Indicator

### Description:

The SC-FI is a two wire frequency to analog converter that converts a pulse rate input into a 4-20 mA output signal proportional to frequency or rate.

The input pulse rate is amplified and filtered by the input signal conditioning circuitry. Two forms of input signal conditioning are provided, one for magnetic pickups or contact closure inputs and the other is an isolated pulse input (depending on order code).

The amplified frequency signal is then converted to an analog signal using a precision frequency to analog converter.

The output stage derives its power from the output current loop. The output stage converts the analog input signal into the desired output range. Multi-turn potentiometers provide for the necessary trimming of span and zero.

### Specifications:

#### Operating Temperature

32° F (0°C) to 158°F (70°C)

#### High Level Pulse Input

Type: Opto-Isolated  
Input Impedance: 3.3 kΩ  
Logic 1: 4-30 VDC  
Logic 0: 0-1 VDC  
Frequency Range: 0-10 kHz  
Fault Protection: Reverse Polarity Protection  
Over Voltage Protection  
Isolation Voltage: 500 V  
Fast Transient Immunity: 500 V  
Maximum Rise Time: No Limit  
Maximum Fall Time: No Limit

#### Magnetic Pickup Input

Differential Input  
Input Impedance: 10 kΩ  
Frequency Response: 0-3500 Hz  
Trigger Sensitivity: 30 mV p-p  
Over Voltage Protection: ± 30 VDC

#### Contact Closure Input

Sensor Compatibility- Requires an isolated, contact closure  
Maximum Contact Voltage- 5 V  
Maximum Contact Current- 0.12 mA  
Nominal Pullup Resistance - 47 Kohm to 5 Vdc  
Frequency Range - 0-100 Hz



### Frequency to Current Conversion

Range Selection: DIP Switch Selectable

Available Ranges:

#### Standard

150 Hz, 300 Hz, 600 Hz, 1200 Hz,  
2500 Hz, 5000 Hz, 10,000 Hz

Factory Default: 1000 Hz

#### Contact Closure Option

30 Hz, 60 Hz, 120 Hz, 240 Hz,  
480 Hz, 960 Hz, 1920 Hz

Factory Default: 100 Hz

### Analog Output

Accuracy: ± 0.1% Span (@ 20° C)  
Output Type: Two Wire, Loop Powered  
Range: 4-20 mA  
Compliance Voltage: 10 to 40 VDC  
Loop Burden: < 10 VDC  
Trim Controls: Zero & Span, non-interacting  
Span (20 mA) Trim Range: 50% to 100% of full scale  
Linearity: < ±0.1% Span  
Output Voltage Effect: < ± 0.002% Span/Volt  
Temperature Effect: < 200 PPM/C°  
Reverse Polarity Protected  
Noise Content: < 0.2% Span  
Response Time: 0.1 second (1 sec. jumper selectable)  
Overcurrent Limiting: 35 mA  
Output Loop Indicator: LED illuminates when output loop is powered by proper polarity and blinks proportionally to the input frequency.

### Mounting Styles

DIN Rail Mount: Plastic enclosure with a snap fastener for fitting to DIN 46 277 and DIN EN 50 022 assembly rails.

NEMA 4X: 4.92" x 4.92" NEMA 4X Enclosure for wall mounting.

Explosion Proof: Aluminum enclosure for:  
Class I, Division 1, Groups B, C & D  
Class II, Division I, Groups E, F & G.

Listing: CE Compliant

**Dimensions**

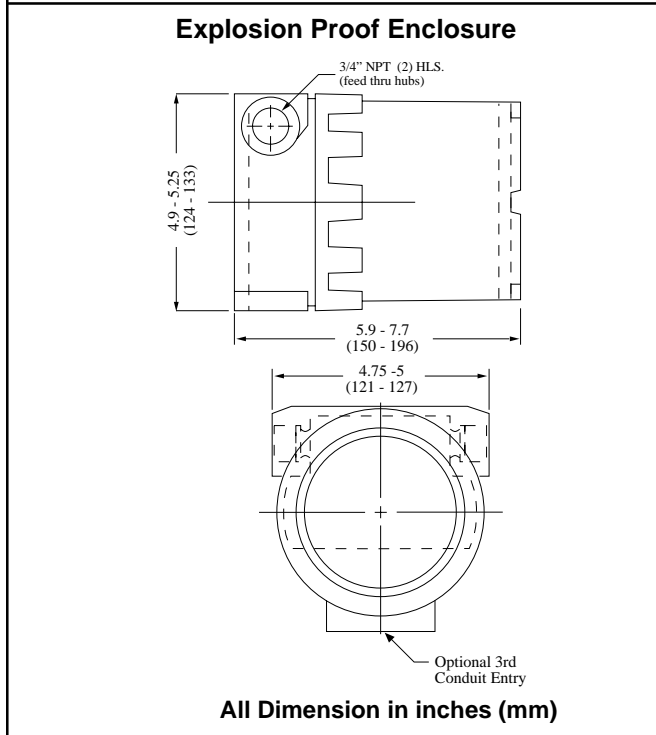
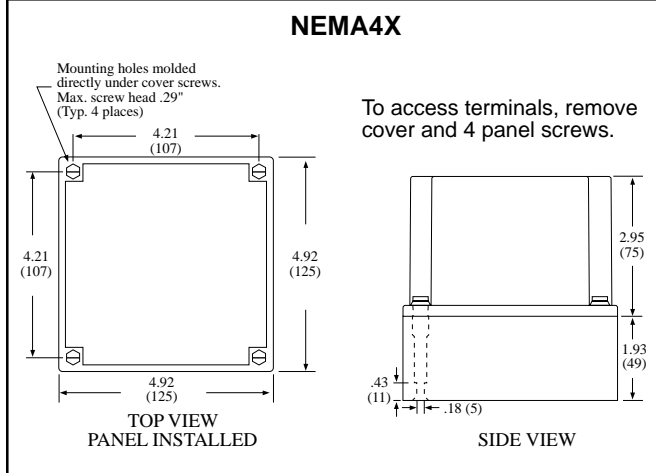
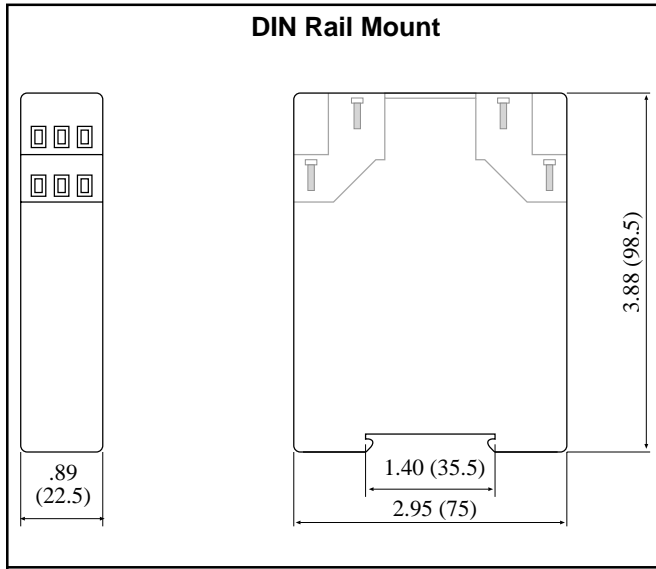

**Terminal Designations**

**Standard Termination**

- 1• Magnetic pickup
- 2• Magnetic pickup
- 3• Shield (common)
- 4• Opto-isolator In +
- 5• Opto-isolator In -
- 6• Shield (common)
- 7• Output +
- 8• Output -
- 9• Do Not Use

**SCFI-X-L (low count speed) Termination**

- 1• Do Not Use
- 2• Contact Input
- 3• Shield (common)
- 4• Opto-isolator In +
- 5• Opto-isolator In -
- 6• Shield (common)
- 7• Output +
- 8• Output -
- 9• Do Not Use

**Simplified Block Diagram**

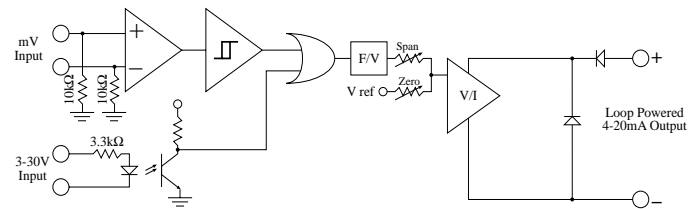

**Typical Application Magnetic Pickup Input**

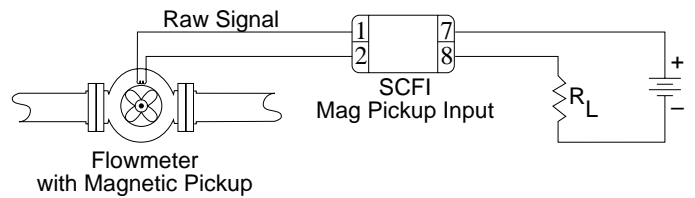

**Typical Application Contact Closure Input**

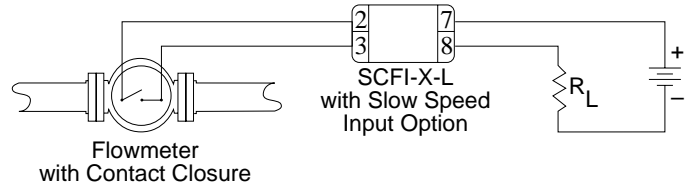

**Ordering Information**

<b>Example</b>	SC-FI	D	ET
<b>Series</b>	FI= Frequency to Current		
<b>Mounting:</b>	B= Nema 4X C= Explosion Proof D= DIN Rail		
<b>Options:</b>	ET= Extended Temp: -4° to 185°F (-20° to 85° C) L = Low Count Speed for Contact Closure Inputs T = Third 3/4" conduit entry for Explosion Proof Housing		

**Accessories:** (add to end of part number)  
DR-4= 4" DIN Rail