

# DPFC

## DIFFERENTIAL PRESSURE FLOW COMPUTER

### Features

- Compensates Steam, Gases and Liquids for Temperature and Pressure to Yield Corrected Volume, Mass and Heat Flow.
- Two Line by 20 Character Super Twist Back-Lit LCD Display
- Accepts Dual Differential Pressure (DP) Inputs
- Square Root Extraction of DP Inputs
- 16 Point Linearization
- Displays Compensated Rate and Total Flow
- Takes a Direct 100  $\Omega$  Platinum RTD
- Flow Rate, Temperature and Pressure Alarm
- 4-20 mA and Pulse Output Based on Compensated Flow
- 24 Volt Excitation Provided
- Front Panel NEMA 4X/IP 65 Rated



### Description

The KEP DPFC is a microprocessor based instrument designed to measure compensated flow in an industrial environment. Four analog inputs for temperature, pressure and dual differential pressure are provided to measure the parameters needed to calculate the actual compensated volume, mass or heat flow.

Special signal conditioning circuitry is included to allow direct connection of platinum resistance temperature detectors (RTD'S). Voltage inputs or current loops can be used for the above.

All instrument interface is with a 32 point screw terminal strip on the rear of the instrument.

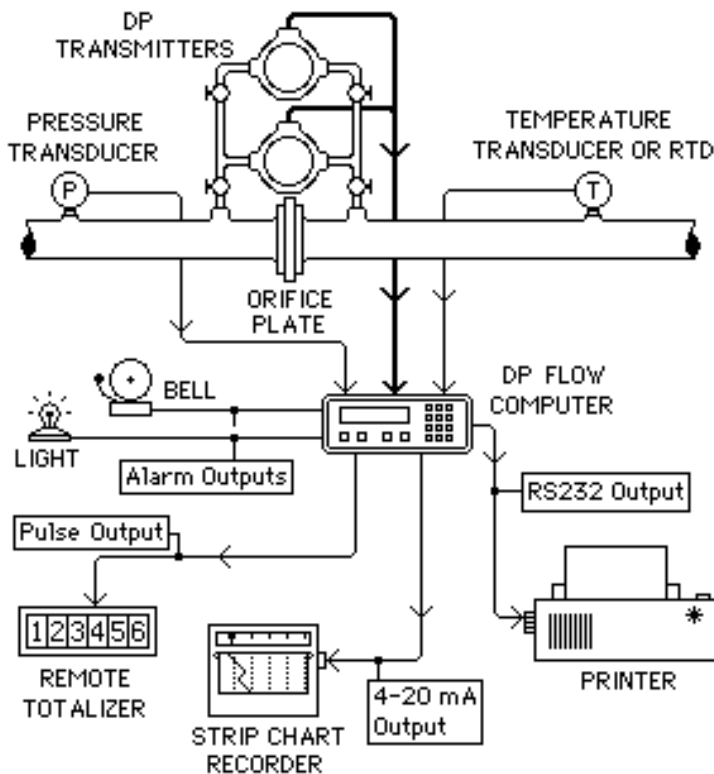

### DP Flow Computer Application

- § Pressure transducer sends 0-5V or 4-20 mA signal to Flow Computer.
- § 100 $\Omega$ , 4 wire, RTD direct hook-up to Flow Computer.
- § DP transmitters send signals to Flow Computer.
- § Flow Computer calculates flow and generates output signals.
- § 5 V pulse out to remote totalizer in supervisory area.
- § 4-20 mA out to strip chart recorder tracks trends.
- § RS232 out to printer for data logging.
- § Alarm relays activate bell and/or light as needed.

**General Specifications****OVERALL ACCURACY:** .25%**ENVIRONMENTAL:**

Operating Temperature: 32 to 122 F (0 to 50 C)

Storage Temperature: -10 to 160 F (-23 to 71 C)

Humidity: 0 to 90% Noncondensing

Front Bezel: NEMA 4X/IP 65

Case: ABS Plastic

**Listing:** CE Compliant**POWER:** (Internally Fused)115 / 230 VAC  $\pm 15\%$  (Switch Selectable)or 24VDC  $\pm 20\%$  or 12 VDC  $+20\%/-10\%$ 

Frequency: 50/60Hz.

Power Consumption: 10 Watts max

**Input Specifications:**

The following applies to all inputs. Inputs are referenced to signal ground. All ground terminals are connected internally.

NOTE: All inputs are single-ended with one leg grounded. The exception is the RTD input which is differential but is referenced to ground.

**CURRENT INPUTS:**Input Impedance: 100 $\Omega$ 

Range: 0-20mA, 4-20mA

Maximum sustained input voltage:

5 VDC (Fault Condition)

Resolution: .0244% FS

**VOLTAGE INPUTS:**Input Impedance: 115 k $\Omega$ 

Range: 0-5V, 0-10V

Resolution: .0244% FS

**TEMPERATURE INPUTS:**Compatible RTD type: 100 $\Omega$  Platinum $(\alpha = .00385; \text{DIN } 43-760 \text{ Calibration})$ 

Lead Wire Compensation: 4 Wire

Configuration: 2, 3 or 4 wire

Excitation Current: 2mA typical

Max Fault Current: 15mA

Max Volt on sense inputs: 50 VDC

Rejection of 50 or 60Hz signal: 40dB minimum (Automatically based on line frequency)

Raw Accuracy:  $\pm .5^\circ\text{C}$ **Output Specifications:****ANALOG OUTPUTS:**

Range: 4-20mA DC, sink only.

Compliance Voltage Range: 3 - 24 VDC

Load Type: Non Inductive

Accuracy:  $\pm .5\%$  FS

Update Rate: 1Hz

**PULSE OUTPUT:**This output is intended to drive a counter with a minimum input impedance of 1000 $\Omega$ . It is compatible with TTL and 5V CMOS logic inputs.

Output High Voltage

No load: 4.5 Volts min

4.0 mA source: 4.0 Volts min

Output Low Voltage

No Load: 0.2 Volts max

4.0 mA sink: 1.0 Volts max

Output waveform: Symmetric square wave above 1Hz 100msec pulse below 1Hz

Frequency Range: 0 to 50kHz

Max Slew Rate: 27 Volts/ $\mu\text{sec}$ 

Sustained Fault Voltage for no permanent damage: 7 Volts

**RELAY OUTPUTS:**

One relay is a flow alarm output and a second is for other alarm conditions. Each has the following electrical specifications:

Type: Dry Contact, Form C

Contact Rating: 10A @ 115/230VAC/28VDC

**AUXILIARY POWER OUTPUT:** (AC Powered units only)

Voltage: 24VDC regulated and filtered

Isolation: 230VAC max

The 24VDC Output is supplied with a resettable fuse.

Current: 0 to 100mA

Protection: Short Circuit Proof

**RS232 COMMUNICATIONS:**

Connector: 25 Pin Sub-D

Input Impedance: 3000 $\Omega$  to 7000 $\Omega$ 

Compliance Voltage:

Output: -25 to -5 (Mark);

5 to 25 (Space); Volts

Input: -25 to -3 (Mark);

3 to 25 (Space); Volts

Protection: Short circuit proof.

Protocol: 8 bits, 1 Stop bit

Parity: None (Not monitored)

Available Baud Rates: 300, 1200, or 9600

**DATA DISPLAY AND KEYPAD:**

Internal 2 line by 20 character dot matrix LCD display. Sealed, 16 key panel featuring numeric keys

0- 9, plus the following keys:

A Advance through menus

B Back up through menus

C Cancel current menu selection

D Decimal point key

ENT ..... General purpose enter or recall data key

CLR ..... Data clear key

**OPERATION:**

Through the 16 button, NEMA 4X/IP 65, front keypad, the operator enters all parameters necessary to configure the DPFC. No additional input cards or dipswitch settings are needed.

The operator selects the type of compensation desired for the medium (steam, ideal gas or liquid). For steam flow and heat measurement the 1967 ASME steam tables for saturated and superheated steam are stored in memory. For gases and liquids, the necessary factors are entered in by the operator.

Additionally, the following hardware parameters must be entered to configure the DPFC input signal types (from the temperature, pressure and differential pressure transmitters) along with their corresponding ranges or factors and alarm set points. Also the 4-20mA output, pulse output and optional serial port can be set up. If desired, the operator can lockout the unit from changes by entering a five digit lockout code.

The optional RS232 serial communications allows for timely printouts of flow results and/or parameters as well as parameter down load and up load for easy computer programming.

**SOFTWARE ACCESSORIES:**K1 Diskette:

A diskette program is available to assist in the computation of the K1 term. The K1 factor is used in Orifice/Pitot/Annubar calculations. The K1 factor is the calibration factor for the meter run. It is part of the Variables menu for flow input values (analog).

MASSCON Diskette:

The MASSCON diskette program facilitates the configuration and calibration of the flow computer. The program runs on PC compatibles and communicates through the RS232 port.

**TERMINAL BLOCK DESIGNATIONS:**

PIN	RTD	VOLTAGE IN	CURRENT IN	FUNCTION
1	RTD EXCITATION +	-----	-----	CHANNEL 1 TEMPERATURE
2	RTD SENSE +	-----	-----	
3	RTD SENSE -	-----	-----	
4	RTD EXCITATION -	-----	I IN +	
5	GROUND (SHIELD)	V IN - (GND)	I IN - (GND)	
6	-----	V IN +	-----	
7	RTD EXCITATION +	-----	-----	CHANNEL 2 PRESSURE or AUX. TEMP.
8	RTD SENSE +	-----	-----	
9	RTD SENSE -	-----	-----	
10	RTD EXCITATION -	-----	I IN +	
11	GROUND (SHIELD)	V IN - (GND)	I IN - (GND)	
12	-----	V IN +	-----	
13	-----	-----	I IN +	CHANNEL 3 FLOW (LOW) DP
14	GROUND (SHIELD)	V IN - (GND)	I IN - (GND)	
15	-----	V IN +	-----	
16	-----	-----	I IN +	CHANNEL 4 FLOW (HIGH) DP2
17	-----	V IN +	-----	
18	GROUND (SHIELD)	V IN - (GND)	I IN - (GND)	
19	ANALOG OUTPUT (SINK)			ANALOG OUT
20	PULSE OUTPUT			5V SCALED PULSE OUT
21	GROUND (SHIELD)			
22	N.O.			ALARM RELAY
23	N.C.			
24	COMMON			
25	N.O.			FLOW ALARM RELAY
26	N.C.			
27	COMMON			
28	115/230 VAC 50/60Hz			POWER (AC)
29	115/230 VAC 50/60Hz			
30	+24 VOLTS	24VDC OUT	+ VDC IN	POWER (DC)
31	24 VOLTS RETURN	(AC POWERED UNITS ONLY)	-DC (GND)	
32	CHASSIS GROUND			

**TYPICAL HOOKUP:**

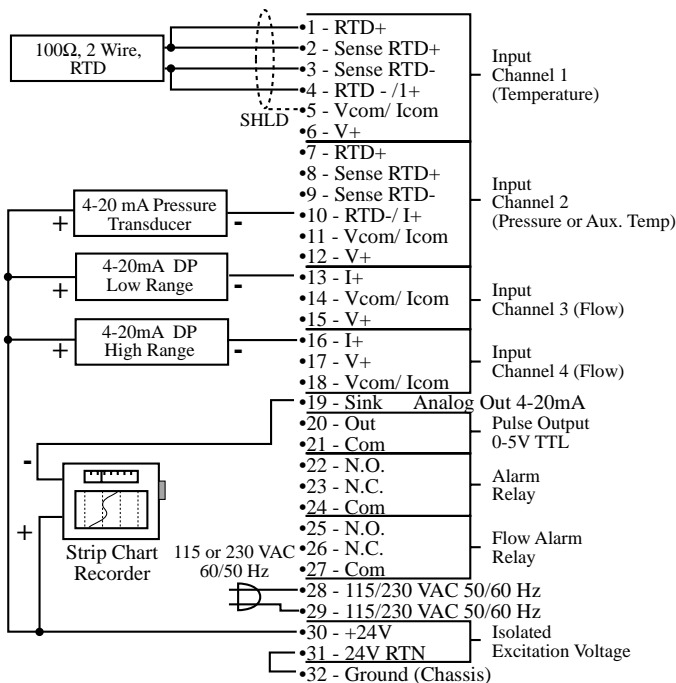

**Ordering Information**

**Example:** DPFC A 1

**Series:** DPFC

**Operating Voltage:**  
 A: 115 VAC ± 15% at 50/60Hz  
 B: 230 VAC ± 15% at 50/60Hz  
 C: 24 VDC ± 20%  
 D: 12 VDC -10, +20%

**Options:**  
 1: RS-232 Serial Interface  
 CSA: CSA Approved Unit (pending) ..... (consult factory)

**Accessories:**  
 NEMATROL 4X1 - NEMA 4X/IP 65 Enclosure for wall mounting accommodating 1 TROL Series unit.  
 NEMATROL 4X2 - NEMA 4X/IP 65 Enclosure for wall mounting accommodating 2 TROL Series unit.  
 FLEXCOVER #36120  
 XTROL7/4- Explosion proof housing  
 P1000 Printer (see Accessories)

**Dimensions:**

