

Features

APPLICATIONS: For use in the measurement of potable water for applications where flow is consistently moderate to high. Designed for applications where accuracy is an essential part of maintaining revenue. The Horizon horizontal turbine meter is built to maintain accuracy over extended periods of use.

CONFORMANCE TO STANDARDS: Horizon turbine meters have some of the widest flow ranges of any turbine meters on the market. All Horizon series turbine meters meet or exceed the latest performance and accuracy standards of AWWA C701. Two inch Horizon meters have FM Approval. Maximum continuous flow rates may be exceeded by as much as 25% for intermittent periods.

CONSTRUCTION: The Horizon consists of three basic parts; maincase; measuring insert; and register. Maincases are made of bronze. Measuring elements are thermoplastic with unique inlet and outlet straightening vanes.

To simplify maintenance, the Horizon is designed to allow quick, easy, in-line exchange of the measuring element without removing the maincase from the installation. Interchangeability of many parts within various sizes minimizes spare parts inventory and the Horizon comes standard with built-in strainer.

REGISTER: Permanently sealed register has a unique seal and heat-treated glass to eliminate dirt, moisture infiltration and lens fogging. An integral tamper-proof locking feature is provided to prevent tampering of the register and calibration vane. The totalizing register has a straight-reading odometer type display; 360° test circle with center sweep hand and a low flow (leak) detector. Standard gearing is used, making registers interchangeable by size.

All Hersey meter Models have electronic meter reading systems available for increased reading efficiency (see Meter Reading Systems.)

OPERATION: Water flows straight through the measuring element where it turns a rotor at a rate in direct proportion to the quantity of water flowing through the meter. The straight-through design allows high volumes to flow with a minimum of head loss. Retro Thrust® design extends the life of the meter by dividing wear between two points: during low flow the tungsten carbide bearing in the rotor floats against a stainless steel shaft; during high flow a second tungsten carbide bearing gently moves back against another stainless steel shaft. During medium flow, the rotor floats between both tungsten carbide bearings with sapphire bushings providing radial support for the rotor.

STRAINER & TEST PORT: Standard Built-in Strainer. Test port is optional with spool piece.

CONNECTIONS: ANSI Class 150 Flanges. 1-1/2" NPT pipe threads on optional test outlet.

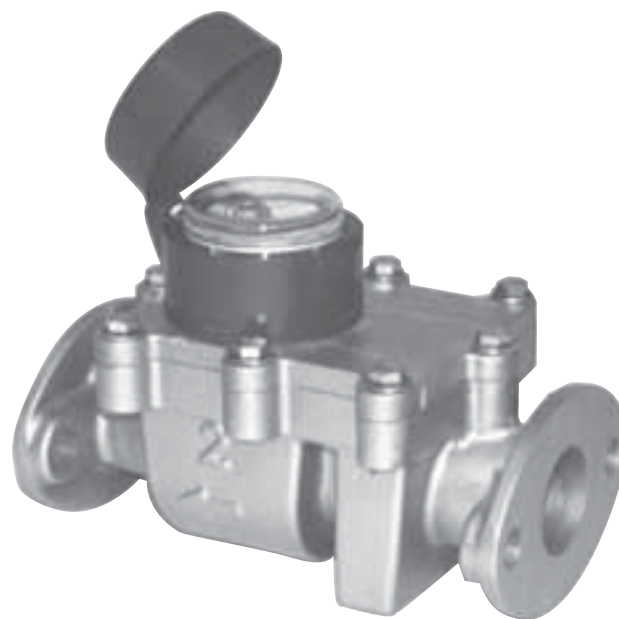

Horizon

Materials and Specifications

- **MODEL DESIGNATION** HORIZON
- **SIZES** 1-1/2", 2"
- **STANDARDS** Manufactured and tested to meet or exceed all applicable parts of ANSI/AWWA C701 class II Standard. 2" Horizon meters have FM Approval .
- **SERVICE** Cold water measurement.
- **NORMAL OPERATING FLOW RANGE** See Chart on page 3.2.
- **ACCURACY** See Chart on page 3.2.
- **PRESSURE LOSS** See Chart on page 3.2.
- **MAXIMUM WORKING PRESSURE** 175 PSI
- **TEMPERATURE RANGE** 33F to 100F water temperature
- **MEASURING ELEMENT** Stainless Steel and Thermoplastic
- **REGISTER TYPE** Straight reading, permanently sealed, magnetic drive with low flow indicator. Remote Readings units optional.
- **MATERIALS** Maincase – bronze UNS 84400; Casing bolts – Stainless steel ANSI B18; Rotor – Thermoplastic; Rotor radial bearing – Sapphire; Rotor thrust bearings – tungsten carbide; Rotor bearing pivots – Stainless steel ANSI B18; Magnet - rare earth/ceramic; Register box and lid – Thermoplastic or optional bronze; Standard strainer – Stainless steel; Spool piece with test outlet - bronze.
- **INSTALLATION** Horizontal or Vertical
- **METER CONNECTIONS** 1-1/2" – 2" ANSI Class 150
- **OPTIONS** AMR Reading Systems

Meter Registration

| Meter Size | Initial Dial* | Capacity | Initial Dial* | Capacity |
|------------|---------------|-------------|---------------|------------|
| 1-1/2" | 100 Gallons | 100 Million | 10 Cubic Feet | 10 Million |
| 2" | 100 Gallons | 100 Million | 10 Cubic Feet | 10 Million |

*Registration equal to one full revolution of the sweep hand.

Flow Characteristics

| Meter Size | Typical Low Flow (95% Minimum) | Typical Operating Range (100% ± 1.5%) | Maximum Continuous Operation | Maximum Intermittent Flow |
|------------|--------------------------------|---------------------------------------|------------------------------|---------------------------|
| 1-1/2" | 2 GPM | 4 to 120 GPM | 120 GPM | 160 GPM |
| 2" | 2-1/2 GPM | 4 to 160 GPM | 160 GPM | 200 GPM |

Performance*

1-1/2" HORIZON

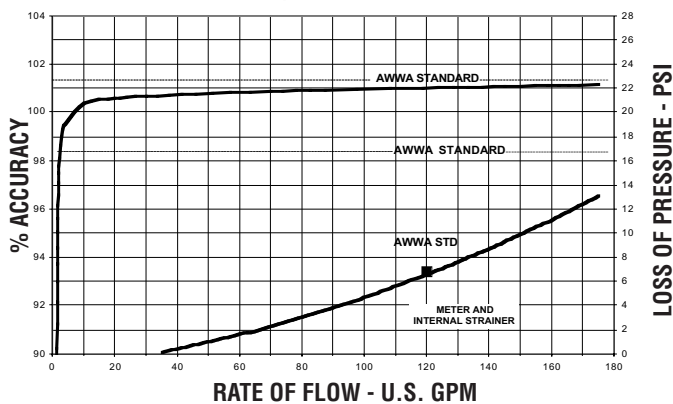

2" HORIZON

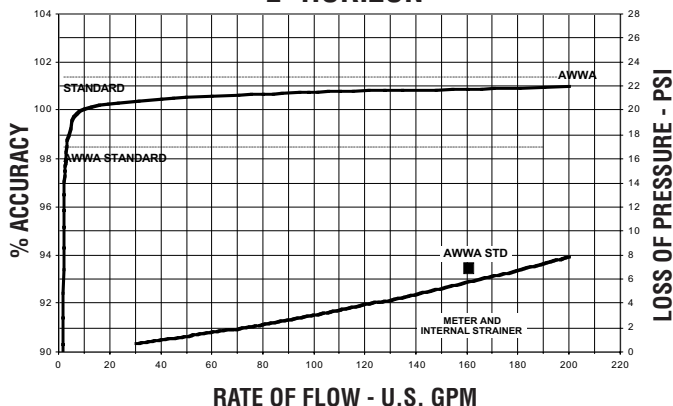

Dimensions & Weights

| Meter Size | 1-1/2" | 2" |
|---------------------------|--------|-------|
| Dimension | | |
| A Compact Length | 9 | 10 |
| AA Standard Length | 13 | 17 |
| B Height | 7-3/4 | 7-3/4 |
| C Centerline | 1-3/4 | 2-1/8 |
| D Holes | 3/4 | 3/4 |
| E Width | 6-1/8 | 6-1/8 |
| F Flange | 3/8 | 3/8 |
| Net Weight Compact - LBS | 22 | 23 |
| Net Weight Standard - LBS | 26.5 | 32 |

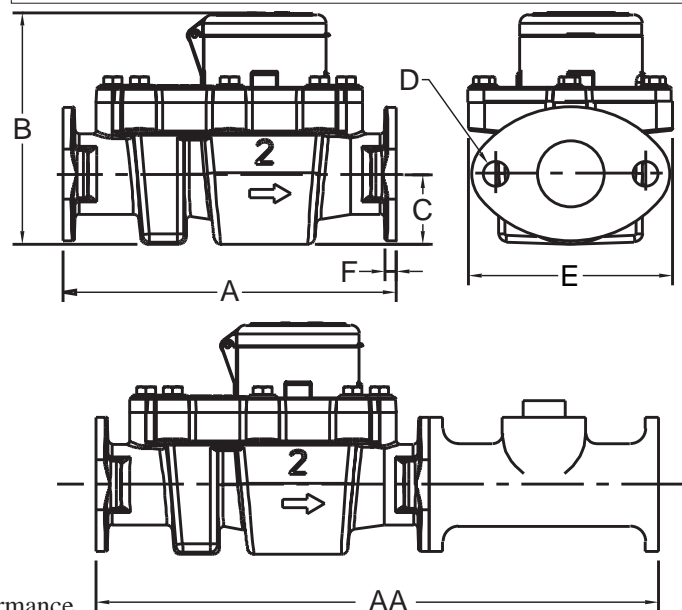

*Performance curves are typical only and not a guarantee of performance

Features

APPLICATIONS: For use in the measurement of potable water for applications where flow is consistently moderate to high. Designed for applications where accuracy is an essential part of maintaining revenue. The Horizon horizontal turbine meter is built to maintain accuracy over extended periods of use.

CONFORMANCE TO STANDARDS: Horizon turbine meters have some of the widest flow ranges of any turbine meters on the market. All Horizon series turbine meters meet or exceed the latest performance and accuracy standards of AWWA C701. Horizon meters in sizes 3"-10" are FM Approved. Maximum continuous flow rates may be exceeded by as much as 25% for intermittent periods.

CONSTRUCTION: The Horizon consists of three basic parts; maincase; measuring insert; and register. Maincases are made of bronze. Measuring elements are thermoplastic with unique inlet and outlet straightening vanes.

To simplify maintenance, the Horizon is designed to allow quick, easy, in-line exchange of the measuring element without removing the maincase from the installation. Interchangeability of many parts within various sizes minimizes spare parts inventory. Built-in test ports are standard for ease of field testing.

REGISTER: Permanently sealed register has a unique seal and heat-treated glass to eliminate dirt, moisture infiltration and lens fogging. An integral tamper-proof locking feature is provided to resist tampering with the register or calibration vane. The totalizing register has a straight-reading odometer type display, a 360° test circle with center sweep hand and a low flow (leak) detector. Standard gearing is used, making registers interchangeable by size.

All Hersey Meter Models have electronic meter reading systems available for increased reading efficiency (see Meter Reading Systems.)

OPERATION: Water flows straight through the measuring element where it turns a rotor at a rate in direct proportion to the quantity of water flowing through the meter. The straight-through design allows high volumes to flow with a minimum of head loss. Retro Thrust® design extends the life of the meter by dividing wear between two points: during low flow the tungsten carbide bearing in the rotor floats against a stainless steel shaft; during high flow a second tungsten carbide bearing gently moves back against another stainless steel shaft. During medium flow, the rotor floats between both tungsten carbide bearings with sapphire bushings providing radial support for the rotor.

STRAINER: A separate optional strainer is recommended to protect the measuring element.

CONNECTIONS: ANSI Class 150 Flanges on 3" through 10" sizes; 2" NPT pipe threads on test outlet.



Horizon

Materials and Specifications

- **MODEL DESIGNATION** HORIZON
- **SIZES** 3", 4", 6", 8", 10"
- **STANDARDS** Manufactured and tested to meet or exceed all applicable parts of ANSI/AWWA C701 class II Standard. 3"-10" Horizon meters are FM Approved
- **SERVICE** Cold water measurement with flow in one direction.
- **OPERATING FLOW RANGE** See Chart on page 3.4-3.5
- **ACCURACY** See Chart on page 3.4-3.5
- **PRESSURE LOSS** See Charts on pages 3.4-3.5
- **MAXIMUM WORKING PRESSURE** 175 PSI
- **TEMPERATURE RANGE** 33F to 100F water temperature
- **MEASURING ELEMENT** Stainless Steel and Thermoplastic
- **REGISTER TYPE** Straight reading, permanently sealed, magnetic drive with low flow indicator. Remote Readings units optional.
- **MATERIALS** Maincase – bronze UNSC84400; Casing bolts – Stainless steel ANSI B18; Rotor – Thermoplastic; Rotor radial bearing – Sapphire; Rotor thrust bearings – tungsten carbide; Rotor bearing pivots – Stainless steel ANSI B18; Magnet - rare earth/ceramic; Register box and lid – Thermoplastic or optional bronze.
- **INSTALLATION** Horizontal or Vertical
- **METER CONNECTIONS** 3" – 10" ANSI Class 150
- **OPTIONS** AMR Reading Systems

Horizontal Turbine Meters
 Sizes 3", 4", 6", 8", 10"

Meter Registration

| Meter Size | Initial Dial* | Capacity | Initial Dial* | Capacity |
|------------|---------------|-------------|----------------|-------------|
| 3" | 100 Gallons | 100 Million | 10 Cubic Feet | 10 Million |
| 4" | 100 Gallons | 100 Million | 10 Cubic Feet | 10 Million |
| 6" | 1000 Gallons | 1 Billion | 100 Cubic Feet | 100 Million |
| 8" | 1000 Gallons | 1 Billion | 100 Cubic Feet | 100 Million |
| 10" | 1000 Gallons | 1 Billion | 100 Cubic Feet | 100 Million |

*Registration equal to one full revolution of the sweep hand.

Flow Characteristics

| Meter Size | Typical Low Flow (95% Minimum) | Typical Operating Range (100% ± 1.5%) | Maximum Continuous Operation | Maximum Intermittent Flow |
|------------|-----------------------------------|------------------------------------------|---------------------------------|------------------------------|
| 3" | 3 GPM | 6 to 600 GPM | 600 GPM | 750 GPM |
| 4" | 4 GPM | 8 to 1000 GPM | 1000 GPM | 1250 GPM |
| 6" | 9 GPM | 15 to 2000 GPM | 2000 GPM | 2600 GPM |
| 8" | 18 GPM | 30 to 3500 GPM | 3500 GPM | 4400 GPM |
| 10" | 30 GPM | 40 to 5500 GPM | 5500 GPM | 7000 GPM |

Performance*

3" HORIZON

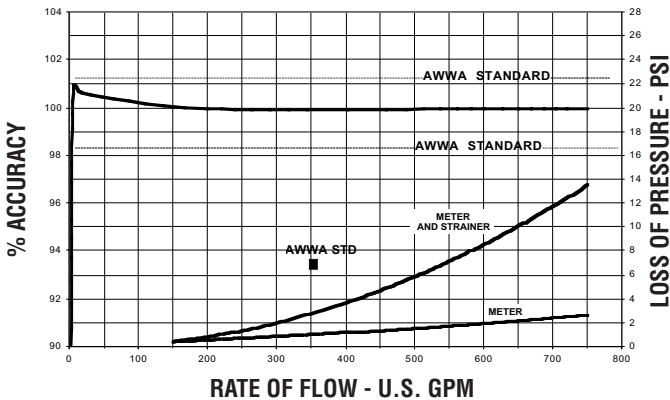

4" HORIZON

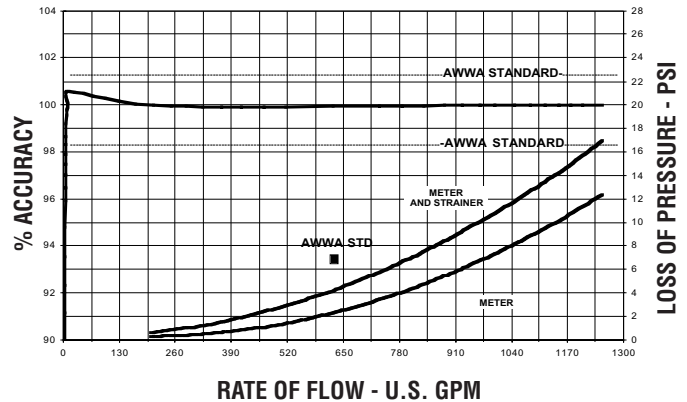

6" HORIZON

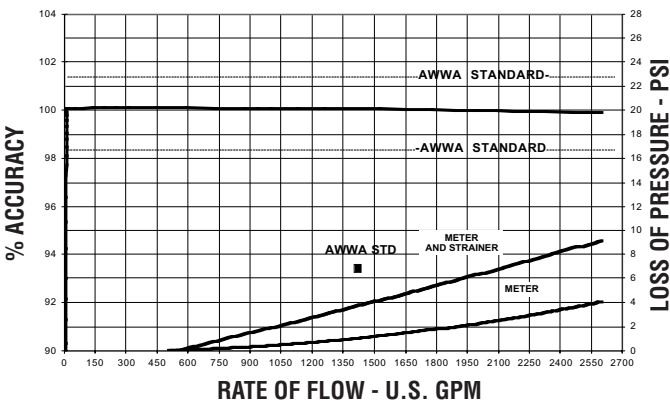

8" HORIZON

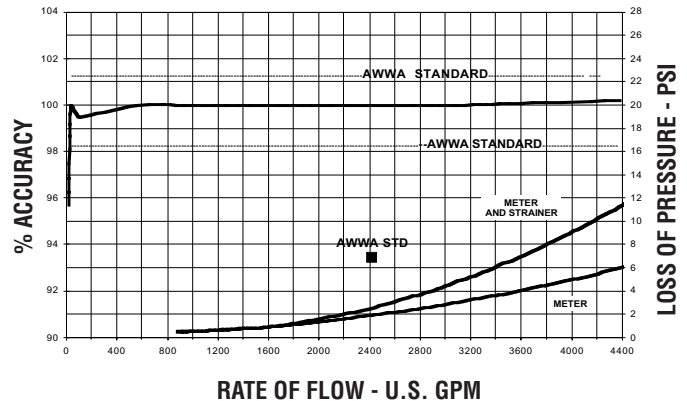

*Performance curves are typical only and not a guarantee of performance

Performance*

10" HORIZON

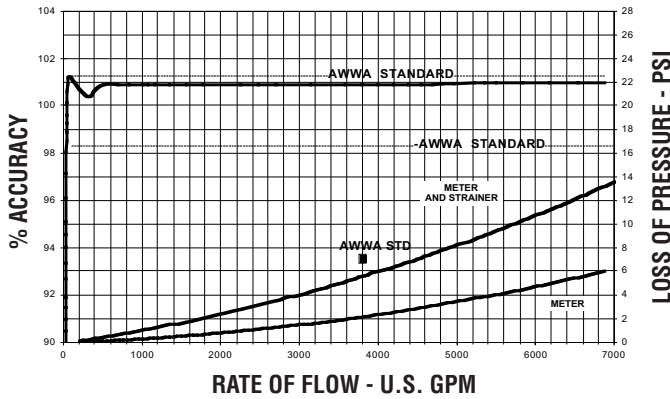

*Performance curves are typical only and not a guarantee of performance

Dimensions & Weights

| Meter Size | 3" | 4" | 6" | 8" | 10" |
|------------------|--------|---------|---------|---------|---------|
| Dimension | | | | | |
| A | 12" | 14" | 18" | 20" | 24" |
| AA | 18" | 21-1/2" | 27" | 30" | 36" |
| B | 10" | 10-3/4" | 13-1/2" | 15-1/2" | 18" |
| C | 3-3/4" | 4-1/2" | 5-1/2" | 6-3/4" | 8" |
| D | 3/4" | 3/4" | 7/8" | 7/8" | 1" |
| E | 7-1/2" | 9" | 11" | 13-1/2" | 16" |
| F | 3/4" | 7/8" | 7/8" | 1-1/8" | 1-3/16" |
| Net weight | 38 | 50 | 100 | 130 | 210 |

Note: Length AA is with standard strainer. Weights are in pounds and are approximate.

