

# INSTALLATION INSTRUCTIONS

## F-400

### SPECIFICATIONS

**Meter Body:** Acrylic, clear

**Floats:** #316 Stainless Steel or Hastelloy C-276

**Adapters:** Polypropylene with aluminum stress rings

**O-Rings:** Viton

**Scale:** Permanent Silkscreen

**Max. Pressure:** 150 PSIG / 10.3 BAR (see graph)

**Max. Temperature:** 150°F / 65.6°C (see graph)

**Accuracy:** ± 5% Full Scale

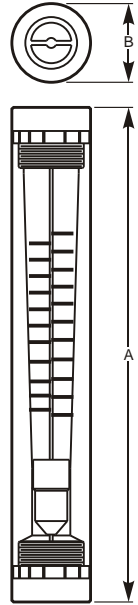

Model Number	A In. (mm)	B In. (mm)
F-40250N	8-3/16" (208.0mm)	1-1/4" (31.75mm)
F-40375N	8-3/16" (208.0mm)	1-1/4" (31.75mm)
F-40376N	8-3/16" (208.0mm)	1-1/4" (31.75mm)
F-40377N	8-3/16" (208.0mm)	1-1/4" (31.75mm)
F-40500N	8-3/16" (208.0mm)	1-1/4" (31.75mm)
F-40750N	11" (279.4mm)	1-3/4" (44.45mm)
F-41017N	11" (279.4mm)	1-3/4" (44.45mm)
F-41000N	11" (279.4mm)	1-3/4" (44.45mm)

### Your Blue-White® F-400 Series In-Line Flowmeter

- Your Blue-White® flowmeter was designed to be easy to install.
- Please read the Instruction Guideline on the next page before installing your flowmeter.
- This flowmeter is an instrument, special care should be taken when handling and installing.

### Inspection of the Flowmeter and Compatibility

- Carefully inspect the meter for any damage that may have occurred during shipping.
- Remove the plastic tubing that has been inserted during packaging for shipping reasons.
- Make sure your pressure, temperature, fluid and other requirements are compatible with the meter before installation.
- The maximum temperature capability decreases as the pressure increases. The max PSI decreases as the temperature increases. See the chart on the following page.
- Although the meter may be suitable for other chemicals, Blue-White® meters are tested with water and air only. If you are unsure of the meters compatibility with your chemical, please consult the factory.
- Blue-White® warrants the flowmeter for use with air and water only.



---

# Installation Guideline

Please use the following steps to guide you through the installation.

**Caution:** Follow these steps to avoid failure

**Danger:** Wear eye protection when installing or removing the flowmeter.

1. The flowmeter must be installed in an exact vertical plane to ensure accuracy.

2. Use Teflon® tape (or similar) on all pipe threads. Acrylic and other exotic plastics cannot tolerate PVC Glue and/or pipe dope. Even fumes can cause crazing. If you are installing your flowmeter to a glued pipe installation, install the flowmeter *after* all glued fittings are dried and lines are purged of all fumes. Never hold the meter with pliers or like tools. **DO NOT OVER-TIGHTEN!**

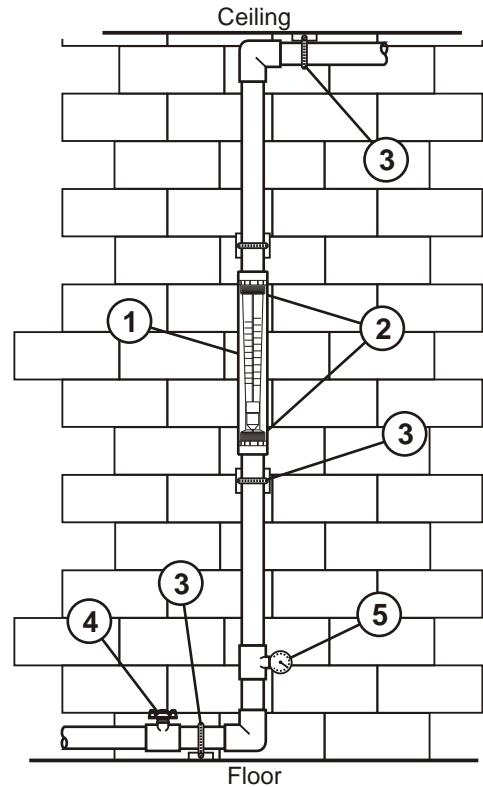

## F-400 Meter Installation

3. Wall, floor and ceiling mounts are to be carefully aligned and sturdy. Wall, floor and ceiling supports are recommended as needed. This is to maintain pipe alignment and to prevent vibration.

4. Valves - **Avoid a system that will impose a sudden burst of flow to the meter.** Such a burst will cause the float to impact the float stop with destructive force which may damage the flowmeter. Solenoid valves, or other quick opening valves cannot be used unless meter is protected against sudden bursts of flow. (If necessary a surge chamber should be installed. This will also be useful in high pressure start-up situations) The flowmeter is not warranted against this type of damage.

5. Maximum working pressure not to exceed recommended psi at fluid temperature (see Temperature Vs. Pressure chart).



---

## Temperature vs. Pressure

### Temperature

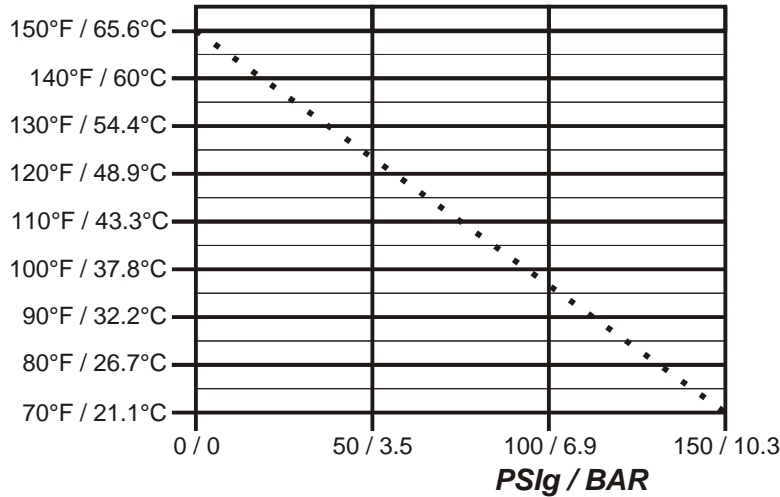

## Pressure and Temperature

Pressure and temperature limits are inversely proportional. At the maximum suggested pressure the temperature should approach 70°F / 21.1°C; at the maximum suggested temperature the pressure should approach zero psi. We cannot guarantee our flowmeters will not be damaged either at or below the suggested limits simply because of many factors which influence meter integrity; stress resulting from meter misalignment, damage due to excessive vibration and/or deterioration caused by contact with certain chemicals as well as direct sunlight. These situations and others tend to reduce the strength of the materials from which the meters are manufactured.

## Application Note

Flowmeters are tested and calibrated for water or air only.

Although meters may be suitable for other chemicals, Blue-White cannot guarantee their suitability. It is the responsibility of the user to determine the suitability of the flowmeter in their application.



**BLUE-WHITE INDUSTRIES**

F-400N 3/4" and 1" FPT  
1/4", 3/8" and 1/2" FPT

## Exploded View and Parts List

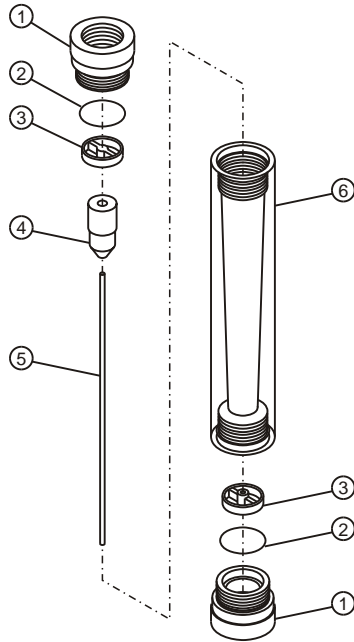

### Parts List 3/4" and 1" FPT

Item	Catalog Number	Description	Amount Required
1	F-4009	3/4" FPT Adapter F-400 PVC	2
1	F-4011	1" FPT Adapter F-400 PVC	2
2	F-4010K	O-ring, 127, Viton	2
3	F-4013PP	Wire holder, F-400, .75 - 1.0 PP	2
4	-	Float	1
5	F-4004	Guide Wire, F-400 .125 x 8.5 SS	1
6	-	F-400 Meterbody	1

### Parts List 1/4", 3/8" and 1/2" FPT

Item	Catalog Number	Description	Amount Required
1	F-4019	1/4" FPT Adapter PVC	2
1	76000-708	3/8" FPT Adapter PP	2
1	76000-707	1/2" FPT Adapter PP	2
2	90003-119	O-ring, 127, Viton	2
3	F-4005	Wire holder, F-400 1/4" PSF	2

Note: Shaded items are not sold separately

## Maintenance

The "Exploded View" drawing illustrates assembly of the F-400N series meter. If your flowmeter needs to be cleaned refer to this drawing when reassembling the unit. The tapered tube may be cleaned with a soft bottle brush. Use a MILD soap and water solution for cleaning purposes. Hard water deposits can be removed with a 5% acetic acid solution (vinegar). Note the floats "up" position.

## BLUE-WHITE INDUSTRIES LIMITED WARRANTY

**FLOWMETERS** are warranted to be free of defects in material and workmanship for up to 12 months from the date of factory shipment. Warranty coverage is limited to repair or replacement of the defective flowmeter only. Blue-White Industries does not assume responsibility for any other damage that may occur.

This warranty does not cover damage to the flowmeter that results from misuse or alterations, nor damage that occurs as a result of: meter misalignment, improper installation, over tightening, use of non-recommended chemicals, use of non-recommended adhesives or pipe dopes, excessive heat or pressure, or allowing the meter to support the weight of related piping. Flowmeters are tested and calibrated with water and air only. Although meters may be suitable for other chemicals, Blue-White cannot guarantee their suitability.

Flowmeters are repaired at the factory only. Call or write the factory to receive a Return Authorization Number, carefully pack the flowmeter to be returned, including a brief description of the problem. Note the RA number on the outside of the carton.

Prepay all shipping costs. The factory does not accept COD Shipments. Damage that occurs during shipping is the responsibility of the sender.

## BLUE-WHITE INDUSTRIES



**BLUE-WHITE INDUSTRIES**