

TS-150
Rev. 0-02-03-05

MP Oscillating Piston Flowmeter:
12.7 mm (1/2" Type MP)
25.4 mm (1" Type MP)
50.8 mm (2" Type MP)
76.2 mm (3" Type MP)

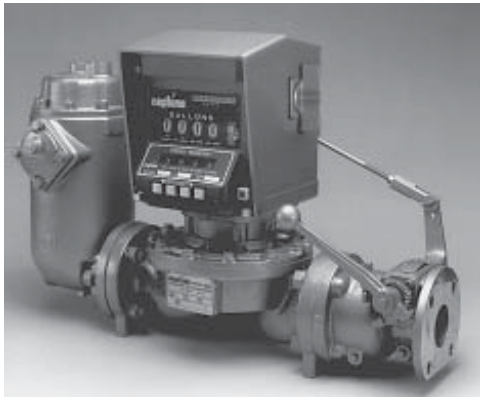

neptune[®] TYPE MP OSCILLATING PISTON FLOWMETER



**2 " Type MP with 800 Series Register,
Auto-Stop Valve and Air Release/Strainer**

- * **Flow Rates of 3.8 to 1,140 Litres/Min.
(1 to 300 gpm)**
- * **Accuracy of $\pm 0.5\%$ of Rate**
- * **$\pm 0.1\%$ Repeatability**
- * **Magnetically Coupled Output Shaft**
- * **Proven Reliable Oscillating Piston Design**
- * **Minimal Maintenance**
- * **Compact Design**
- * **Insensitive to Moderate Viscosity Changes**

SPECIFICATIONS

GENERAL

The Type MP Oscillating Piston Flowmeter provides high accuracy industrial liquids flow measurement. Actaris Neptune's MP Series of flowmeters have proven reliable through years of measuring over 400 common industrial liquids. Liquids in chemical processing, food plants, paints & coatings, pulp & paper plants, oils, cosmetics, pharmaceuticals, pesticides and additives industries are measured by MP Series flowmeters. Close tolerance machining combined with a minimum number of moving parts makes the MP insensitive to moderate changes in liquid viscosities.

The MP exhibits a typical accuracy of $\pm 0.5\%$ over a 10:1 turndown (from 100% to 10% of maximum rated flow) with repeatability of $\pm 0.1\%$. The accuracy may be improved in applications with more viscous products or with fixed flow rates.

Only minimal maintenance is needed to maintain the high level of MP flowmeter performance. The magnetic drive eliminates stuffing box leaks. The small number of moving parts results in less repair and downtime. The fluid is sealed from the environment by the use of a magnetically coupled output drive. The oscillating piston is one of the few moving elements of the meter and can be replaced without recalibration in only minutes. The externally mounted gear train is easily accessible.

PHYSICAL CONSTRUCTION

Casing and cover are available in 316 stainless steel, bronze, aluminum and iron. The oscillating piston is made of a molded polymer material that is optimized for the specific application. High temperature pistons are available upon request. The "O"-Ring seal material is Teflon[®] encapsulated silicone and Buna-N.

INDICATOR/OUTPUT

The Type MP can be specified with a variety of registers (e.g., mechanical or electronic) and pulse transmitters. Output functions include totalization, mechanically or electronically controlled batching and rate of flow monitoring.

ELECTRICAL CHARACTERISTICS

When used with a pulse transmitter (digital or analog), the Type MP can be used for remote electronic registration, batch control or chart recording. The Type MP flowmeter and electric auto-stop switch combination provide remote actuation of pumps, valves, and accessories.

ASSOCIATED INSTRUMENTS

The Type MP is available with a complete line of register options, local or remote totalization, pulse transmitters (with and without registers), electric or mechanical batch controllers/auto-stop valves and rate of flow transmitter with indicator.

ALARMS

A third party annunciator or other compatible instruments may be interfaced to the MP's measured flow rate through digital or analog transmitters to indicate deviation from set-points.

MECHANICAL AUTO-STOP VALVE OPTION

The mechanical auto-stop valve provides completely mechanical controlled batching. No outside power sources are required. Auto-Stop valves allow the operator to set the register for the desired quantity. The flow will shut off automatically at the exact volume desired. Auto-Stop valves are easy to maintain, reliable and handle a wide range of products. Controlled valve closing, available with the two-stage auto-stop valve, reduces the potential for hydraulic shock on both the dispensing lines and the flowmeter itself.

AIR RELEASE & STRAINER OPTION

The air release and strainer prevent air and foreign particles from entering the flowmeter, which may cause damage to the meter in addition to registration errors. In the air release, a float-actuated valve releases trapped air and vapor.

FLOWMETER OPERATING SPECIFICATIONS

CATEGORY		Type MP Flowmeter	
METER	Type of Measuring Element	Oscillating Piston	
	End Connections	1/2": External (male) NPT or ANSI Flange 1", 2", and 3": ANSI Flange	
	Temperature Rating (T Max)	121°C (250°F)*	
	Pressure Ratings (P Max)	316 Stainless Steel	19 bar @ 121°C (275 psi @ 250°F)
		Iron	10.34 bar @ 121°C (150 psi @ 250°F)
		Bronze	10.34 bar @ 121°C (150 psi @ 250°F)
	Flow Range (Q Max)	1/2"	3.8 - 38 lpm (1-10 gpm)
		1"	26.6 - 266 lpm (7 - 70 gpm)
		2"	57 - 570 lpm (15 - 150 gpm)
		3"	14 - 1140 lpm (30 - 300 gpm)
	Totalized Units (min)	1/2"	1 Litre, 1/10 US Gallons
		1", 2" and 3"	1, 10, 100 Litre 10, 100 Lb 10, 100 Kg 1/10, 1 or 10 US Gallons
	Enclosure Class	Totally mechanical. If interfaced with a pulse transmitter, the rating of the device applies.	
	Power Supply	None, unless fitted with a pulse transmitter, then the rating of the installed device applies.	
Main Body Material	1/2"	316 Stainless Steel	
	1", 2"	Iron, Bronze, or 316 Stainless Steel	
	3"	Bronze or 316 Stainless Steel	
Main Body Cover Material	1", 2", 3"	Bronze	
	1/2", 1", 2", 3"	316 Stainless Steel	
Piston Material	LCP for Bronze and Iron PPS for 316 Stainless Steel (ETFE is optional)		
Shaft Material	316 Stainless Steel (internal magnetic drive assembly)		
Packing and Gasket Material	Teflon® encapsulated Silicone		
Type of Coupling	Magnetic Drive		

*Note: ETFE Piston material is rated for 180°F maximum.

CATEGORY		Type MP Flowmeter
COUNTER	Register Type a. Mechanical, on Flowmeter b. Electronic, Remote c. Electronic Register, on flowmeter	SM Register: Non-Reset Totalizer (only), Magnetic Drive 600 Series: Reset and Totalizer 800 Series: Reset and Totalizer (all) 831/841: Reset and Totalizer 832/842: Preset (1- or 2- stage closure) 833/843: Ticket Print 834/844: Both Preset and Ticket Print Batch control: BATCHMATE 1500™ with LED readout of flow total, grand total, flow rate, 1- or 2- stage batching and input pulse scaling; requires digital pulse transmitter. Pulsemate: Resettable and Non-resettable (cumulative)
	Totalizer	Pulsemate: Dual Totalizer (DP) – 5 digit resettable, 8 digit Non-resettable Rate and Total (RP) – 8 digit resettable Rate AlarmTotal (RA) – 8 digit resettable 600 Series: 8-digit non-resettable 800 Series: 8-digit non-resettable BATCHMATE 1500™: 8-digit non-resettable and grand total (may be programmed with lock-out on reset)
	Capacity	Pulsemate: 99,999,999 - 1 gal/liters resolution 600 Series: 99,999,999 800 Series: 99,999,999 BATCHMATE 1500™: 99,999,999 (electronically programmable to any combination)
	Reset	600 Series: 5-digit resettable 800 Series: 5-digit resettable BATCHMATE 1500™: 8-digit resettable
	Auto-Stop	Model 832/842/834/844: Mechanical (1- or 2- stage closure) BATCHMATE 1500™: Electronic (1- or 2- stage closure)
	OPTIONS	Alternate Units of Measure
Shut-Off Valve Note: Valve maximum pressure is 150 psi for all metallurgies		1- or 2- stage mechanical shut-off valves in the following metallurgies: 1" or 2" Bronze, Iron, 316 Stainless Steel 3" Bronze For electronic batch control with the BATCHMATE 1500™, a non-Actaris Neptune solenoid valve may be incorporated into the system.
Switch a. Single Stage b. Double Stage		Micro Switch Models: 23B 23A
Transmitter Type Note: Consult sales office for adapters		V/R 10:1 Contact Closure V/R 100:1 Hall Effect PE 500/505 Optical PES 550/555 Optical With Scaler
Transmitter		Output 10 or 100 pulses per revolution PES Model scalable from 0.0001 to 1.9999 Pulsemate: Scalable pulse output, standard Field adjustable 4-20 mA analog output, optional
Air Eliminator		Available for 1" and 2" Type MP Flowmeters
Strainer Size and Mesh		Incorporated in air eliminator unit; 40 mesh standard
Manufacturer		Actaris Neptune Liquid Measurement Division

ACCURACY AND PRESSURE LOSS DATA

TYPICAL ACCURACY CURVES
Percent Registration -vs.- Flow Rate

PRESSURE LOSS CURVES
PSI -vs.- Flow Rate

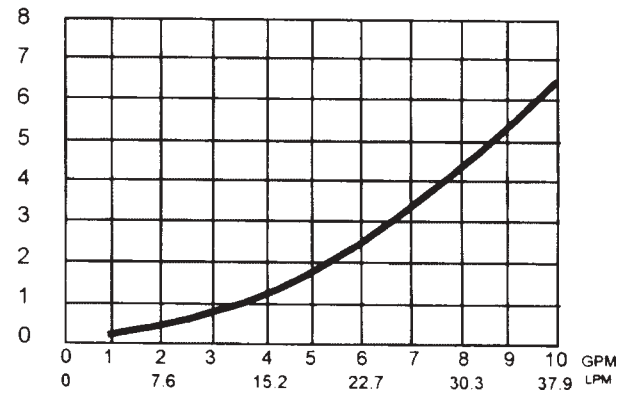
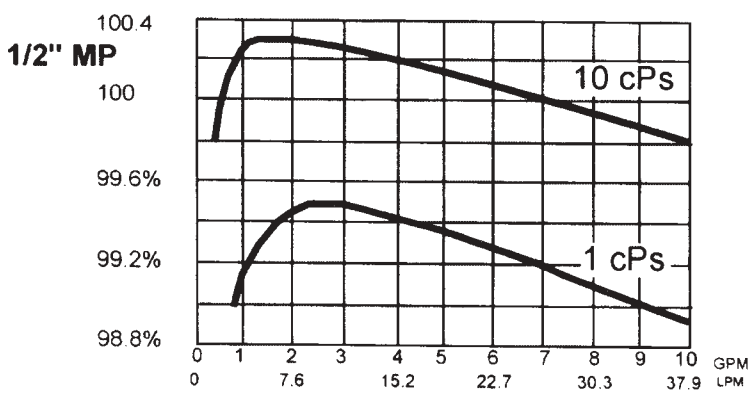
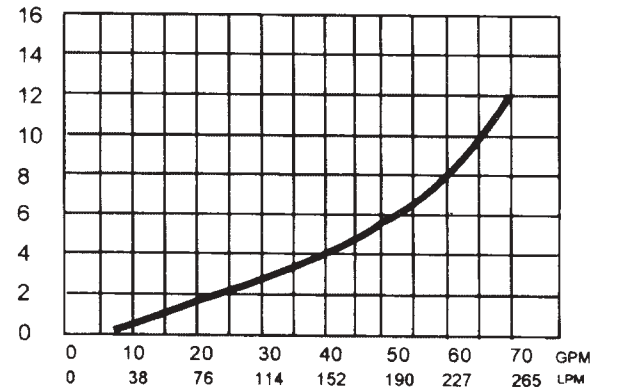
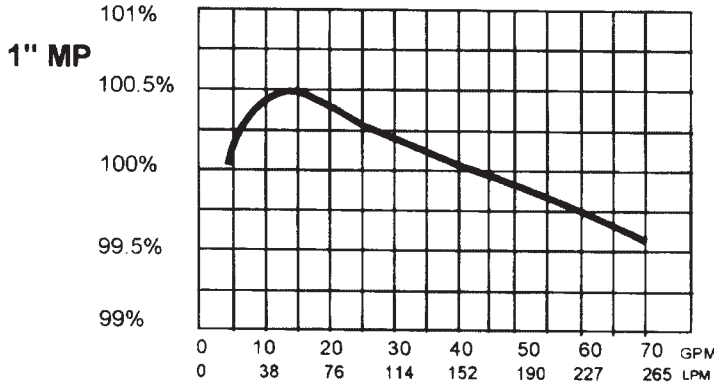
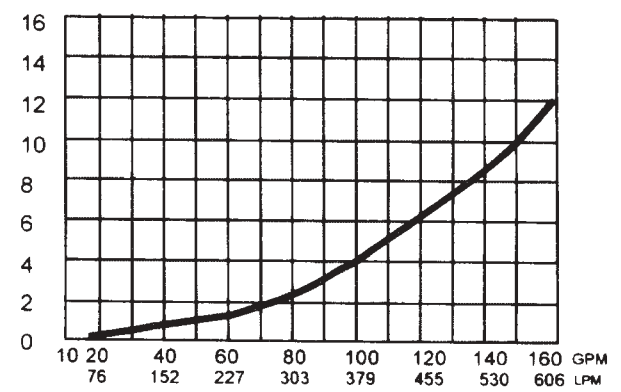
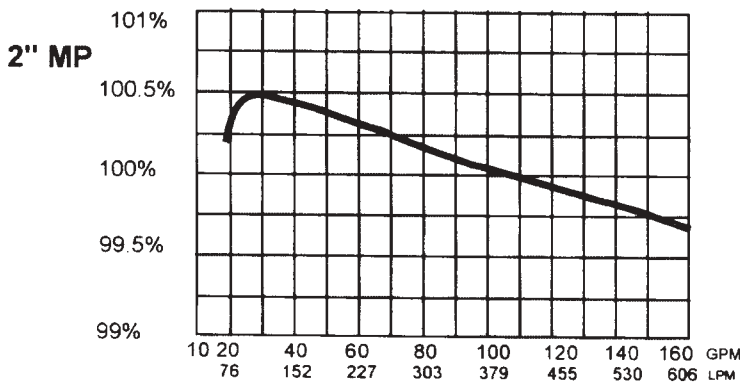
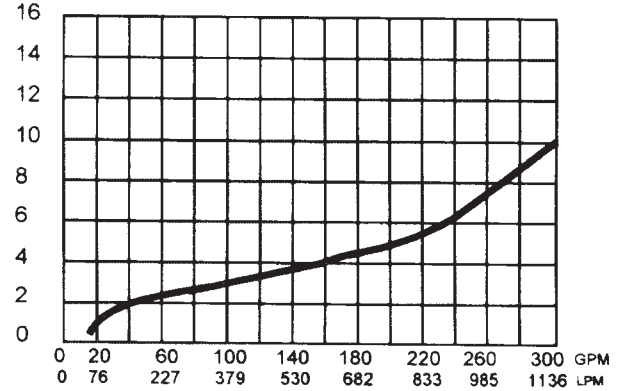
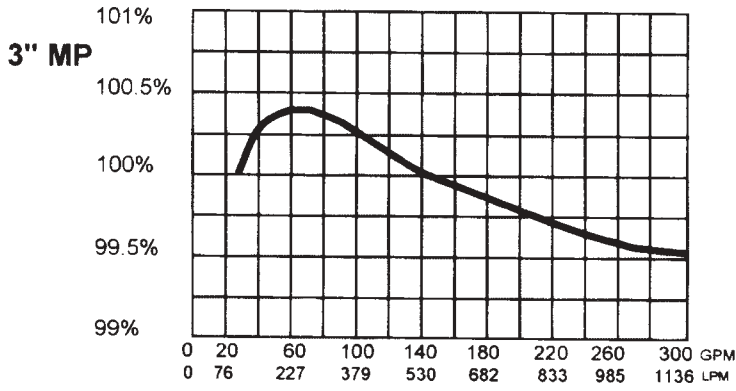

**DIMENSIONAL DATA
SIZE 1/2"**

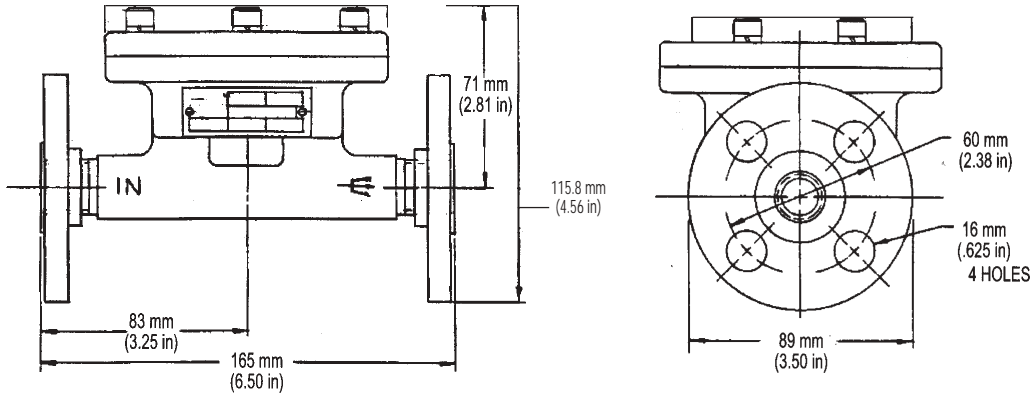

1/2" Type MP

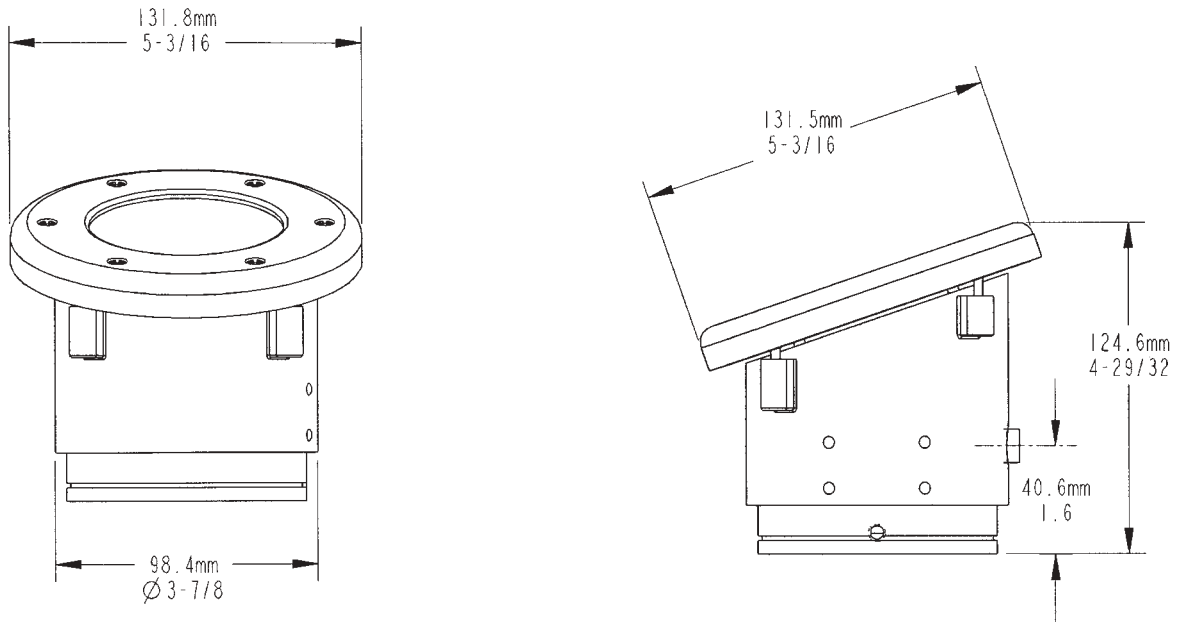

Pulsmate

DIMENSIONAL DATA SIZE 1"

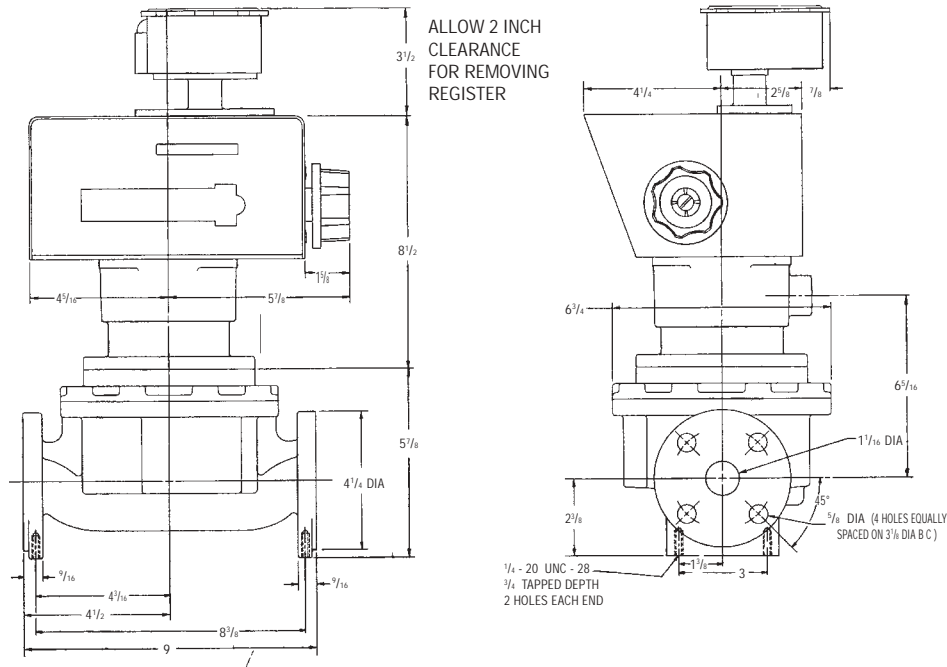

1" Type MP with 600 Series Register and Model 45 Pulse Transmitter

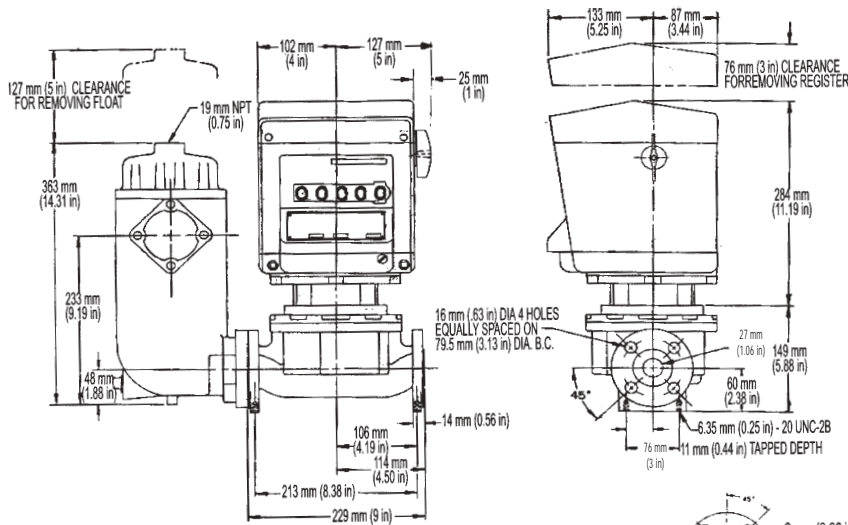

**1" Type MP
with 800 Series Register
and Air Release/Strainer**

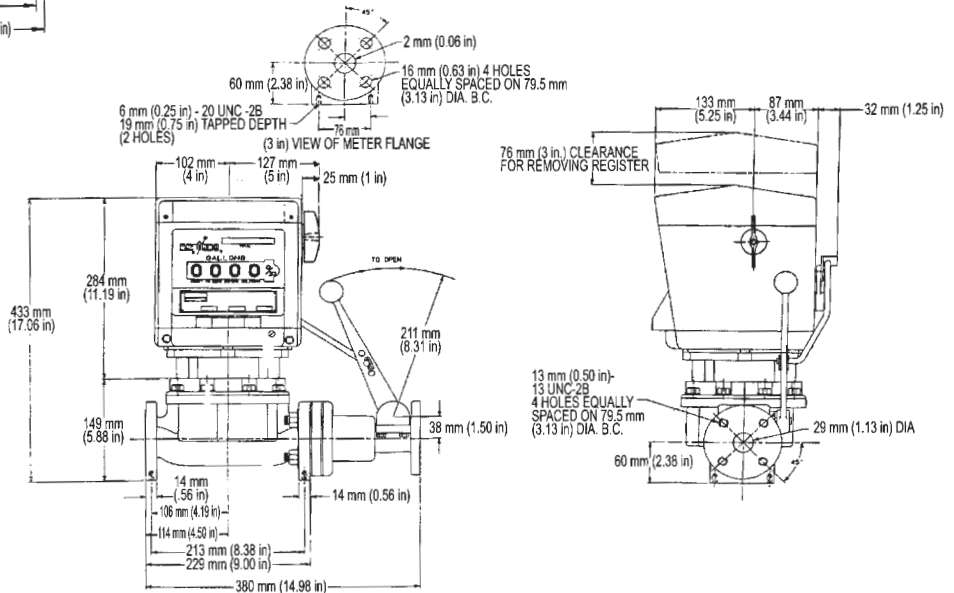

**1" Type MP
with 800 Series Register
and Auto-Stop Valve**

DIMENSIONAL DATA SIZE 2"

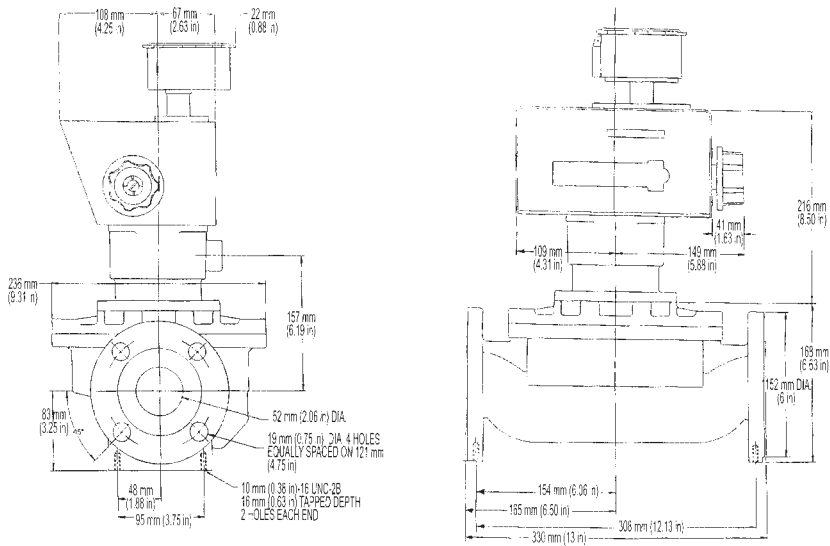

2" Type MP with 600 Series Register and Model 45 Pulse Transmitter

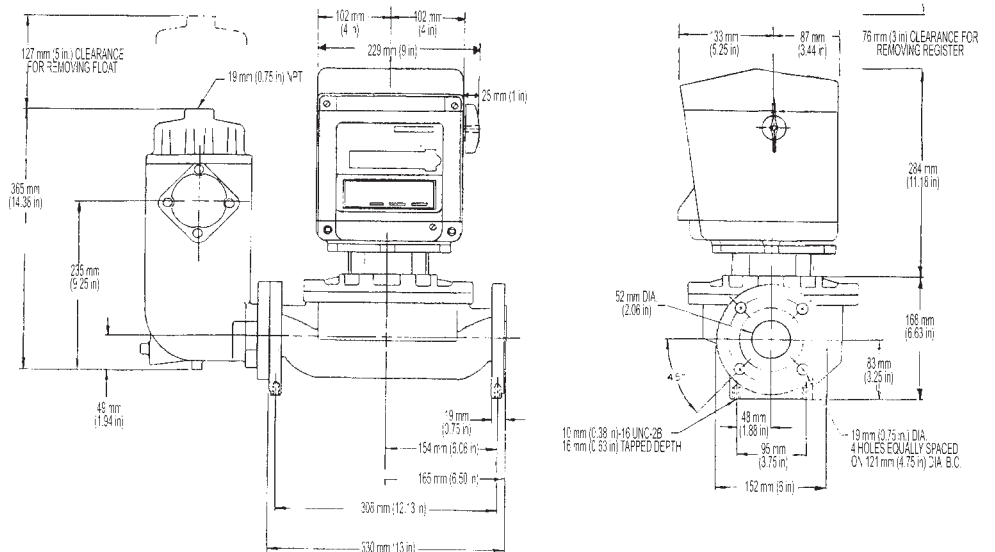

2" Type MP with 800 Series Register and Air/Release Strainer

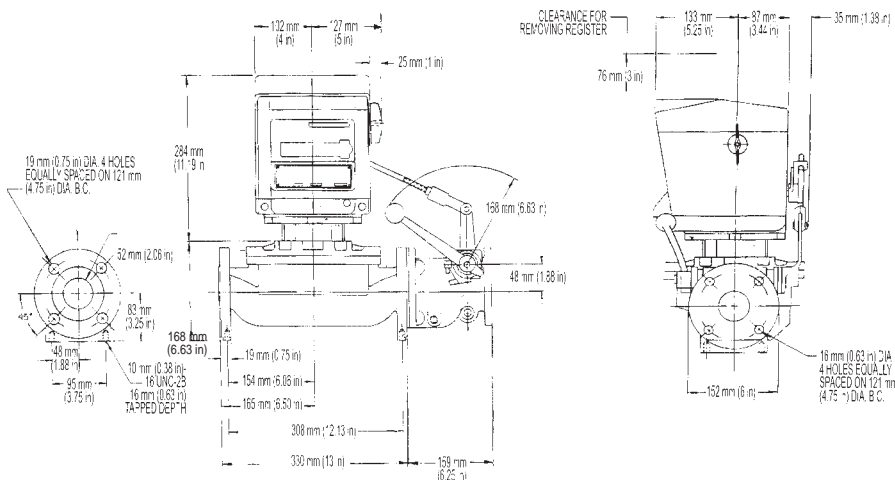

2" Type MP with 800 Series Register and Auto-Stop Valve

DIMENSIONAL DATA SIZE 3"

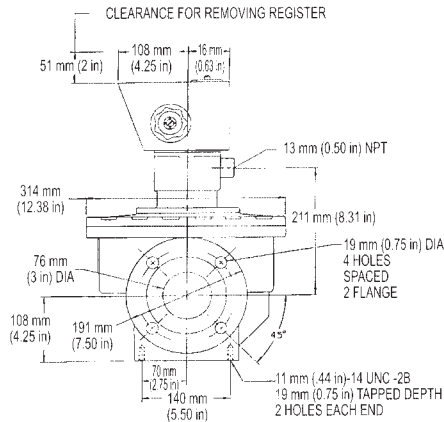
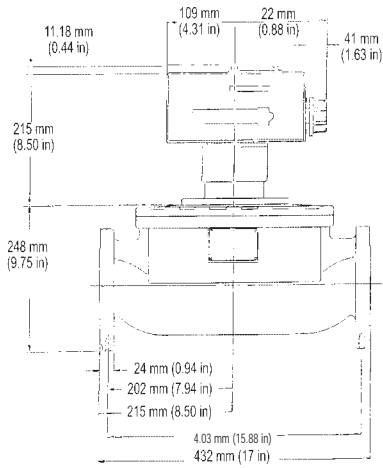

3" Type MP with 600 Series Register

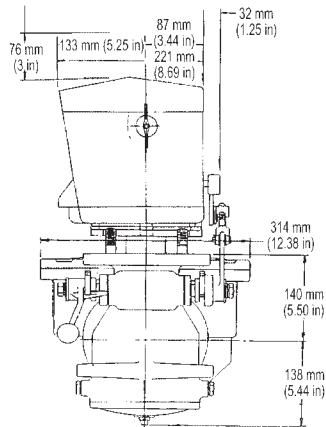
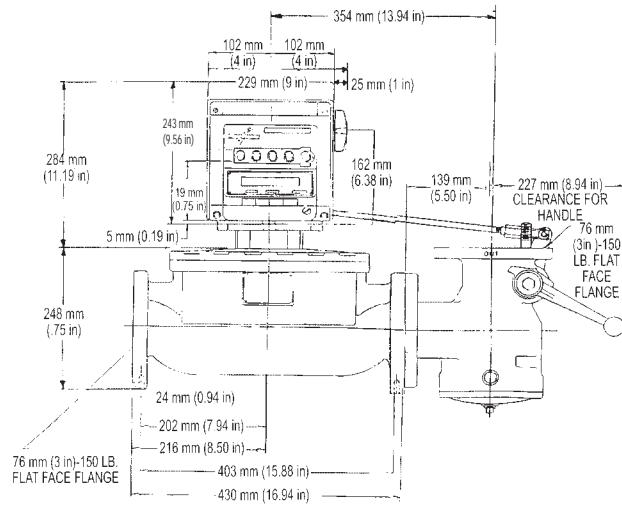

3" Type MP with 800 Series Register and Auto-Stop Valve

WEIGHT Kilograms (Pounds)										
	1/2" MP		1" MP		2" MP			3" MP		
	SM	SM	800	600	SM	800	600	SM	800	600
Stainless Steel	3.6 (8)	14 (30)	*21 (47)	15 (34)	39 (85)	45 (100)	40 (89)	49 (109)	59 (131)	52 (115)
Bronze	--	9 (20)	*17 (37)	11 (24)	32 (70)	39 (85)	34 (74)	57 (125)	67 (147)	59 (131)
Iron	--	11 (24)	*19 (41)	14 (31)	21 (46)	27 (60)	23 (50)	--	--	--

* Estimated Maximum Values



U.S.A./International:
1310 Emerald Road
Greenwood, SC 29646-8800
Tel.: Tol-Free (800) 833-3357
(864) 223-1212
Fax: (864) 223-0341

© 2002 Actaris Neptune Liquid Measurement Division 500 02/02

Specifications subject to change without prior notification.

