



## *Series MTX*

*Models 122, 123, 413, 420, 421, 433, & 444*

# **Installation, Operation & Maintenance Manual**



## *Table of Contents*

General .....	1
Installation .....	1
Register Removal .....	2
Measuring Chamber Disassembly .....	4
Reassembly .....	4
Specifications .....	5
Calibration .....	5
Replacement Parts .....	6
Model 840 & 860 Sensors .....	6

## *Installation, Operation & Maintenance*

### *GENERAL*

The Niagara series MTX flowmeters are ideal for the measurement of cold or hot water in commercial and industrial applications. These high performance meters are unsurpassed in the marketplace today.

The series MTX employs the latest technical achievements in multijet impeller meters. The impeller is the only moving part in the flow stream and is magnetically coupled to the register.

### *INSTALLATION*

In selecting an installation site one should consider readability, maintenance, and installation.

The Niagara series MTX meter must be mounted horizontally with the register on top.

In order to have accurate measurement, the meter must have a straight undisturbed pipe with length of five pipe diameters upstream and three pipe diameters downstream. If this is not possible, straightening vanes may have to be used.

The MTX must be placed in a pipeline free of scale, sediment, and debris. If there is excessive sediment in the pipeline, protect the meter by putting a strainer upstream of the meter.

Evacuate air from the meter before operating. Slowly open valve to let water into the meter. Gradually increase the flow rate to drive out the air. If the meter is not filled slowly, the surge of water can damage the measuring elements.

## REGISTER REMOVAL

### Models 122 & 123

(See Illustration 1)

1. Remove sealing wire (1).
2. Tap out clamping pins (2) from the register cover with a rod.
3. Take off register cover (3) and register (4). The register cannot be disassembled further. It is hermetically sealed and must be replaced as a unit if damaged.

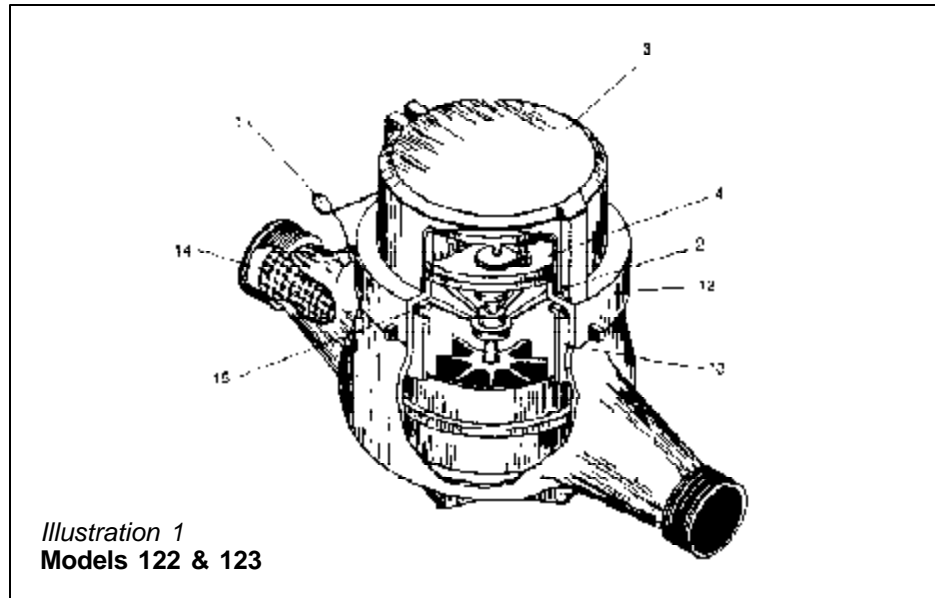

### Models 413 & 444

(See Illustration 2)

1. Remove sealing wire (1).
2. Remove strain relief nut (2) and draw out washer and binding nut.
3. Remove sealing screws (3) and lift off register cover (4).
4. Remove screw (5) and take off reed switch (6).
5. Remove sealing wire (7).
6. Lift sealing segment (8) out of ring. Turn working clamp ring (9) by 90 degrees to the left or the right and lift off.
7. The register (10) cannot be disassembled further. It is hermetically sealed and must be replaced as a unit if damaged.

### Models 420 & 421

(See Illustration 3)

1. Remove strain relief nut (1) and draw out washer and binding nut.
2. Remove sealing screws (2) and lift off register cover (3).
3. Pull reed switch or infrared transmitter (4) out of the register.
4. Remove sealing wire (5).
5. Pull sealing segment (6) out of ring.
6. Turn working clamp ring (7) and register (8) 90 degrees to the left or the right and lift off.
7. The register cannot be disassembled further. It is hermetically sealed and must be replaced as a unit if damaged.

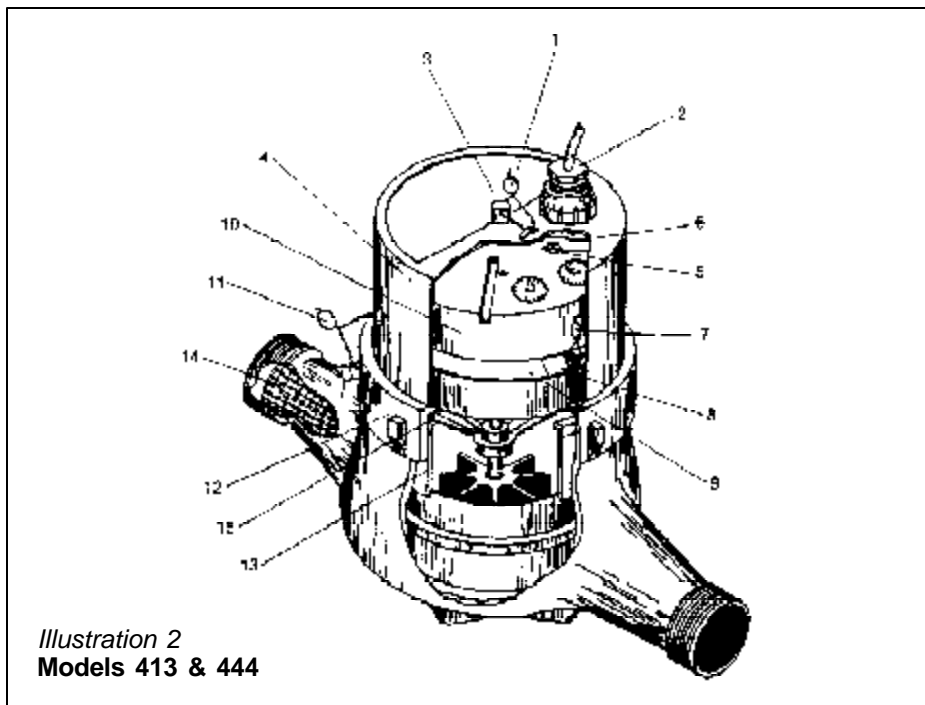

Illustration 2  
Models 413 & 444

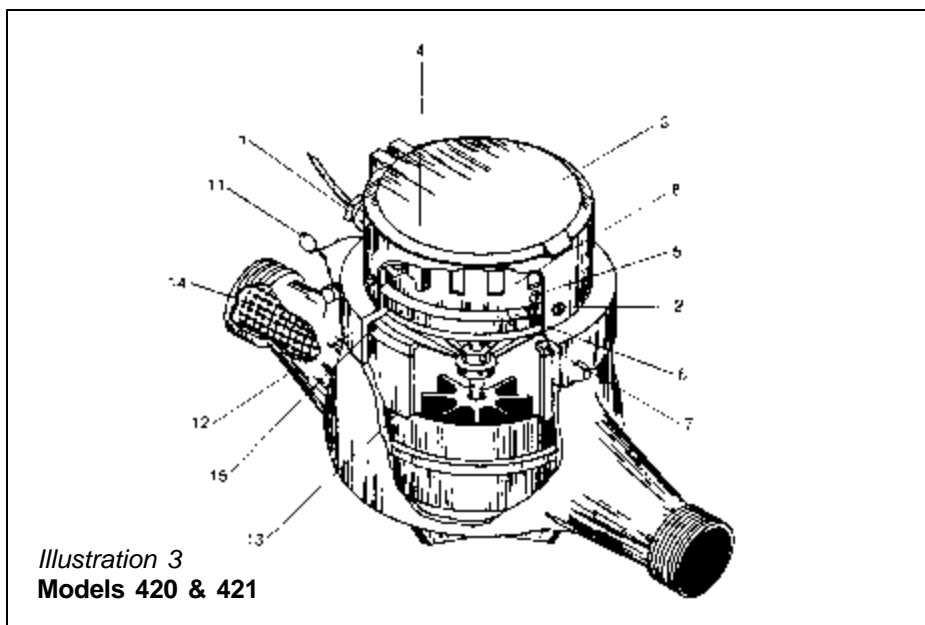
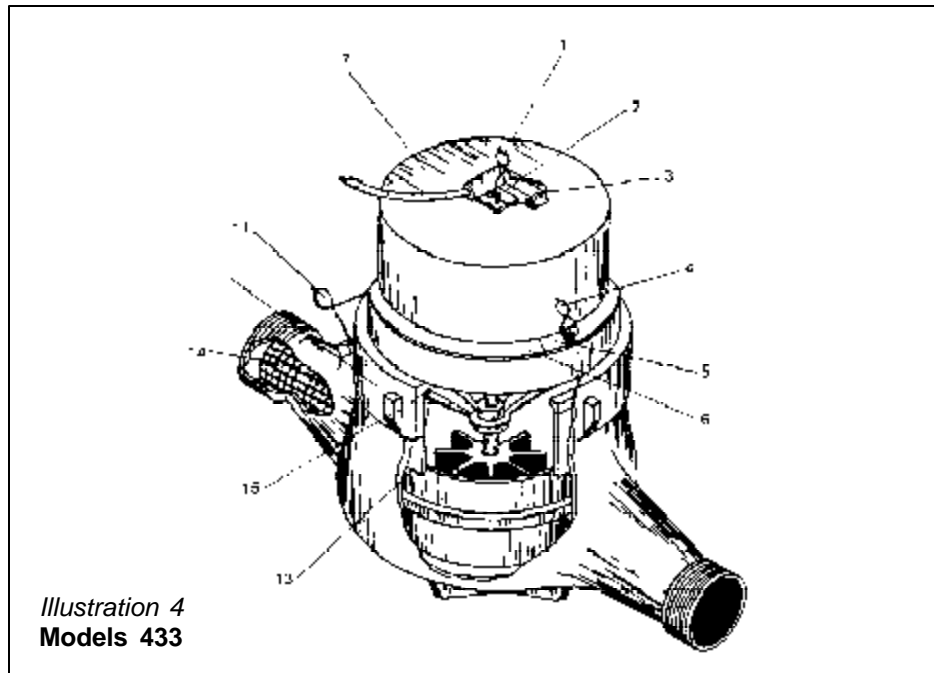

Illustration 3  
Models 420 & 421

**Model 433**

(See Illustration 4)

1. Remove sealing wire (1).
2. Take off reed switch (3) by removing cap screw (2).
3. Remove sealing wire (4) on sealing segment (5).
4. Lift out sealing segment (5).
5. Turn working clamp ring (6) with register (7) 90 degrees to the left or the right and lift off. The register cannot be disassembled further. It is hermetically sealed and must be replaced as a unit if damaged.



### ***MEASURING CHAMBER DISASSEMBLY***

1. Remove sealing wire (11) on Models 413, 420, and 433.
2. Turn upper case (12) with spanner wrench counter-clockwise and remove.
3. Measuring chamber (13) will fall out of the body by tilting it. If the measuring chamber is stuck, it can be removed by protecting one of the threaded connections with a cap nut and striking the protected end on a piece of wood.

***Caution should be used to protect the measuring chamber from damage.***

4. If the measuring unit is worn or damaged it must be replaced as a unit.
5. The filter (14) can be pushed out. Clean and check for damages. Replace if necessary.

### ***REASSEMBLY***

#### **Models 122 & 123**

*(See Illustration 1)*

1. Reassembly of the meter can be done by following the reverse order of the disassembly instructions. Check parts for wear and make sure they are clean.
2. Place O-ring on measuring chamber and insert chamber in meter. The measuring chamber must be flush with the bottom case of the meter.
3. To achieve a good seal, the O-ring (15) in the upper case should be slightly lubricated.
4. Replace sealing wire (1).

#### **Models 413 & 444**

*(See Illustration 2)*

1. Reassembly can be done by following the reverse order of disassembly instructions. Check parts for wear and make sure they are clean.

## *Series MTX*

2. Before putting register cover (4) on, working clamp ring (9) and sealing segment (8) have to be sealed with a sealing wire.
3. Reed switch (6) must be mounted in the slot above the magnet on the register. Replace screw.
4. Place O-ring on measuring chamber and insert chamber in meter. Measuring chamber (13) must be flush with the bottom case of the meter.
5. To achieve a good seal, the O-ring (15) in the upper case (12) should be slightly lubricated.

### **Models 420 & 421**

*(See Illustration 3)*

1. Reassembly of the meter can be done by following the reverse order of the disassembly instructions. Check O-rings and parts for wear and make sure they are clean.
2. Place O-ring on measuring chamber and insert chamber in meter. The measuring chamber (13) must be flush with the bottom case of the meter.
3. Place transmitter in the correct slot:  
X0.1: Infrared transmitter  
X1: Reed switch for one, pulse per 10 gallons  
X10: Reed switch for one, pulse per 100 gallons
4. Before putting register cover (3) on, working clamp ring (7) and sealing segment (6) have to be sealed with sealing wire.
5. When inserting register in cover, match slot above multiplier on register with tab inside cover.
6. To achieve a good seal, the O-ring (15) in the upper case should be slightly lubricated.

### **Model 433**

*(See Illustration 4)*

1. Reassembly can be done by following the reverse order of the disassembly instructions. Check parts for wear and make sure they are clean.
2. The working clamp ring (13) and sealing segment (2) have to be sealed with a sealing wire.
3. Place O-ring on measuring chamber and insert chamber in meter. The measuring chamber (13) must be flush with the bottom case of the meter.
4. To achieve a good seal, the O-ring (15) in the upper case (12) should be slightly lubricated.

## ***SPECIFICATIONS***

**Pressure:** 250 psi

**Accuracy:**  $\pm 1\%$

**Registration:** US gallons. Other units of measure available (consult factory).

### **Wetted material of construction:**

Body: High strength brass (3/4 – 1-1/2"); epoxy-coated cast iron (2" only).

Measuring element: 120°F, Polystyrene; 250°F, Noryl.

Impeller: 120°F, Polystyrene; 250°F, Noryl.

O-ring seals: EPDM

## ***CALIBRATION***

The meter is calibrated at the factory. If the measuring chamber is replaced, calibration instructions will be included with the replacement kit.

**REPLACEMENT PARTS**

- Measuring chamber complete
- Register assembly

Note: Part numbers for above items are listed in the parts price book.

**MODEL 840 & 860 SENSORS**

For installation and wiring of 840 and 860 Sensors, refer to manual M551.

**Models 123 (Cold) & 122 (Hot)**

Size		3/4"	1"	1-1/2"	2"
Flow Rate		1-20 gpm	2-50 gpm	3-85 gpm	4-130 gpm
Temperature	Cold	120°F	120°F	120°F	120°F
	Hot	250°F	250°F	250°F	250°F

**Model 413 (Hot) & Model 444 (3/4" ONLY)**

Size		3/4"	1"	1-1/2"	2"
Flow Rate		1-20 gpm	2-50 gpm	3-85 gpm	4-130 gpm
Temperature		250°F	250°F	250°F	250°F
Gallons per contact		1	1	10	10

**Models 420 (Cold) & 421 (Hot)**

Size		3/4"	1"	1-1/2"	2"
Flow Rate		1-20 gpm	2-50 gpm	3-85 gpm	4-130 gpm
Temperature	Cold	120°F	120°F	120°F	120°F
	Hot	250°F	250°F	250°F	250°F
Gallons per contact with 840 switch		10 or 100	10 or 100	10 or 100	10 or 100
Full scale freq. Hz w/860 pulser	Cold	20.63	16.66	14.16	21.66
	Hot	38.57			
Pulses/gallons	Cold	61.89	20	10	10
	Hot	115.71			

**Model 433 (Cold)**

Size		3/4"	1"	1-1/2"	2"
Flow Rate		1-20 gpm	2-50 gpm	3-85 gpm	4-130 gpm
Temperature		250°F	250°F	250°F	250°F
Gallons per contact		1	1	10	10



150 Venture Boulevard  
Spartanburg, SC 29306

Phone: (800) 778-9251, (864) 574-3327  
 Fax: (864) 574-8063  
 Internet: [www.aaliant.com](http://www.aaliant.com)  
 E-Mail: [sales@aaliant.com](mailto:sales@aaliant.com)