



*BTU Measurement System
Model 7431 & 7437
Calculator & Sensor*

**Installation, Operation
& Maintenance Manual**

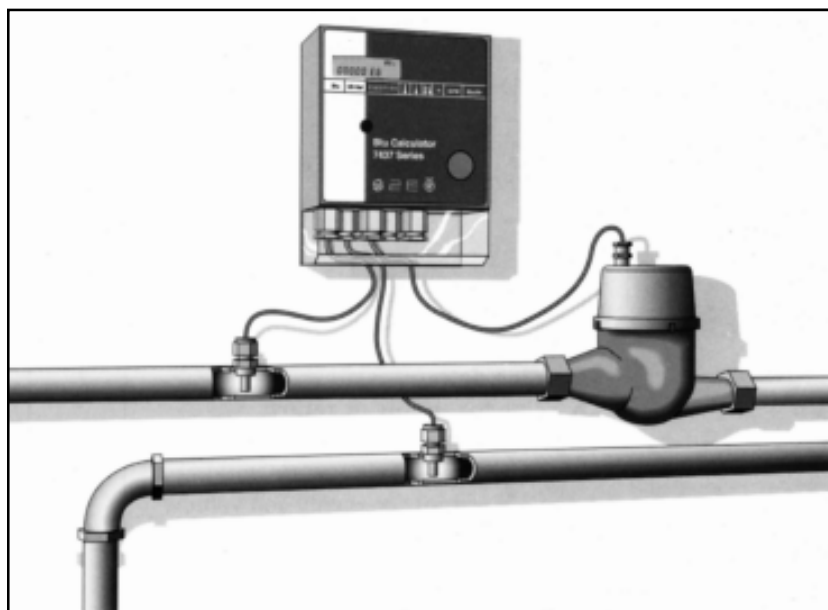

Table of Contents

General	1
Typical Applications	1
Features	1
Specifications	2
Dimensions	4
Installation	5
Unpacking	5
Flowmeter	5
Sensor	5
BTU Calculator	6
Wiring	6
Start Up	14
Operation	14

Installation, Operation & Maintenance

GENERAL

The BTU systems are applicable wherever energy consumption information is required. They are used to measure individual energy consumption in virtually any liquid heating/cooling system such as apartment complexes, office buildings, and condominiums. These systems are also used to measure performance of energy saving systems or the loss of efficiency which is directly tied to loss of revenue.

A BTU system consists of a calculator, a flowmeter, and a pair of temperature sensors. Matched RTD temperature sensors measure the change in temperature between the supply and return fluid lines. At the same time, the liquid flowmeter/transmitter monitors flow. These measurements are transmitted to the microprocessor in the calculator. It translates this information into BTUs of heating or cooling and displays consumption.

The calculator has LCD readout and push-button scrolling of parameters such as energy, volume, high temperature, low temperature, temperature differential, hours of operation, flow rate, BTU rate, service parameters, and more.

TYPICAL APPLICATIONS

- Multi-zone heating or cooling
- District heating or cooling
- Waste heating recovery
- Solar heating, preheating, or domestic hot water

FEATURES

- Highly accurate
- Identifies areas where energy can be saved
- Allocate charges to individual consumers or departments within heating or cooling systems
- Evaluate equipment efficiency
- Security seals
- Pulse output for remote totalization or computer interface
- Nonvolatile memory retains counts in case of power outage
- High reliability
- Easy installation

SPECIFICATIONS

A BTU system must contain:

- One BTU microprocessor calculator with LCD
- A flowmeter with contact, pulse transmitter or digital output
- Two temperature sensors — one for hot and one for cold

Calculator

Display: Eight-digit LCD readout with special signs for units

Housing rating: IP65 (splashproof)

Temperature sensing range: 32 to 392°F (0 to 200°C)

Operating temperature range: 32 to 122°F (0 to 50°C)

Temperature differential: 0.1 to 324°F

Power: See chart. Battery units have lithium battery, life five plus one years (3.6 VDC)

Volume units:

- Meters with contact closure:
1, 10, 100, 1000 gals./pulse or
1, 10, 100, 1000 pulses/gal.
- Meters with fast pulse output from 0.0043 to 6553.0 pulses/gal.

Output relays: (Model 7437) For energy and volume pulses and error alarm signaling.

Contact ratings:

- 500 mA maximum current
- 50 VAC, 75 VDC max. voltage

Open-collector transistor outputs (7431s): For energy and volume pulses.

Output ratings:

- Duration of 0.5 seconds
- 10 mA maximum current
- 40 VDC maximum voltage

Mounting: Wall

Weight: Calculator with sensor pairs

- 7431s – 0.9 lb.
- 7437s – 2.0 lbs.

Flowmeter Compatibility

MTX, WPX, or other turbine meters with contact closure, pulse transmitter, electromagnetic meters, or strain gage target meter with a 1050 transmitter. See chart.

Accuracy: See meter literature.

BTU Measurement System

Temperature Sensors

Type: 500 ohms platinum

Lengths: 3-5/16" (84 mm); 6-13/16" (174 mm)

RTD cable length: 6 feet

Fitting: 1/4" NPT; one fitting per sensor

Thermowells: 2" or 4"

System accuracy: Determined by accuracy of the flowmeter

Warranty: Standard one year on calculators, sensors and meters

	7431	7431 B	7437
Power:			
One battery			•
115 VAC, 60 Hz (743__-1)	•		•
230 VAC, 50 Hz (743__-2)	•		•
12 - 24 VDC external (743__-3)	•		•
Memory: EEPROM (nonvolatile)	•	•	•
Units of measure:			
BTU US gal. °F	•	•	•
Flowmeter input pulses:			
Slow gal./p	•	•	•
Fast p/gal.	•	•	•
Auxiliary two pulse inputs	•	•	•
Reading date	•	•	•
K value for supply or return	•	•	•
Open-collector pulse output for energy and volume	•	•	
Contact output for energy and volume			•
Contact output for error alarm			•
Flowmeters			
MTX, WPX turbine	•	•	•
Magnetic	•	•	•
Strain gage target with 1050	•	•	•
Temperature sensors			
Pt. 500 two-wires with shield	•	•	•
Pt. 500 four-wires with shield			•

DIMENSIONS

Model 7431

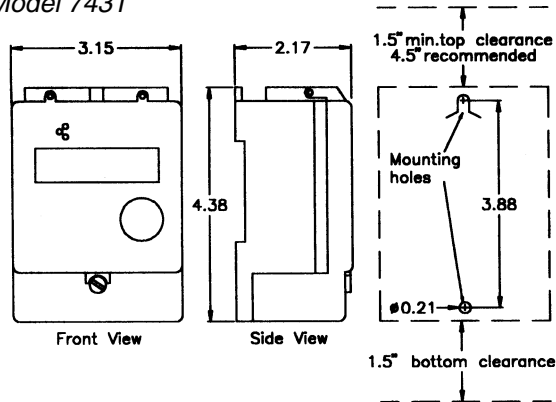

Model 7437

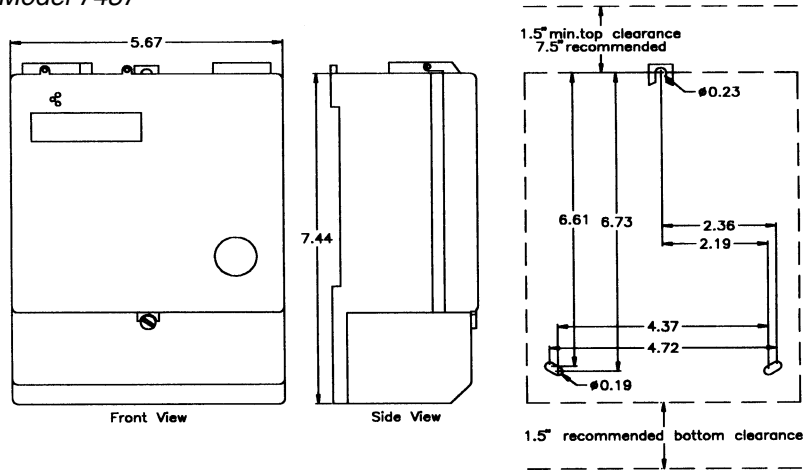

Model 7437

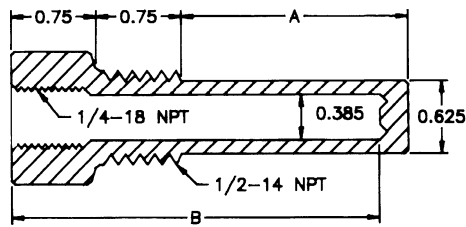

	Insertion Length 'A'	Element Length 'B'
3.5" Brass Well	2"	3.25"
5.5" Brass Well	4"	5.25"

INSTALLATION

Unpacking

Each box contains one system which includes a calculator a flowmeter and a pair of temperature sensors. Do not separate component parts because the three parts have been calibrated as one system.

As you unpack each system, notice that each component in the system has CIN tags. CIN labels are numbered by system in order to help identify system components wherever there is more than one system. Do not remove these tags. Also make note of the serial number on the name plate of the calculator and meter.

Flowmeter

Refer to the flowmeter manual for proper installation.

Sensors

Temperature sensors may be installed in fluid lines by mounting in a tee or by tapping piping directly. The tee is the preferred method in order to prevent leaks.

First, install the well. Next, fill the well with enough thermally conductive oil so that when the temperature sensor is inserted, it will displace any remaining air in the well.

When installing the sensors, the depth of the sensor will vary depending on the line size and whether you are using a thermowell or mounting tee.

The sensors should be installed in the piping system so that the tips of the sensors are located away from the pipe wall. This minimizes the effects of heat loss along the pipe wall. The two temperature sensors have been designated (red CIN – warmer) or (blue CIN – cooler) during factory calibration. Be sure the sensors are installed in the appropriate pipes.

Note: When the compression fitting is tightened onto the RTD tubing, make sure that the cable crimp impressions on the RTD are external to the compression fitting.

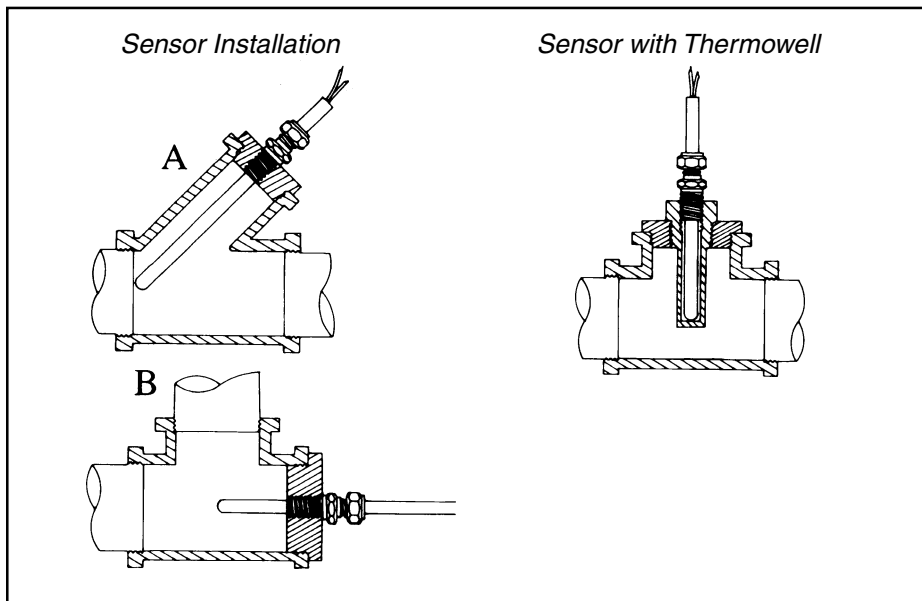

BTU Calculator

The following factors should be considered when selecting a location for the unit:

- Convenience of reading.
- Ease of wiring.
- Length of wire needed.
- The power supply line should be free of inductive loads (motors, starters, etc.) and any noise producing devices.
- Absence of area vibration and shock.

The calculator of the system is designed to be wall mounted by the enclosure mounting tabs.

Wiring

- It is highly recommended to use shielded, twisted-pair cable for wiring of temperature sensors and the flowmeter. Connect the shield to ground at the instrument end only.
- Do not route sensor wire in the same conduit or along side of AC power lines. Do not route sensor wires near electrically noisy devices such as motors, transformers, relays, CRTs (television sets or computer monitors), or other inductive noise sources.

Temperature Sensor Wiring

- If it is necessary to add cable for installation of the temperature sensors, equal amounts of cable must be added to both sensor cable runs when using two-wire RTDs.
- If additional cable is installed, clean wiring connections before splicing. Solder splices if possible. When adding additional cable, use the largest size of cable possible. 18 AWG stranded wire is acceptable.
- Temperature sensor cabling must be kept dry at all times to avoid resistance changes due to corrosion.

Calculator Wiring

Refer to wiring drawings. Check all wiring, making sure all connections are tight.

Model 7431 terminal wiring information

Miniaturized terminal blocks are used for making wiring connections. The wire is held in place within the terminal with spring-force action that provides excellent contact without damage to the wire, even in a high-vibration environment. Solid or stranded wire may be used.

A terminal tool is provided that may be used to leverage the terminal contact open while the wire is inserted. A small blade screwdriver may also be used to press the contact open. Once the wire is in place and the tool is removed, the contact spring will provide a constant force against the wire to securely hold it in place.

Model 7437 Wiring Terminal Information

Terminal wiring connections for the 7437 series calculators are screwtype and will accommodate wire sizes to 14 AWG. The terminal blocks are pluggable so that they may be removed to facilitate wiring.

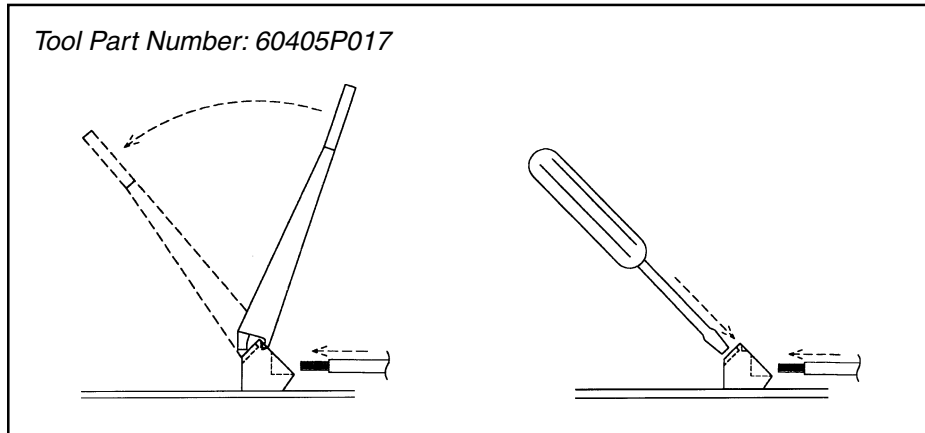

Electronic pulse outputs

Models 7431 except 7431 Bus

Two pulse outputs are available in the 7431 calculator. The outputs are in the form of open-collector transistors (emitter grounded). Terminal 16 is an energy pulse. Terminal 18 is a volume pulse. Terminals 17 and 19 are respective DC common (ground) terminals. To use the pulse outputs, a pull-up resistor must be connected between the output terminal and a DC voltage. The voltage maximum is 40 VDC. The current through the transistor output must be limited to 10 mA maximum. A pull-up resistor of 1K to 10K ohms is suggested. The output pulse, taken from between the resistor and the output terminal, is suitable for a remote electronic counter, data acquisition system, PLC, etc. The DC common of the supplying voltage source should be connected to terminals 17 and/or 19 of the energy calculator.

Contact pulse outputs

Model 7437 except 7437A

Contact pulse outputs represent energy and volume and may be used for remote totalization. The alarm output is a contact output that remains switched when an error condition exists. Contact outputs for Model 7437 are the reed relay type and are rated at 500 mA maximum current and 50 VAC or 75 VDC maximum voltage.

Flowmeter input wiring

The BTU calculator may accept contact closure or electronic pulse type inputs from a flowmeter or transmitting device. The type of input and input scaling factor must be programmed into the calculator at the factory. Contact closure type inputs are connected to terminal block positions 10 and 11. The scaling units may be selected from 1, 10, 100, and 1000 gallons per pulse and from 1, 10, 100, and 1000 pulses per gallon. The contact input pulse frequency must be less than 2 Hz.

Electronic pulse inputs may also be accepted into the BTU calculator. A current-sourcing pulse input may be connected to terminal 10, while the source's DC common is connected to terminal 11. Terminal 9 provides a low current voltage source for inputs from open-collector transistor (current-sinking) type devices. The voltage at terminal 9 is 3.6 VDC. The scaling factor for electronic type pulse inputs may be in the range of 0.0043 to 6553.5 pulses per gallon. The maximum electronic pulse input frequency is 100 Hz.

Model 7431 – (1, 2, 3)

Read all wiring instructions before wiring.

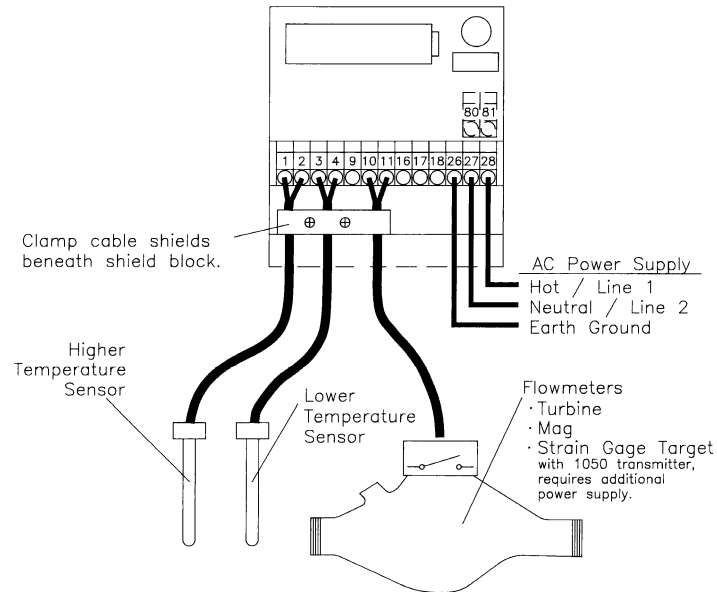

Wiring Terminal Functions

- 1 High temperature sensor (red)
- 2 High temperature sensor (white)
- 3 Low temperature sensor (red)
- 4 Low temperature sensor (white)
- 9 Flowmeter power supply (3.6V at 20 uA)
- 10 Flowmeter input (contact)
 - Contact: Turbine meter with:
 - 840 White connect to 10.
Brown not connected.
Black ground connect to 11.
 - 860 See *Model 7431 with 860 and power supply*, page 10.
When using an infrared pre-amp, a separate power supply is required. Yellow connect to 10.
 - Pulse:
 - Mag meter
 - Strain gage target
- 11 Flowmeter gnd. ref. (OV) (contact) (black)
- 16 O - C pulse output – energy
- 17 O - C output common (OV)
- 18 O - C pulse output – volume
- 26 Power supply earth ground (–1 and –2 versions only)
- 27 Power supply – line 2/neutral (–1 and –2 version only)
- 28 Power supply – line 1/hot (–1 and –2 versions only)
- 80 12 to 24 VDC power supply (–3 version only)
- 81 12 to 24 VDC power supply (–3 version only)

Model 7431 B (Battery)

Read all wiring instructions before wiring.

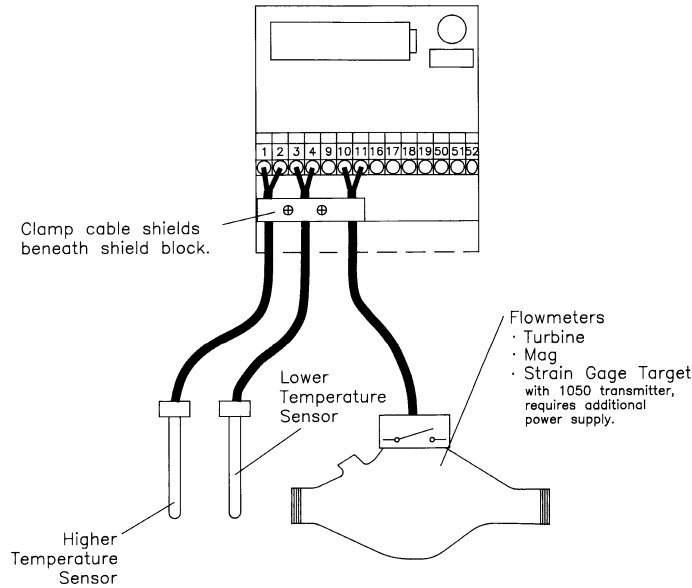

Wiring Terminal Functions

- 1 High temperature sensor (red)
- 2 High temperature sensor (white)
- 3 Low temperature sensor (red)
- 4 Low temperature sensor (white)
- 9 Flowmeter power supply (+V)
- 10 Flowmeter input (contact)
 - Contact: Turbine meter with:
 - 840 White connect to 10.
Brown not connected.
Black ground connect to 11.
 - 860 See *Model 7431 with 860 and power supply*, page 10.
When using an infrared pre-amp, a separate power supply is required. Yellow connect to 10.
 - Pulse: • Mag meter
 - Strain gage target
- 11 Flowmeter gnd. ref. (OV) (contact) (black)
- 16 O - C pulse output – energy
- 17 O - C output common (OV)
- 18 O - C pulse output – volume
- 19 O - C output common (OV)
- 50 Auxiliary pulse input A
- 51 Auxiliary input common (OV)
- 52 Auxiliary pulse input B

Model 7431 with 860 and Power Supply

Read all wiring instructions before wiring.

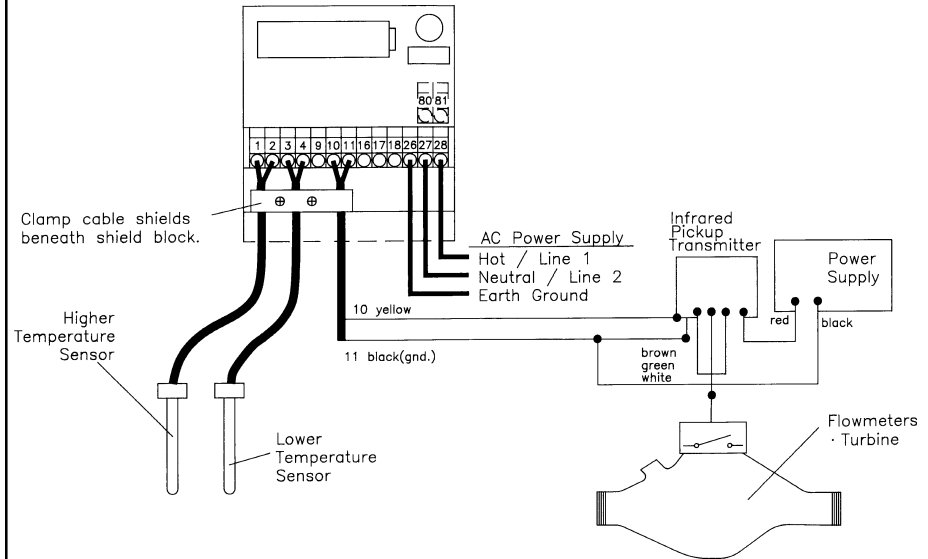

Wiring Terminal Functions

- 1 High temperature sensor (red)
- 2 High temperature sensor (white)
- 3 Low temperature sensor (red)
- 4 Low temperature sensor (white)
- 9 Flowmeter power supply (+V)
- 10 Flowmeter input (contact)
 - Contact: Turbine meter with:
 - 840 White connect to 10.
Brown not connected.
Black ground connect to 11.
 - 860 See *Model 7431 with 860 and power supply*, above.
When using an infrared pre-amp, a separate power supply is required. Yellow connect to 10.
- 11 Flowmeter gnd. ref. (OV) (contact) (black)
- 16 O - C pulse output – energy
- 17 O - C output common (OV)
- 18 O - C pulse output – volume
- 26 Power supply earth ground (A and –2 versions only)
- 27 Power supply – line 2/neutral (–1 and –2 version only)
- 28 Power supply – line 1/hot (A and –2 versions only)
- 80 12 to 24 VDC power supply (–3 version only)
- 81 12 to 24 VDC power supply (–3 version only)

Model 7431 Bus

Read all wiring instructions before wiring.

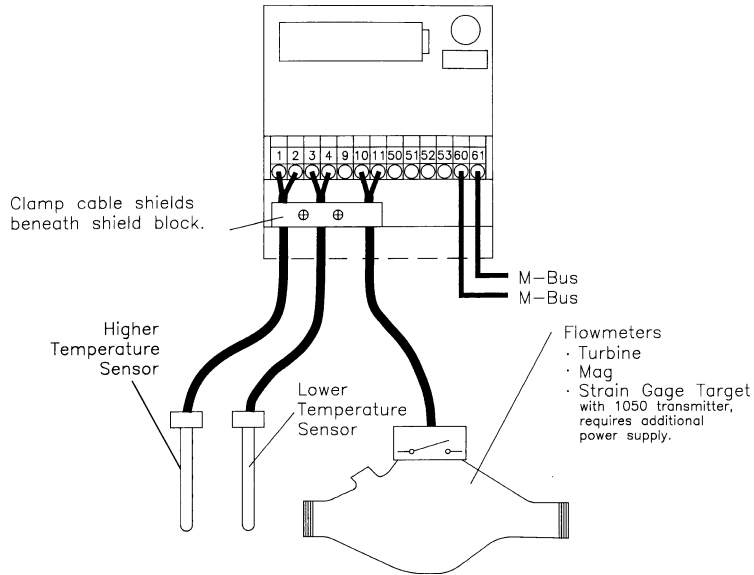

Wiring Terminal Functions

- 1 High temperature sensor (red)
- 2 High temperature sensor (white)
- 3 Low temperature sensor (red)
- 4 Low temperature sensor (white)
- 9 Flowmeter power supply (+V)
- 10 Flowmeter input (contact)
 - Contact: Turbine meter with:
 - 840 White connect to 10.
 - Brown not connected.
 - Black ground connect to 11.
 - 860 See *Model 7431 with 860 and power supply*, page 10.
 - When using an infrared pre-amp, a separate power supply is required. Yellow connect to 10.
- Pulse: • Mag meter
 - Strain gage target
- 11 Flowmeter gnd. ref. (OV) (contact) (black)
- 50 Auxiliary pulse input A
- 51 Auxiliary input common (OV)
- 52 Auxiliary pulse input B
- 53 Auxiliary input common (OV)
- 60 M-Bus connection
- 61 M-Bus connection

Model 7437 – (1, 2, 3)

Read all wiring instructions before wiring.

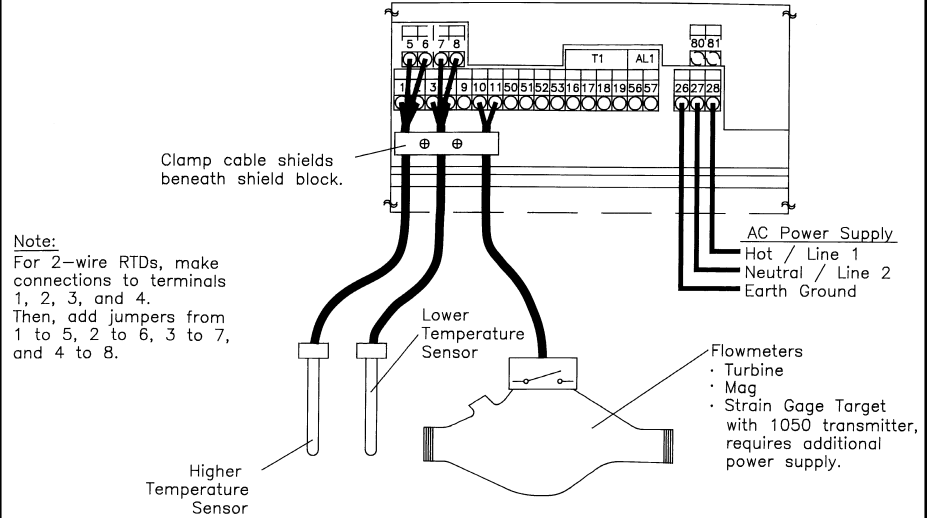

Wiring Terminal Functions

- 1 High temperature sensor (excitation +) (red)
- 2 High temperature sensor (excitation -) (white)
- 3 Low temperature sensor (excitation +) (red)
- 4 Low temperature sensor (excitation -) (white)
- 5 High temperature sensor (sense +) (red)
- 6 High temperature sensor (sense -) (white)
- 7 Low temperature sensor (sense +) (red)
- 8 Low temperature sensor (sense -) (white)
- 9 Flowmeter power supply (+3.6 VDC at 20 uA)
- 10 Flowmeter input (contact)
 - Contact: Turbine meter with:
 - 840 White connect to 10.
 - Brown not connected.
 - Black ground connect to 11.
 - 860 See *Model 860*, page 6. When using an infrared pre-amp, a separate power supply is required. Yellow connect to 10.
- Pulse:
 - Mag meter
 - Strain gage target
- 11 Flowmeter gnd. ref. (OV) (contact) (black)
- 50 Auxiliary pulse input A
- 51 Auxiliary input common (OV)
- 52 Auxiliary pulse input B
- 53 Auxiliary input common (OV)
- T1-16 Contact output – energy pulse
- T1-17 Contact output – energy pulse
- T1-18 Contact output – volume pulse
- T1-19 Contact output – volume pulse
- AL1-56 Contact output – error alarm
- AL1-57 Contact output – error alarm
- 26 Power supply earth ground (-1 and -2 versions only)
- 27 Power supply – line 2/neutral (-1 and -2 versions only)
- 28 Power supply – line 1/hot (-1 and -2 version only)
- 80 12 to 24 VDC power supply (-) (-3 version only)
- 81 12 to 24 VDC power supply (+) (-3 version only)

Model 7437A (2, 4) (B, D) – (1, 2,)

Read all wiring instructions before wiring.

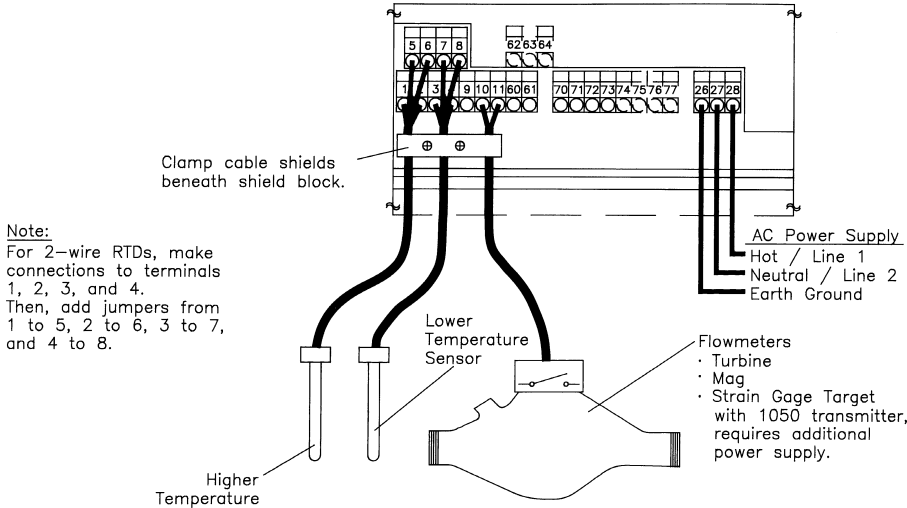

Note:
For 2-wire RTDs, make connections to terminals 1, 2, 3, and 4. Then, add jumpers from 1 to 5, 2 to 6, 3 to 7, and 4 to 8.

Flowmeters
• Turbine
• Mag
• Strain Gage Target with 1050 transmitter, requires additional power supply.

Wiring Terminal Functions

- 1 High temperature sensor (excitation +) (red)
- 2 High temperature sensor (excitation -) (white)
- 3 Low temperature sensor (excitation +) (red)
- 4 Low temperature sensor (excitation -) (white)
- 5 High temperature sensor (sense +) (red)
- 6 High temperature sensor (sense -) (white)
- 7 Low temperature sensor (sense +) (red)
- 8 Low temperature sensor (sense -) (white)
- 9 Flowmeter power supply (+3.6 VDC at 20 uA)
- 10 Flowmeter input (contact)
Contact: Turbine meter with:
 - 840 White connect to 10. Brown not connected. Black ground connect to 11.
 - 860 See *Model 7431 with 860 and power supply*, page 10. When using an infrared pre-amp, a separate power supply is required. Yellow connect to 10.
- Pulse:
 - Mag meter
 - Strain gage target
- 11 Flowmeter gnd. ref. (OV) (contact) (black)
- 60 M-Bus connection 1 (option B)
- 61 M-Bus connection 2 (option B)
- 62 RS-232 connection (option D)
- 63 RS-232 connection (option D)
- 64 RS-232 connection (option D)
- 70 Analog output 1
- 71 Analog output 1
- 72 Analog output 2
- 73 Analog output 2
- 74 Analog output 3 (option 4 only)
- 75 Analog output 3 (option 4 only)
- 76 Analog output 4 (option 4 only)
- 77 Analog output 4 (option 4 only)
- 26 Power supply earth ground
- 27 Power supply - line 2/neutral
- 28 Power supply - line 1/hot

START UP

Turn power on and start flow slowly through the meter to fill the line. The system will be operating properly providing there is flow through the meter and a differential temperature exists between the supply and return lines.

OPERATION

Energy transfer is calculated by obtaining the temperature of the fluid previous to and immediately after the fluid flows through a heat exchange device. The temperature is sensed by using RTD temperature sensors. The amount of fluid flow through the system is obtained by use of a flowmeter. The energy calculator computes the energy consumption/production as a function of temperature differential and fluid volume.

If the low temperature sensor is equal to or above the high temperature sensor, no energy is calculated. To change between heating and cooling operations, simply swap the wiring between the high temperature sensor and the low temperature sensor. (Wires to terminals 1 and 2 are interchanged with wires to terminals 3 and 4.) When inverting the operation, it is recommended to record the energy total because heating and cooling energy units are usually allocated differently.

Displayed Error Codes

If there is an operational fault, a code will be displayed that will designate the fault. Energy measurement is not calculated when there is an operational fault present. The codes are:

- Err 001** Error with the cold temperature sensor
- Err 002** Error with the hot temperature sensor
- Err 004** Temperatures are reversed. (Probes are crossed or heat flow is reversed.)
- Err 008** Temperature measurement circuit calibration error
- Err 016** Flow rate too high
- Err 032** Error on auxiliary pulse input A (> 1.5 Hz)
- Err 064** Error on auxiliary pulse input B (> 1.5 Hz)
(Only on Models 7431 B, 7431 Bus, and 7437)
- Err 128** Error in EEPROM memory
- Batt xxx** Power supply error or end of battery life reached. Possibly other errors exist simultaneously.

If more than one error type exists, the display message will be the summation of the individual error codes. Example: "Err 003" indicates errors within the cold and hot temperature sensors or sensor wiring.

BTU Measurement System

Standard Readouts

BTU	BTU (energy) units Total BTU consumption year to date	00142 E6 ^{BTU}
Volume	Units Total water volume	00620 E2 ^{gal}
Display test	Segment test	:8.8.8. .8.8.8.8
Auxiliary volumes	Units Total volume of flowmeter "A"	A 001505 ^{gal}
Auxiliary volumes	Units Total volume of flowmeter "B"	B 000020 ^{gal}
Supply temperature (in heating applications or the normally warmer RTD)	Warm temperature symbol Degrees in F	266.2 °F
Return temperature (in heating applications or the normally cooler RTD)	Cool temperature symbol Degrees in F	122.22 °F
Differential temperature	Two temperature symbols Temperature difference between the warm and cool in hundredths of °F	143.90 °F
Battery life Remaining battery life (Model 7431 B)	Life in hours	48180 h
Current flow rate For primary flowmeter	Units Flow rate in US gallons per minute	240 ^{gal/min}
Current BTU (Energy) For primary flowmeter	Units Present energy reading	1680 E4 ^{BTU/h}

Press and hold for 10 seconds

RTD type S Pt. 500

K pulse value of main flowmeter S 10 gal/p

Pulse value of auxiliary meter "A" S A 10 gal/p

Pulse value of auxiliary meter "B" S B 10 gal/p

Identification number
(unique per calculator) S 95019573

Hardware/software I.D. number S 431000

BTU (energy) at reading date S 00009 E6 BTU

Volume of main flowmeter
at reading date S 00405 E2 gal

Volume of auxiliary meter A
at reading date S A 000000 gal

Volume of auxiliary meter B
at reading date S B 000000 gal

Current date S 96.01.08

Current time 10H59 P

Optional display with Bus

Network address 1 to 250
(Model 7431 Bus) 250

Baud rate 300, 600, 1200,
or 2400 (Model 7431 Bus) 600



150 Venture Boulevard
Spartanburg, SC 29306

Phone: (800) 778-9251, (864) 574-3327

Fax: (864) 578-8063

Internet: www.aaliant.com

E-mail: sales@aaliant.com