

Specifications

Description

Featuring 4 ^{1/2} digits of rate and 8 digits of total, the PC58 is a battery powered indicator capable of accepting magnetic pickup, DC pulse and switch closure inputs. The unit can be ordered with an optional 4-20mA output. The PC58 uses the 4-20mA loop to provide power when this output is used.

Specifications

POWER:

BATTERY POWERED

Supplied with 2 C size Lithium battery pack.

EXTERNAL POWER INPUT

Voltage: 8.5 to 30 VDC

Current: Less than 5 mA

Supplied with 1 C size lithium battery

(battery must be installed to power display)

Protection: Reverse Polarity Protection on DC Power Input

LOOP POWERED

Voltage: 8.5 to 30 VDC

Supplied with 1 C size lithium battery

(battery must be installed to power display)

Protection: Reverse Polarity Protection on Current Loop

Loop Burden: 8.5V maximum

Battery Life Expectancy

RUN TIME

		Idle	2hrs/day	8hrs/day	24hrs/day
PC58	A	5 yrs	4.5 yrs	3.5 yrs	2.1 yrs
PC58	A 4	5 yrs	3.7 yrs	2.7 yrs	1.5 yrs
PC58	B/C Standby Operation	2.5 yrs	2.25 yrs	1.75 yrs	1 yr
PC58	B/C External or Loop Power	10 years			

All of the above values are calculated with the pulse output ON. Turn the pulse output OFF to prolong battery life up to 30%.

DISPLAY:

Rate Display: (selectable decimal)

4.5 Digits (59999), 0.35" High, Display updates once every two seconds

Rate Descriptors: /SEC, /MIN, /HR

Min. Input Frequency: .125 Hz to 10 Hz (selectable delay of 0.1 to 8.0 seconds)*

Totalizer Display: (selectable decimal)

8 Digits (99999999), 0.2" High

Totalizer Descriptors: GAL, LIT, FT3, M3, "blank"

Warning Displays: Low battery warning

PULSE OUTPUT:

The pulse output advances with the least significant digit of the totalizer.

Type: Opto-isolated open collector transistor.

Max. voltage (off state): 30 VDC

Current (on state): 5 mA @ .9 V drop, .1mA @ .7 drop

Pulse Rate / Duration: Selectable (see below)

SPEED (HZ)	1	2	4	8
Min. on/off (msec)	500	250	125	62.5

Pulse output divider: User selectable, ÷1, ÷10, ÷100 or OFF

NOTE: Select OFF for max. battery life.

ACCURACY:

0.01% Reading, ±1 count

Temperature Drift: 50 ppm/°C Worst Case

MOUNTING STYLES:

- 0- Circuit Board- OEM option (consult factory)
- 1- Panel Mount - NEMA 4X Front
- 2- Wall Mount - NEMA 4X Enclosure
(unit mounted behind clear cover)
- 3- Explosion Proof - Class I, Division I, Groups B, C & D
Class II, Division I, Groups E, F & G
- 5- Wall Mount - NEMA 4X Enclosure
(unit mounted on cover)

ENVIRONMENTAL:

OPERATING TEMPERATURE

-4°F (-20°C) to + 158°F (70°C)

Extended Temp: -22°F (-30°C) to + 158°F (70°C)

HUMIDITY

0 - 90% Noncondensing

INPUTS:

MAGNETIC PICKUP INPUT

Frequency Range: 0 to 3500 Hz

Trigger Sensitivity: 30 mV p-p

Over Voltage Protected: ± 30 VDC

OPTO-ISOLATED DC PULSE INPUT

High (logic 1): 4-30 VDC

Low (logic 0): Less Than 1 VDC

Minimum Current: .5 mA

Hysteresis: 0.4 VDC

Frequency Range: 0 to 5 kHz

Min. Pulse Width: 0.1 msec

CONTACT CLOSURE INPUT (contact closure to common)

Internal Pullup Resistor: 100 KΩ to +3.6 VDC

High (logic 1): Open or 4-30 VDC

Low (logic 0): Less Than .5 VDC

Internal Switch Debounce Filter: 0 to 40 Hz

CAUTION: Sustained contact closure will shorten battery life.

RESET INPUT (contact closure to common)

Internal Pullup Resistor: 100 KΩ to +3.6 VDC

High (logic 1): Open or 4-30 VDC

Low (logic 0): Less Than .5 VDC

Minimum On : 25 msec

CAUTION: Sustained contact closure will shorten battery life.

K-FACTOR

Range: 0.001 to 59999

Decimal Point Locations: XX.XXX to XXXXX

Factor Multiplier: Multiplies entered K-Factor by 1, 10, 100, 1000.

10 Point Linearization Option

This feature allows the user to enter 10 different frequencies with 10 different corresponding K-Factors to linearize non linear signals.

ANALOG OUTPUT OPTION:

Type: 4-20 mA follows rate display, Two wire hookup

Accuracy: 0.15% Full Scale at 20° C

Temperature Drift:

50 ppm/°C Typical

200 ppm/°C Worst Case

Reverse Polarity Protected

NOTE: The PC58 uses the 4-20 mA loop power as its power source when this option is used. The battery is still required to power the display.

* A large delay setting and internal math operations may delay the update rate.

Installation

Battery Installation and PC58 Initialization:

All PC58 models are shipped with the battery installed. This preserves battery life when the unit is not in service but requires that the PC58 hardware be initialized when the battery is installed. When using external BATPACK, mount within 12" and plug connector into 3 position square posts (see Fig 1). Polarity is not a concern because center is common.

To install the battery, begin by locating the battery holder. The PC58-2, 3 and 5 require opening the enclosure cover and removing the PC58 to expose the battery holder.

The plus terminal of the battery is marked with a (+) symbol stamped into the battery holder. Be sure to install the battery(ies) correctly.

Locate the "initialize" terminals on the PC58 PCB (see Fig1). Using a small length of wire, temporarily jumper across the initialize terminals. The unit will respond by showing its software version number and then illuminating the LCD display. See Programming Flowchart to setup desired operating parameters.

CAUTION : All PC58 models are provided with two or more sources of power. The power should not be interrupted when changing batteries. For models with two batteries, change one battery at a time. If all power sources are interrupted, information will be lost and the unit will have to be re-initialized as described above.

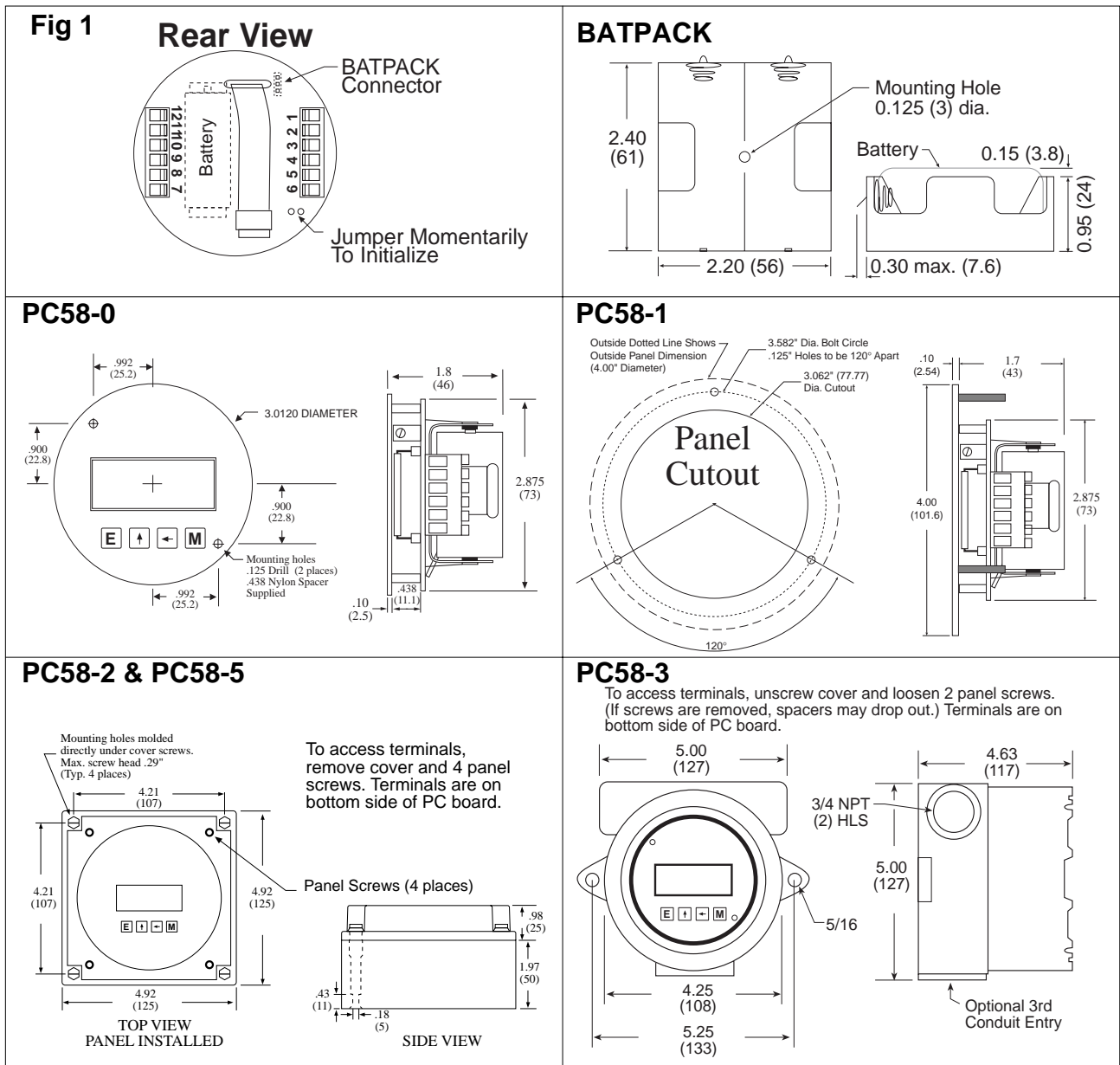

Theory of Operation

Flow rate equation:

$$\text{Flow Rate Indication} = \frac{\text{Input Frequency}}{\text{FAC} \times \text{FAC mul}} \times \text{Time Scaler}$$

Where Time Scaler is equal to: 1 for rate per second read out
 60 for rate per minute read out
 3600 for rate per hour read out

Flow total equation:

$$\text{Flow Total} = \frac{\text{Sum of Input Pulses}}{\text{FAC} \times \text{FAC mul}}$$

10 Point Linearization Option:

A 10 point linearization table is used to construct a curve describing the relationship of K-Factor and input frequency. The measured input frequency is used to access the table. A linear interpolation of adjacent point pairs is used to arrive at the K-Factor at that input frequency. The flow rate and total are then computed based upon the K-Factor for that measurement sample.

NOTE: For best performance and resolution choose as many decimal places as possible in the K-Factor.
 Example: Enter a K-Factor of 1 as 1.000.

Wiring

Several typical applications of the PC58 are shown below. Please observe that the various pulse inputs and power options may be intermixed in many ways to solve common applications. The isolated pulse output may be freely used so long as proper polarity is observed.

Caution: When 4-20 mA loop option is provided, the power wiring to the loop power option should always be to terminals (+) 12 and (-) 11. Accidental wiring to (+) 12 and (-) 6 should be avoided since excessive current flow may result.

Caution: The magnetic pickup input and contact closure input require isolated sensors for proper operation. Accidental connections to earth may result in erroneous operation of the analog output and/or excessive current flow.

Caution: Accidental connections from circuit common (3 or 6) to earth or terminal (11) may result in erroneous operation of the analog output and/or excessive current flow.

Typical Applications

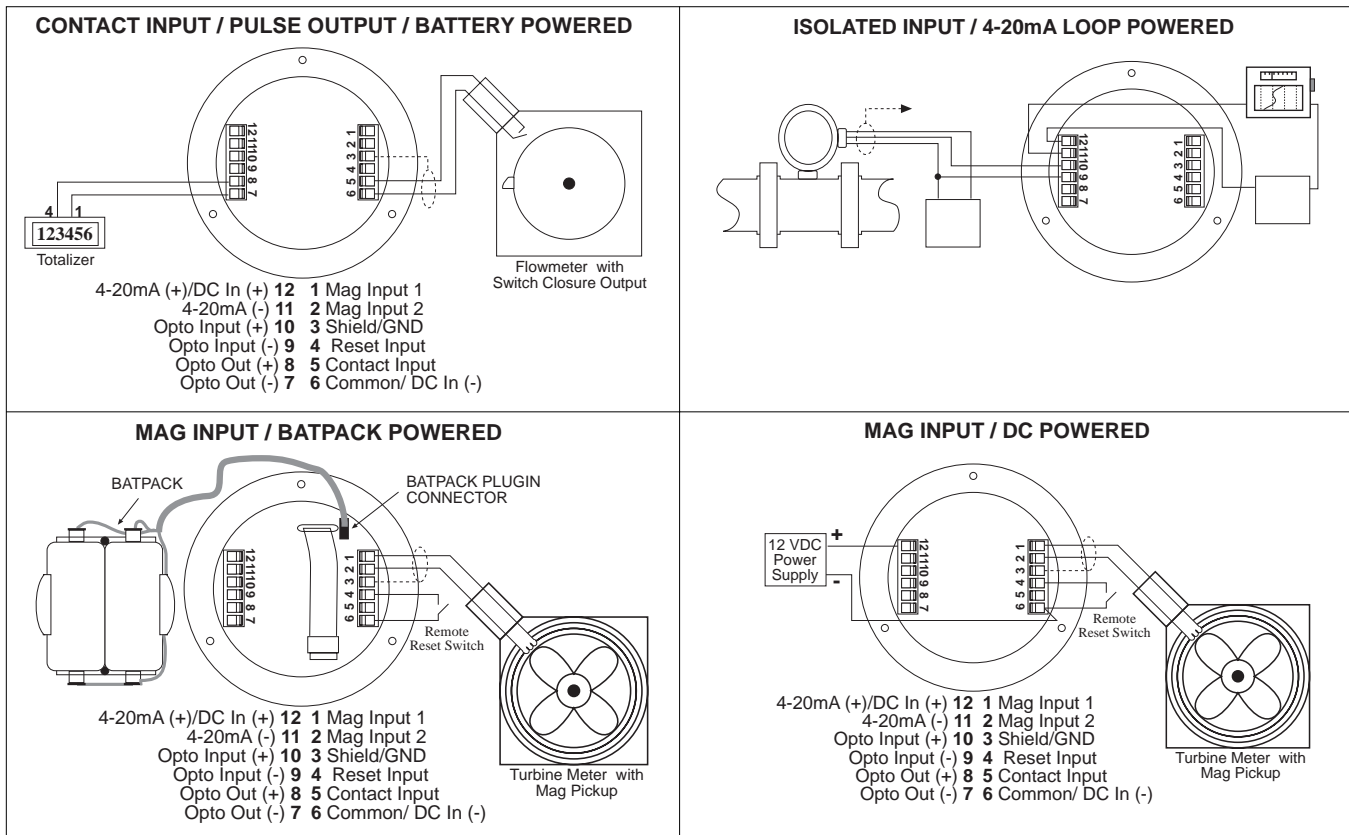

Definitions

ENT CODE: (enter code) This prompt will only appear if the panel lock is ON. Press the \uparrow key to increment each digit. Press the \leftarrow key to step to the next digit to the left. Press the **E** key to enter the 4 digit code. If the entered code is correct, the display will advance to the next menu prompt (CLr tot). If incorrect, the display will return to the run mode.

CLr tot: (clear total) Clears (resets) the totalizer. Press the **E** key to clear the total and return to the run mode. Press the **M** key to skip and advance to the next menu selection.

FAC mult: (factor multiplier) Sets the factor multiplier value. Press the \uparrow key to select 1, 10, 100, 1000. Press the **E** key to enter the displayed value.

FdEC: (factor decimal) Sets the decimal location for the factor. This location is restricted to 3 places (59.999). The use of this decimal automatically limits the number of decimal locations allowable in the rate and total to acceptable ranges. Press the \leftarrow key to move the decimal. Press the **E** key to select the displayed decimal location.

NOTE: For best performance and resolution choose as many decimal places as possible in the K-Factor.
Example: Enter a K-Factor of 1 as 1.000.

FAC LINEAR/ 10 POINT: (factor type) This prompt will only appear if the unit is ordered with the 10 point linearization option. The 10 POINT linearization selection is recommended for flow meters whose K-factors change with different flow rates. This selection allows users to enter up to 10 different frequencies (Fr 0 - Fr 9) with 10 corresponding K-factors (FAC 0 - FAC 9) for different flow rates. Beginning with Fr 0, enter "0" for the first frequency. If all 10 points are not needed, you can enter "0" for the frequency of any point to exit the 10 Point setup routine. This will save all of the values that have been entered up to that point.

The **LINEAR** setting is used for flow meters whose output is linear over its' entire operating flow range. Press the \uparrow key to step to the desired choice. Press the **E** key to enter the displayed factor type.

no/YES SET 10PT: (set 10 point?) This prompt allows the user to skip the 10 point setup routine. Select **YES** for initial setup or to change the present 10 point values. Select **no** to skip and keep the existing values.

FAC : (factor) This prompt appears on all units with linear inputs. The Factor is the number of pulses per unit volume for the flow sensor. The pulses/unit volume is implied by the totalizer descriptor when a descriptor is used. The implied units for the Factor are then as follows:

GAL	pulses/gallon
LIT	pulses/liter
FT3	pulses/ft3
M3	pulses/M3

Factors from 0.001 to 59999 may be used. A 0 value for the factor is not allowed and a warning message will be given. The factor is displayed on the subsidiary (lower) display. Press the \uparrow key to increment each digit. Press the \leftarrow key to step to the next digit to the left. Press the **E** key to enter the displayed factor.

Definitions

(continued)

Fr# : (frequency for point #) This prompt will only appear when 10 point selected. It sets the frequency for each of the 10 points (#). Press the ↑ key to increment each digit. Press the ← key to step to the next digit to the left. Press the **E** key to enter the desired frequency for the point #.

FR# : (factor for point #) This prompt will only appear when 10 point selected. It sets the factor for each of the 10 points (#). Press the ↑ key to increment each digit. Press the ← key to step to the next digit to the left. Press the **E** key to enter the desired factor for point #.

NOTE: The display will advance to the next point (Fr#) after each entry of the Fr & Fac until all 10 points are complete. entering a 0 in the Fr or fac setting will advance the display to the next menu prompt (tdec).

tdec : (totalizer decimal) Sets the decimal location for the totalizer. The totalizer decimal is not a dummy decimal and will scale the totalizer display accordingly. (i.e. if the tdec is set in the tenths position (1234567.8), 100 will be displayed as 100.0). The location of the decimal point allows for greater resolution of both the totalizer display and the pulse output. The pulse output advances at a rate dependent on the least significant digit of the totalizer. The totalizer decimal location is restricted to a maximum of 4 places (1234.5678). However, the number of totalizer decimal locations allowable is reduced with each decimal place added to the factor decimal. Press the ← key to move the decimal. Press the **E** key to enter the displayed decimal location.

Note:

The selection of the factor decimal point limits the available selections for the number of decimal points available for the totalizer. This is automatic.

Enter your selection of the Factor's decimal point before entering the totalizer decimal point to assure the proper selection of the totalizer decimal point has been made.

tot dESC : (totalizer descriptor) This allows you to illuminate one of the available descriptors on the display (GAL, LIT, FT3, M3 or "blank"). Press the ↑ key to select the descriptor. Press the **E** key to enter the selected descriptor.

SCALE : (ratemeter scaling) Sets the rate readout. Choose rate per hour (HR), minutes (MIN) or seconds (SEC). The scale setting is shown on the main (upper) display. Press the ↑ key to step to the desired choice. Press the **E** key to enter the displayed scale setting.

Note: A rate descriptor corresponding to the above choice will be illuminated on the display.

r decloc : (ratemeter decimal location) Sets the decimal location for the ratemeter. The ratemeter decimal is not a dummy decimal and will scale the rate display accordingly. (i.e. if the r decloc is set in the tenths position (123.4), 100 will be displayed as 100.0). The ratemeter decimal location is restricted to a maximum of 4 places (.1234). However, the number of ratemeter decimal locations allowable is reduced with each decimal place added to the factor decimal. Press the ← key to move the decimal. Press the **E** key to enter the displayed decimal location.

Note: The flow rate indicator will flash "59999" if the computed flow rate exceeds the 59999 display capability of the indicator. Choose a new decimal point location to avoid this.

Definitions

(continued)

DELY: (delay) Sets the amount of time (0.1 to 8.0 seconds) that the unit will "look" for valid input data. If pulses are not detected within this "window", the rate will display 0. The display will update once every two seconds as long as the unit receives valid data within two seconds. Some internal mathematics may delay this update. Press the \uparrow key to increment each digit. Press the \leftarrow key to step to the next digit to the left. Press the **E** key to enter the displayed delay value.

OUT LO: (out low) Sets the low setting for the 4-20 mA analog output. Key in the low rate value at which the unit will output 4mA. Press the \uparrow key to increment each digit. Press the \leftarrow key to step to the next digit to the left. Press the **E** key to enter the displayed out lo value.

OUT HI: (out high) Sets the high setting for the 4-20 mA analog output. Key in the high rate value at which the unit will output 20 mA. Press the \uparrow key to increment each digit. Press the \leftarrow key to step to the next digit to the left. Press the **E** key to enter the displayed out hi value.

PULSEOUT: (pulse out divider) This allows the unit to output a pulse for each least significant total count divided by the selected divider. The pulse out can be divided by 1 (1), 10 (10), 100 (100), or turned off (OFF). With the divider set at 1, the unit will give a pulse out for every increment of the LSD displayed.

Note: For maximum battery life, turn the pulse output off when pulse output is not used.

Selecting the proper pulse output divider may be needed so that the pulse output does not exceed the maximum rate of the pulse output (10 Hz). If the pulse output pulses too quickly a flashing display will result. Pressing the "M" key will result in a display of an error message "E PULSE". Press the "E" key to return to the run mode.

FREQOUT: (pulse out frequency) Sets the pulse output frequency / duration. Selections are: 1, 2, 4 or 8 Hz. This menu item is skipped if **PULSEOUT** is turned off.

LOCK CODE: (lock code) Sets the 4 digit lock code to be entered when the unit prompts **Enter Code**. This allows the user to gain access to the menu when the unit is locked. Press the \uparrow key to increment each digit. Press the \leftarrow key to step to the next digit to the left. Press the **E** key to enter the displayed code.

Record this number for later use!

LOCK UNIT: (lock unit) Sets the panel lock ON or OFF. Press the \uparrow key to select On or OFF. Press the **E** key to enter the displayed selection.

Programming Flowchart

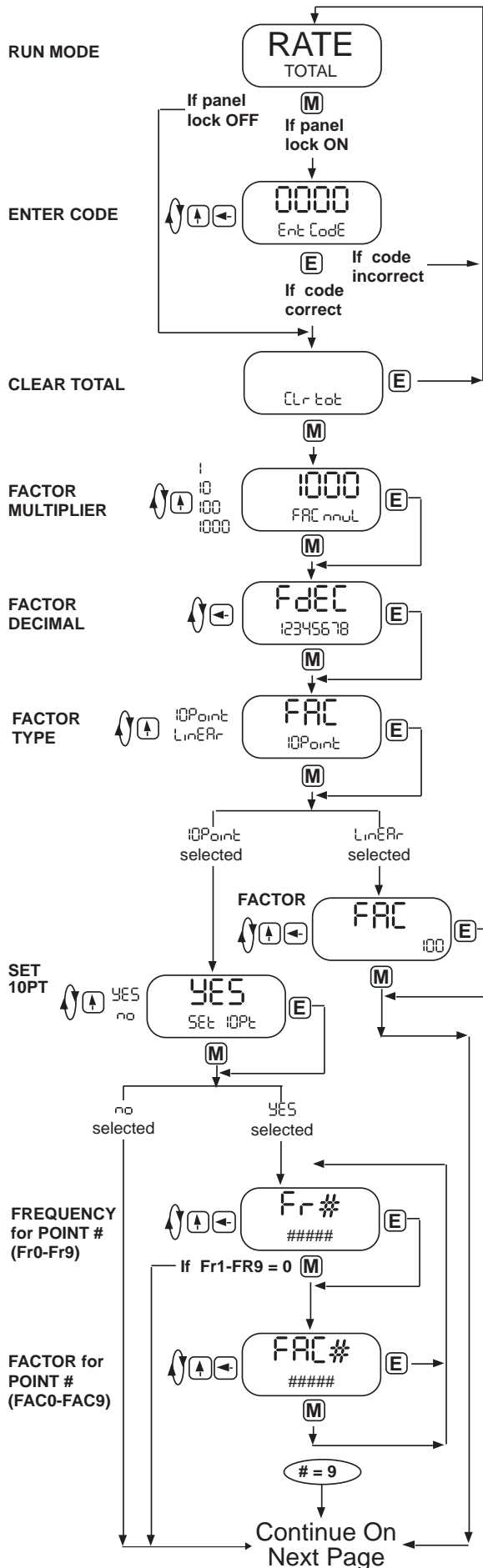

Press the **M** key to enter the programming menu.

If the panel lock is on, you must enter the 4 digit lock code to gain access to the menu.

Press the **↑** key to increment each individual digit of the code.

Press the **←** key to advance to the next digit.

Press the **E** key to enter the displayed code.

If the code is correct, display advances to "Clr tot", if not, display returns to run mode

Press the **E** key to clear the totalizer and return to the programming menu.
Press the **M** key to skip and go to next menu item.

Press the **↑** key to choose the factor multiplier (1, 10, 100, 1000).

Press the **E** key to enter the displayed factor multiplier.

Press the **M** key to skip and keep the existing factor multiplier.

Press the **←** key to step the factor decimal to the desired location.

Press the **E** key to enter the displayed decimal location.

Press the **M** key to skip and keep the existing location

NOTE: For best performance and resolution choose as many decimal places as possible in the K-Factor. Example: Enter a K-Factor of 1 as 1.000.

Press the **↑** key to choose factor type (iOPoint or LINEAR).

Press the **E** key to enter the displayed factor type.

Press the **M** key to skip and keep the existing factor type.

The **FAC** prompt will only appear if **LINEAR** is selected or if the unit was ordered without the 10 point linearization option.

Press the **↑** key to increment each individual digit of the factor.

Press the **←** key to advance to the next digit.

Press the **E** key to enter the displayed factor.

Press the **M** key to skip and keep the existing factor.

The **SEt 10Pt** prompt will only appear if **iOPoint** is selected. This allows users to bypass the 10 point set up and keep the existing values.

Press the **↑** key to choose YES or NO.

Press the **E** key to enter the displayed selection.

Press the **M** key to skip (same as selecting NO).

Press the **↑** key to increment each individual digit of the frequency for point #.

Press the **←** key to advance to the next digit.

Press the **E** key to enter the displayed frequency.

Press the **M** key to skip and keep the existing frequency.

Always enter "0" for Fr0. If "0" is entered for any other Fr#, the display will advance to the next prompt (tdec).

Press the **↑** key to increment each individual digit of the factor for point #.

Press the **←** key to advance to the next digit.

Press the **E** key to enter the displayed factor.

Press the **M** key to skip and keep the existing factor.

Programming Flowchart

(continued)

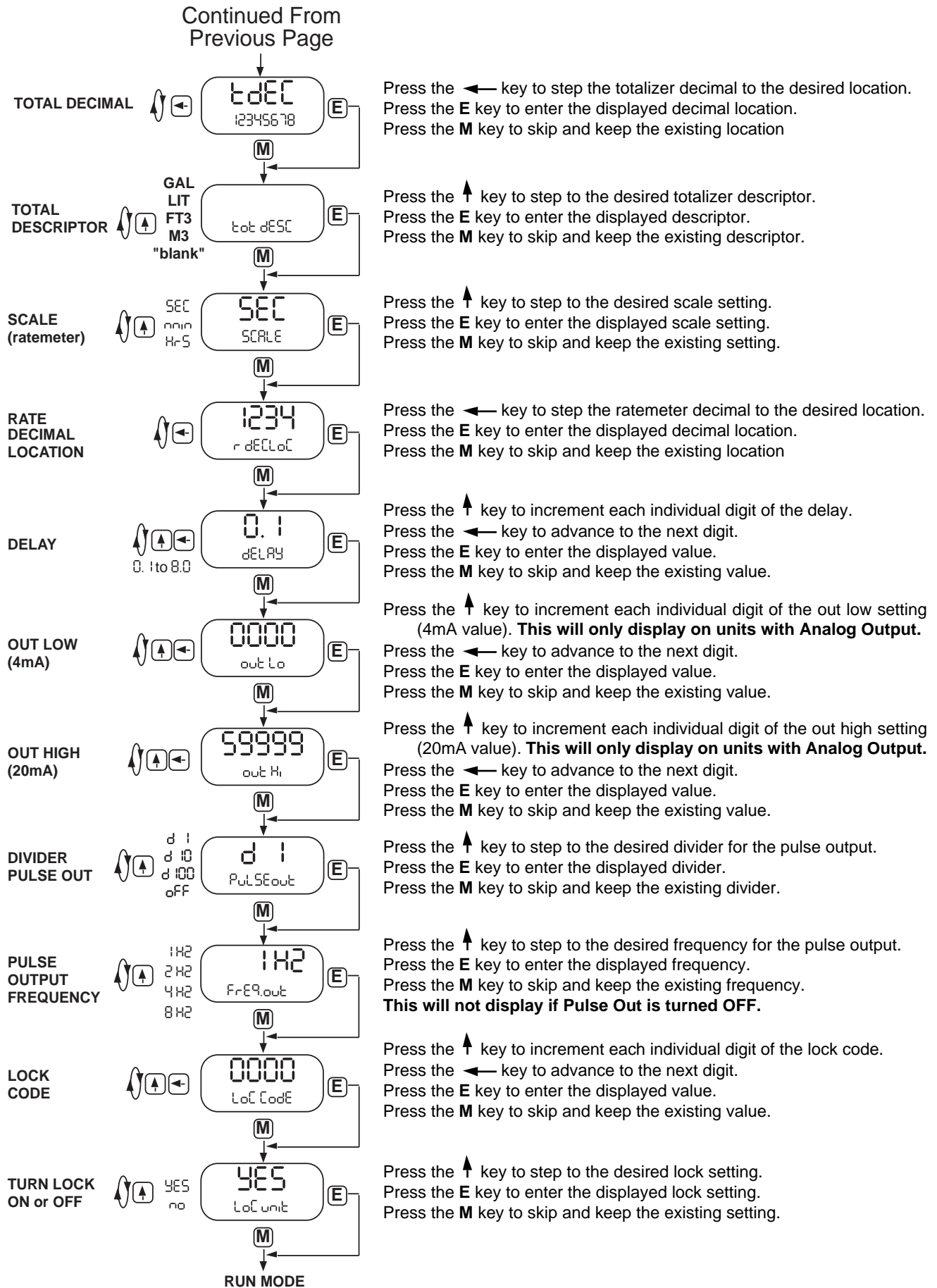

Operation

A suitable pulse producing device or flow meter is wired to one of the three pulse inputs provided on the PC58. Only one of these inputs is used in a given application. There are no connections to the two unused pulse inputs.

Isolated magnetic pickups may be connected to terminals 1 and 2. Isolated contact closures may be connected to terminals 5 and 6. Any pulse type may be connected to terminals 9(-) and 10(+).

Power to the unit may be provided by internal batteries, external DC, or the current loop. In all cases, the internal battery will provide for continued operation in the event primary power is lost.

Once properly wired, the operation of the PC58 is automatic.

The flow totalizer is updated every 2 seconds* with the latest total. If no input counts are received the unit remains in a low power state to conserve power.

The flow total may be cleared by the front panel switch sequence or by a contact closure on the remote reset terminal to circuit common.

To reset the unit from the front panel, the following key sequence is required:

- Press **M** "CLr tot" will be displayed (if the panel lock is on, the display will prompt "Ent Code".
Enter the proper code to advance to the CLr tot prompt)
- Press **E** To clear the total. Unit will return to operation

The flow rate indicator will measure the flow rate once every 2 seconds* and display the flow rate.

If the input pulses are not detected within the delay setting (0.1 to 8.0 seconds), a flow rate of 0 will be indicated.

The analog output will be scaled based on the user selected zero and full scale and the measured flow rate. The analog output is updated every 2 seconds*.

The pulse output will generate a burst of pulses every 2 seconds* in accordance with the instrument setup of pulse scaling.

* A large delay setting and internal math operations may delay the update rate.

Maintenance:

The only scheduled maintenance for the PC58 is periodic replacement of the battery.

Battery Replacement:

The PC58 has a battery monitor feature which illuminates when the lithium battery voltage approaches its end of life. A descriptor, "BAT", illuminates when the battery voltage falls below this predetermined value. The low battery detector operates correctly with all power options.

The battery, or batteries, should be replaced within several weeks of the first occurrence of low battery warning, "BAT". Left unattended, the unit may become inaccurate, cease to operate or lose setup information or malfunction.

Batteries should be replaced one at a time to avoid interrupting the power.

See INSTALLATION section for battery installation instructions.

Error Messages

The PC58 is provided with extensive self checking which assists the user in the location of setup entry errors and in reporting malfunctions or unusual operating conditions. When an error occurs, the display will flash. Press any key to see the error message corresponding to the error that has occurred. Press any key again to acknowledge the error. (If the error can be eliminated by a change of setup values, the unit will automatically advance to the MENU so that the appropriate setup changes can be made).

Table - 2 illustrates the warning message, problem, and recommended corrective actions.

Diagnostic Error Messages Table-2

WARNING MESSAGE	CAUSE	CORRECTIVE ACTION
Rate Error	Rate Low set higher than Rate Hi	Set Rate Hi greater than Rate Lo
FAC Error	Factor = 0	Set in correct Factor
"BAT" Descriptor	Low Battery	Replace battery(ies)
Total	Total rollover	None required
Rate	Rate exceeds 59999	Use lower rate dec point
PULSE	Pulse out Overflow	Use different pulse scaler or totalizer decimal point

Analog Output Calibration

Full Scale Adjust:

The 4-20 mA has been accurately set to 20.000 mA by the factory. No adjustments should be required.

The 4-20 mA output may be verified periodically by installing a digital milliamp meter in series with the analog output and simulating a full scale or over range flow rate.

The Full scale adjustments may be trimmed to 20.000 mA +/- .020 mA if required. To adjust, locate the span adjust potentiometer mounted on component side of PCB, above the display to the left (rear view). Turn clockwise to increase the current output, counter-clockwise to reduce.

The 4 mA is set automatically.

Model Number

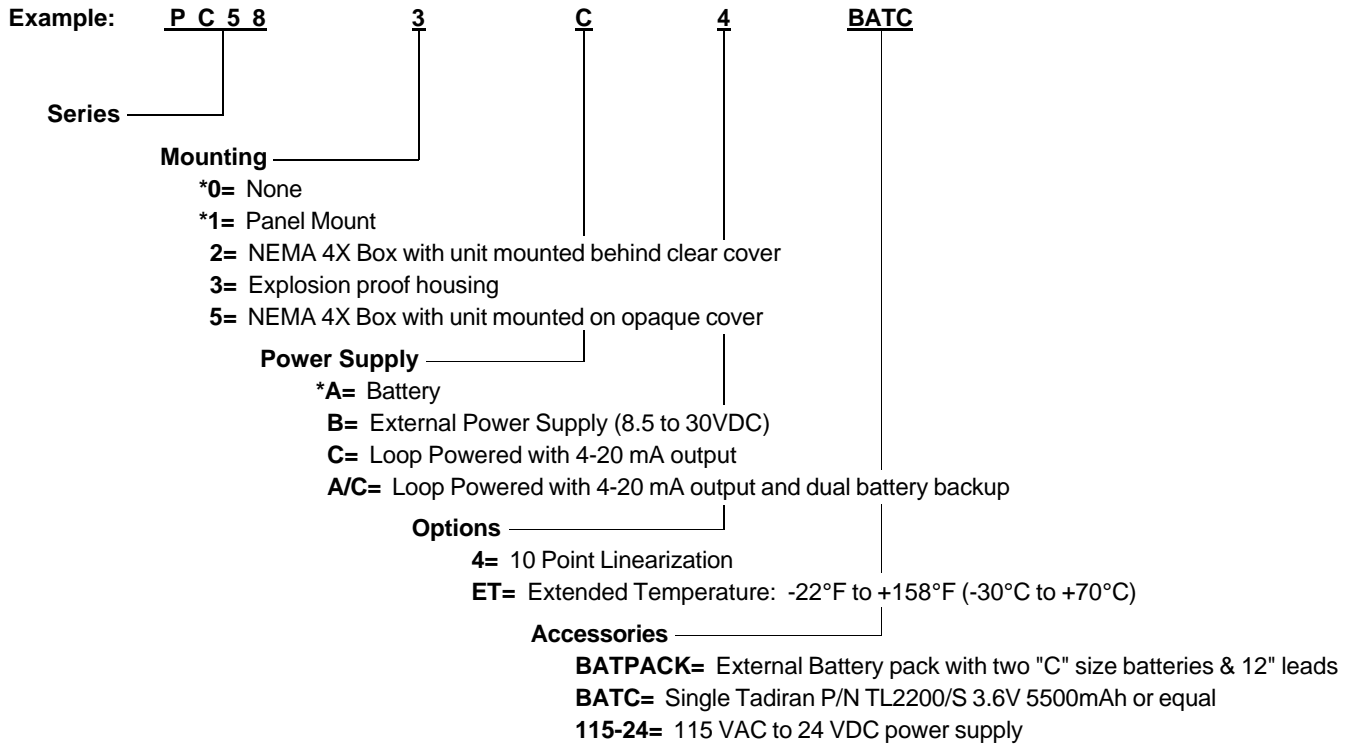

* External battery pack supplied with models PC580A & PC581A

Warranty

Tuthill Transfer Systems ("Manufacturer") warrants to each buyer of its FPP Meters products (the "Buyer") for a period of 12 months from date of invoice or sales receipt, but in no event more than 18 months from date of manufacture, that goods of its manufacture ("Goods") will be free from defects of material and workmanship. Manufacturer's sole obligation under the foregoing warranties will be limited to either, at Manufacturers' option, replacing or repairing defective Goods (subject to limitations hereinafter provided) or refunding the purchase price for such Goods theretofore paid by the Buyer, and Buyer's exclusive remedy for breach of any such warranties will be enforcement of such obligations of Manufacturer. If Manufacturer so requests the return of the Goods, the Goods will be redelivered to Manufacturer in accordance with Manufacturer's instructions F.O.B. Factory. The remedies contained herein shall constitute the sole recourse of the Buyer against Manufacturer for breach of warranty. IN NO EVENT SHALL MANUFACTURER'S LIABILITY ON ANY

CLAIM FOR DAMAGES ARISING OUT OF THE MANUFACTURE SALE, DELIVERY OR USE OF THE GOODS EXCEED THE PURCHASE PRICE OF THE GOODS. The foregoing warranties will not extend to Goods subjected to misuse, neglect, accident or improper installation or maintenance, or which have been altered or repaired by anyone other than Manufacturer or its authorized representative. THE FOREGOING WARRANTIES ARE EXCLUSIVE AND IN LIEU OF ALL OTHER WARRANTIES OF MERCHANTABILITY, FITNESS FOR PURPOSE OF ANY OTHER TYPE, WHETHER EXPRESS OR IMPLIED. No person may vary the foregoing warranties and remedies except in writing signed by a duly authorized officer of Manufacturer. Warranties or remedies that differ from the foregoing shall not otherwise be binding on Manufacturer. The Buyer's acceptance of delivery of the Goods constitutes acceptance of the foregoing warranties and remedies, and all conditions and limitations thereof.



TUTHILL
Transfer Systems

48513 Highway 51 North P.O. Box 400
Tickfaw, Louisiana USA 70466
Tel 504 542-5200 Fax 504 542-7394

www.tuthill.com

METER SENSOR

PC58
REED SWITCH SENSOR
4-20 MA OUTPUT LOOP

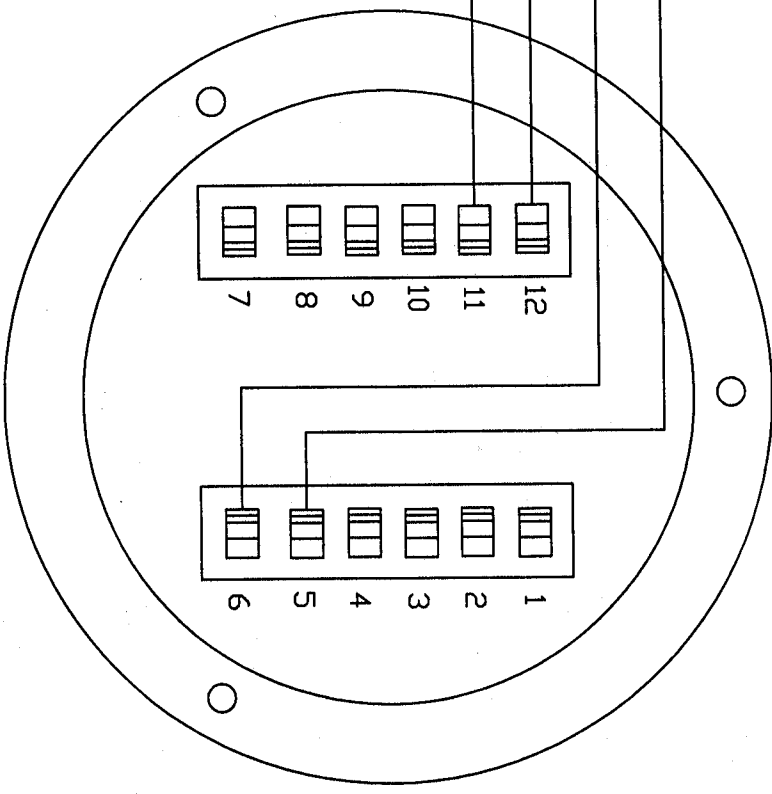
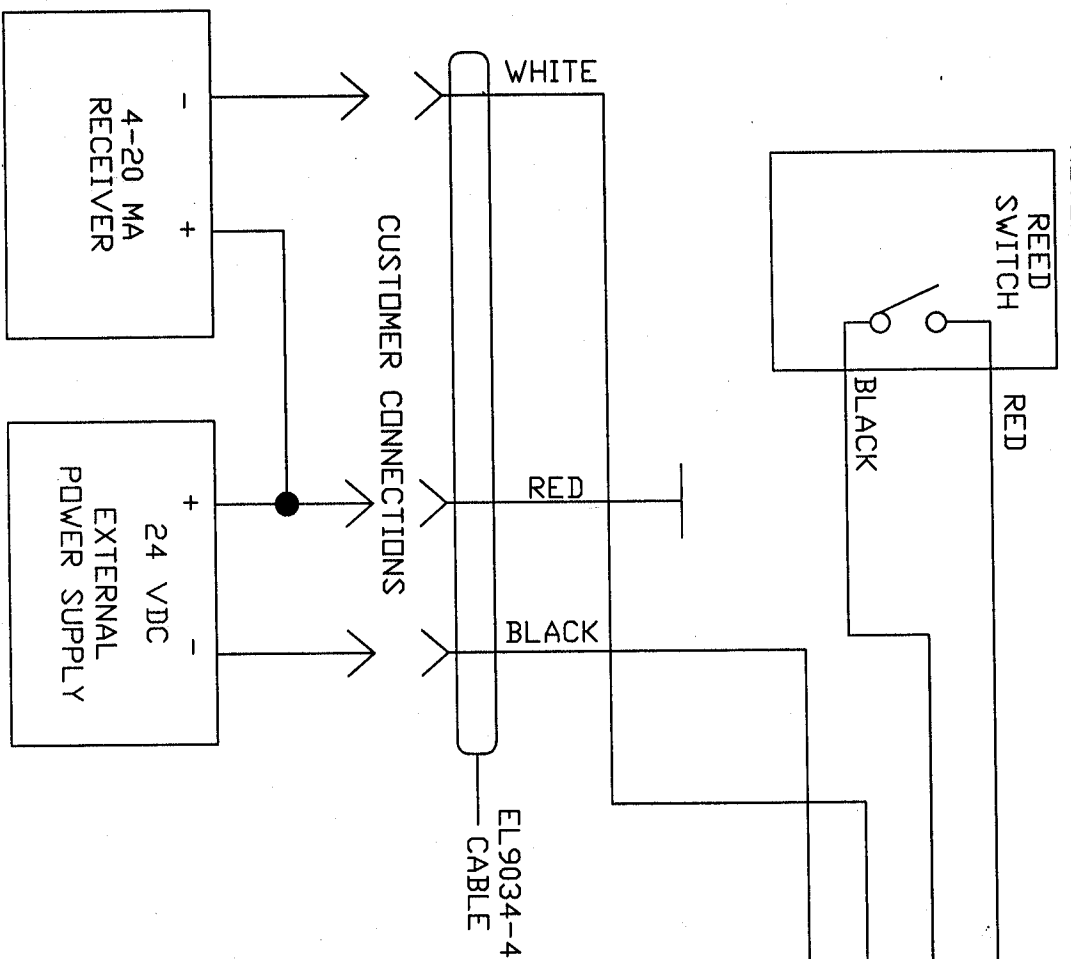

- 1. Mag Input 1
- 2. Mag Input 2
- 3. Shield/GND
- 4. Reset Input
- 5. Contact Input
- 6. Common/ DC In (-)
- 7. Dpto Out (-)
- 8. Dpto Out (+)
- 9. Dpto Input (-)
- 10. Dpto Input (+)
- 11. 4-20mA (-)
- 12. 4-20mA (+)/DC In (+)

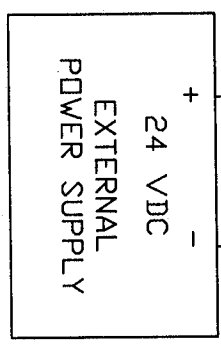

USE WITH EL2501

LET. ECN	REVISION	DATE
A	N/A	12/18/01
	RELEASE	

THIS DRAWING WAS MADE ON THE CAD/CAM SYSTEM CHANGES & ADDITIONS ARE TO BE MADE ONLY ON THE SYSTEM. THIS DRAWING IN DESIGN AND DETAIL IS OUR PROPERTY AND MUST NOT BE USED EXCEPT IN CONNECTION WITH OUR WORK. IT SHALL NOT BE REPRODUCED AND SHALL BE RETURNED TO US ON DEMAND. ALL RIGHTS RESERVED.

ALL DIMENSIONS IN INCHES UNLESS OTHERWISE NOTED

XXXX +/- .010
XXXXX +/- .005
ANGULAR +/- .5°

BREAK ALL SHARP CORNERS
CHAMFER ALL TAP DRILLED HOLES
MATERIAL FINISH

TUTHILL
Transfer Systems

NAME REED SWITCH W/ PC58/ EL2501

DRN BY JAB

APPR. BY VE

SCALE NTS

DATE 12/18/01

EXP. #

DRG. # RS/PC58/2501

REV. A