

TOTAL CONTROL SYSTEMS

"The Standard of Measurement"

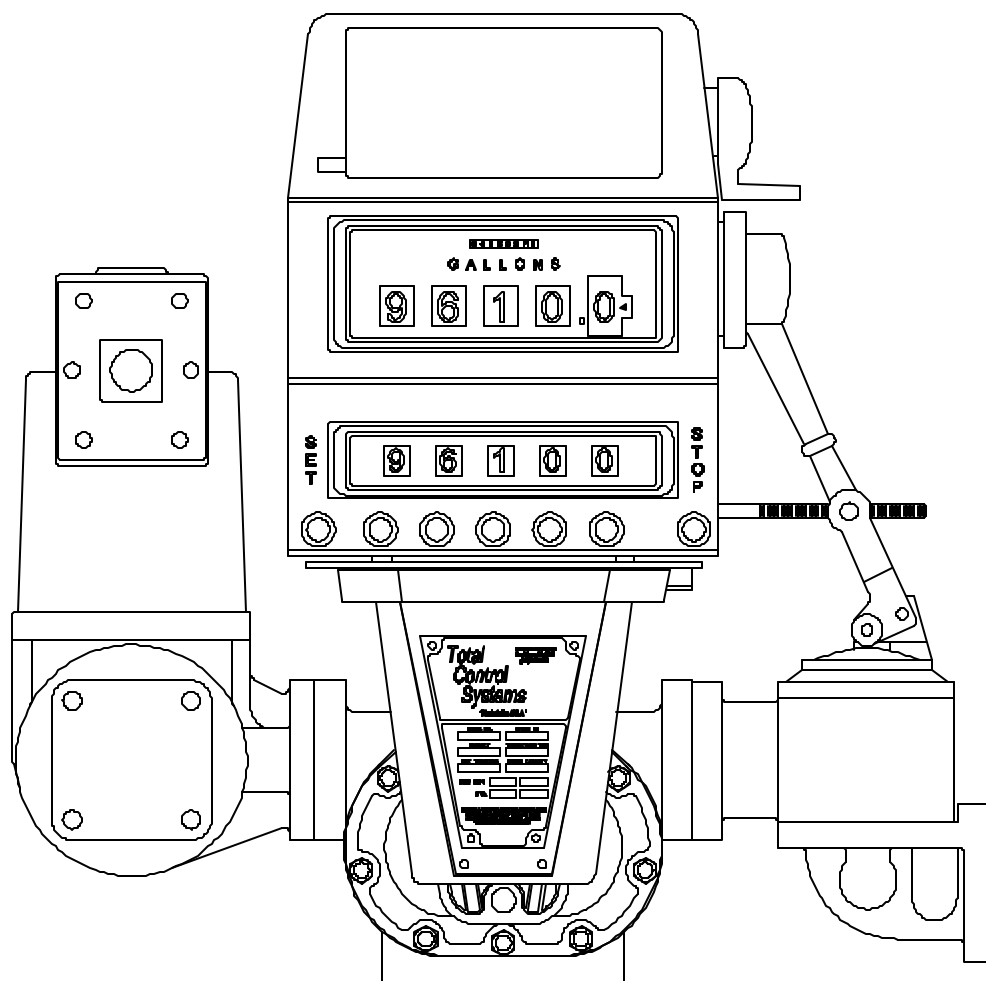

700-15 Rotary Flow Meter SERVICE MANUAL*

* For 700 meters with serial numbers 700000 or higher

TOTAL CONTROL SYSTEMS
2515 Charleston Place • Fort Wayne, IN 46808
Toll Free: (800) 348-4753 • Tel: (260) 484-0382 • Fax: (260) 484-9230
E-mail: sales@tcsimeters.com • Website: www.tcsimeters.com

SPECIFICATIONS FOR MODEL 700-15

Flange Connection:	1-1/2" NPT Flange Connection, 2" NPT Flange Optional BSPT, Slip Weld or ANSI flanges available upon request.
Flow Rate:	Up to 60 GPM (227 LPM);
Maximum Pressure:	150 PSI (10.5 BAR)
Working Temperature:	-20°F to 160°F (-28.9°C to 71°C);

METER TYPES

SP	Standard Petroleum	Refined products: Gasoline, Fuel Oil, Aviation Fuels, Kerosene, Lubricating Oils, Vegetable Oils, etc.
IP	Industrial Products	Refined products, Solvents and Industrial Chemicals

MATERIAL OF CONSTRUCTION

Type	Housing	Rotors	Journals	Bearings	Bearing Plates	Timing Gears	Seals
SP	Anodized Aluminum	Anodized Aluminum	Hardchrome SS	SS Alloy	316 SS	316 SS	Viton®
IP	Hardcoat Anodized Aluminum	Hardcoat Anodized Aluminum	Hardchrome SS	SS Alloy*	316 SS	316 SS	Kalrez® & Teflon®

* Ceramic Bearings are available upon request.

Viton® is a registered trademark of E.I. DuPont de Nemours & Co.
Teflon® and Kalrez® are registered trademarks of Dupont Dow Elastomers, L.L.C.

700 ROTARY METER OPERATION

The TCS Model 700 series flow meter is a simple and efficient design. The meter consists of a single fluid chamber that contains a single blocking rotor and two displacement rotors whose rotation is synchronized with mating gears. As the fluid enters the fluid chamber, the blocking rotor is forced to rotate. The displacement rotors, also rotating in conjunction with the blocking rotor help direct the fluid flow through the chamber and to the outlet. The linear flow of the fluid is thus translated into rotary motion in the meter. The output of the meter is picked up from the rotation of the blocking rotor and transmitted to a register or pulse transmitter.

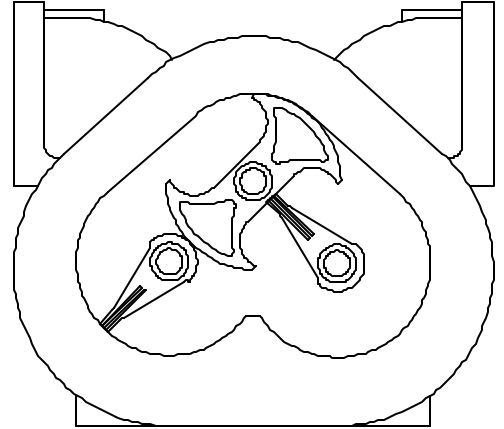

The rotors in the meter are designed to operate at close tolerances to one another and the wall of the fluid chamber. There are slight gaps between the rotors and the chamber wall. Because of this, it is important that the meter be properly applied for the flow rate and operating pressure of the system.

Because the fluid flow through the meter is redirected only slightly from its natural flow, there is very little pressure drop across the meter, unlike other meters that use multiple measuring chambers.

The meter design uses high quality long life materials for the rotor bearings and journals. Since there is no contact between the rotors and the fluid chamber wall, these critical components have a long life expectancy.

Calibration of the meter involves adjusting the rotation of the output shaft relative to the rotation of the internal rotors of the meter. This is accomplished by changing the settings on an adjuster device. Calibration of the meter is discussed in detail in the section Meter Calibration on page 5.

ACCURACY

The TCS model 700 series flow meter holds the National Type Evaluation Program (NTEP) Certificate of Conformance meeting the National Institute of Standards and Technology (NIST) Handbook 44 requirements. The TCS model 700 series flow meter combines outstanding accuracy with superior performance. At constant flow, with all other conditions being constant, the flow meter does not vary more than $\pm 0.02\%$ in repeatability. Due to the smooth flowing characteristics of this meter design, the minimum seal area provides a sustained accuracy over a wide range of flow and accuracy regardless of pressure.

METER APPLICATION

When installing a meter into a system, several factors must be considered.

Flow Rate

The flow rate of the system must be within the meter's capability. The 700-15 meter can operate up to 60 GPM (227 LPM). The flow rate of the system is dependent upon the system's pump capabilities, and the plumbing configuration, and the product to be measured. Higher flow rates can be achieved with products that have low viscosities and high lubricity (i.e. gasoline, diesel fuel, aviation fuels).

Operating Pressure

The 700-15 meter can operate at pressures up to 150 PSI (10.5 BAR).

Compatibility

Products with suspended solids in them will score the meter body and rotors due to the tight clearances within the meter's measuring chamber. The liquid to be metered must also be compatible with the meter. Contact factory on receiving the Chemical Compatibility Chart for more information. *Note TCS recommends that the 700-15 meter should have limited use on water applications. Water has no lubricity and will drastically shorten the meter's service life. It is recommended that if the meter is to be used on water, it should be derated about 40 to 50 percent of flow and **NOT** on continuous duty applications.*

Operating Temperature

The temperature range of the product to be metered must be within the meter's range. The 700-15 meter can operate between -20°F and 160°F (-20°F to 160°F (-28.9°C to 71°C). Higher working temperatures can be achieved at reduced pressures (Consult factory for more information).

Registration

The 700-15 meter uses a Veeder Root mechanical 5-wheel resettable register in 1/10th U.S. gallons, with an 8-digit non-resettable totalizer. Litres, ounces, pounds or nearly any other unit of measure can be accommodated upon request. Other electronic registers are available upon request.

Weights & Measures Approved Device

Some liquids may require a measuring device to have a "Type Approval" from the National Institute of Standards and Technology (NIST) Office of Weights & Measures subsidiary National Type Evaluation Program (NTEP) Handbook 44 requirements. This "Type Approval" declares that the device has been performance tested and certified on specific liquid product class within various system factors by NIST and is thereby qualified to sell a liquid product off the measuring device. *The Total Control Systems 700 series flow meter currently has a NTEP number (99-097) for the resale of Refined Products, which include the likes of Gasoline, Diesel Fuel, Aviation Fuels, Lube Oils, Kerosene, Mineral Spirits, Motor Oils, Vegetable Oils, etc.*

INSTALLATION & START-UP RECOMMENDATIONS

Start-up instruction for new installations or after maintenance and repairs:

Best Plumbing Configuration

- System should be designed to keep the flow meter full of liquid at all times.
- Use full 1-1/2" pipe for the installation.
- The pipe should be laid out as straight as possible to reduce pressure loss from flow restriction.
- Meter inlet and outlet should be lower than the associated system plumbing (sump position).
- It is not necessary for the air eliminator to be installed bolted directly to the meter. It can be installed upstream from the meter. For effective operation of the air eliminator, it should be mounted between the meter and any valves, tees or any other potential places where air may enter the system.
- The metering system should include a means to prove meter accuracy.
- The meter and piping must be installed in such a way as to avoid accidental draining of the meter.

Slow Flooding Of System

When a pump is turned on and a valve opened in a new, dry system, tremendous pressure can be built up in the piping and forced through the meter. The high pressure and volume of air causes the meter to operate more quickly than normal. When product reaches the meter, there is an abrupt slowing of the meter rotors, which could cause damage to the register, rotor shafts, packing gear and/or blade, timing gears and other components. *The recommended method of starting any system is to flood the piping gradually. This allows product to slowly force the air from the entire system.*

When operating the meter with accessories, observe the following recommendations:

- Valves should be opened slowly to avoid a pressure surge that can damage the meter or air eliminator. System pressures should be maintained below 70 PSI.
- Strainers should be cleaned frequently.

Protection From Debris

On new installations, care must be taken to protect the meter from damage during start-up. Damage may result from the passage through the meter of welding slag or spatter, thread cuttings, rust, etc. There are several methods of protecting meters from this material including: the insertion of a spool (a flanged length of pipe equal in length to the meter and any accessories attached to the meter) in place of the meter until the system is flushed, temporarily bypassing the plumbing around the meter, or by installing a strainer ahead of the meter in the line. Once the system has run "clean" for a period of time, the meter may be reinstalled or protective devices removed.

Calibration

The meter shall be tested and calibrated when installed. Total Control Systems shall not be responsible for loss of product or any damages resulting from the end user's failure to test this meter to insure proper calibration. Improper calibration can result in incorrect measurements of fluid being delivered. It is the owner's responsibility to report this device to the local U.S. Weights and Measures officials for their inspection before the meter is put to use.

Changing the Direction of Flow:

The meter is set up at the factory for left to right flow. To change the meter to right to left flow, begin by removing the screws (#9 on the Meter Assembly Breakdown) and the adjuster cover plate (#7) on the front of the meter. Remove both the screws (#1), the drive shaft retainer (#10), the drive shaft (#3), the e-ring (#4) and the face gear (#5). Reinstall the gear on the shaft with the gear teeth facing up. Snap the e-ring back into place to hold the gear in place. Reinstall the shaft, mating the face gear with the drive gear of the packing capsule assembly. Reinstall the screw and cover plate. The meter will now be set up for right to left flow.

STORAGE INSTRUCTIONS

Short periods of non-use of the meter (a week or less) will present no problem, provided that the meter remains full of product. For long periods of non-use, such as winter storage, the following procedure is recommended. Before long term storage, a good practice is calibration of the meter to determine that it is functioning properly.

- 1) To store the meter when it is left in line, flush the system with clean water until 40-50 gallons of water have gone through the meter.
- 2) Pump a 50% anti-freeze / 50% water solution through the entire system (100% RV antifreeze may be used instead). With the pump running, shut off a valve downstream from the meter, making sure that anti-freeze solution is present at that point. Then close an upstream valve, such that the meter remains full of anti-freeze solution.
- 3) Remove the register from the meter, and lubricate the drive coupling shaft. After lubrication it, replace the register onto the meter.
- 4) When starting the system after a period of storage, rechecking the meter's calibration as detailed earlier in the service manual.

METER CALIBRATION

The procedure to change the calibration of the meter:

- 1) Check for repeatability
 - A) Run a fast (high gallons per minute) test in your prover and record how much the meter is over or under registering. Do **NOT** change the meter's calibration.
 - B) Run a slow (low gallons per minute) test and again record how much the meter is over or under registration.If the results from the fast and the slow test are the same or close to the same, the meter can be successfully calibrated. If the test results differ beyond the rated tolerance of the meter, then repairs are necessary before the meter can be calibrated.
- 2) A valve or nozzle must be at the end of the delivery hose (at the prover).
- 3) Turn on the pump and purge the system of air. Leave the pump on.
- 4) Shut off the valve at the end of the delivery hose and let the system pressurize.
- 5) Wet the prover and empty it, letting it drip for 30 seconds.
- 6) Reset the register on the meter to "0".
- 7) Fill the prover to the line marked "0".
- 8) Calculate the percentage increase or decrease of registration required. For example, if a 50 gallon test prover indicates exactly 50 gallons have been run through the meter against a meter registration of 49.7 gallons, the percentage increase of registration would be 0.6%. ($3/10$'s in 50 gallons is 0.6%). If meter registration is less than the test prover measured volume, an increase adjustment is required. If meter registration is greater than the test prover measured volume, a decrease adjustment is required.
- 9) Remove the seal and seal wire.
- 10) Remove the front cover plate.
- 11) Loosen the screw on the clamping ring. The adjuster barrel will now be free to rotate.
- 12) Each small hash mark corresponds to 0.02% adjustment. Each of the larger numbers on the rotating barrel corresponds to 0.1%. The large numbers engraved into the adjuster body correspond to 1%. The entire range of adjustment is 5%, with the meter being set at the factory very close to the middle of this range.
- 13) To increase the registered volume, rotate the adjuster barrel to the left by the percentage increase desired. It is recommended that the barrel be rotated 0.02% more than the desired amount and then backed down to the desired figure. This accounts for any slack present in the adjuster mechanism. In the example above, the barrel would be rotated 16 tick marks on the barrel ($15 \text{ tick marks} \times 0.02 = 0.3 = 3/10$'s plus the one tick mark for slack). With the slack removed, the barrel would then be rotated one tick mark back to the right to achieve the final adjustment.
- 14) To decrease the registered volume, the adjuster barrel is rotated to the right.
- 15) Tighten the screw and clamping ring.
- 16) Run another test and adjust if necessary.
- 17) When calibration is achieved, ensure that the screw and clamping ring are tight, then replace the cover plate.

METER TROUBLE SHOOTING

PROBLEM: Leaking packing gland and/or housing

Two common causes of packing gland leakage are thermal expansion and hydraulic shock. If two valves in a piping system (on either side of the meter) are closed at one time, and if the temperature rises as little as 1°F in the system, it could result in a rise in pressure within the system that would exceed the working pressure rating of the meter. To avoid this hazard caused by thermal expansion, a pressure-relief valve of some kind must be installed in the system.

Hydraulic shock occurs when a large volume (mass) of liquid is moving through a pipe line at some flow rate and a valve is suddenly closed. When the flow is so stopped, the entire mass of the liquid in the piping system acts as a battering ram, causing a shock effect within the meter. The greater the mass, length of line and/or velocity, the greater the hydraulic shock. Since the valve is usually located at the meter outlet, the meter housing, packing gland and the meter internal members receive the full impact of such hydraulic shock. To prevent this hazard a slow closing two-stage valve should be used with the meter. On those systems where mass, length of line, etc. are of such magnitude as to preclude the elimination of hydraulic shock with the use of a two-stage slow closing valve an impact-absorbing air cushioning device should be used.

O-Ring has been damaged or cover bolts have not been tightened enough.

PROBLEM: Product flows through meter but register does not operate.

- A) Gear train motion interrupted by non-functioning gear due to broken pin or key. Replace pin or key where required.
- B) If all meter parts are moving then problem is in register.
- C) Remove register from meter. If all meter parts are moving but output shaft of adjuster assembly is not, adjuster is worn and must be replaced.
- D) If totalizer numerals (small numbers) on register are recording, but the big numerals are not moving, register needs repair.

PROBLEM: Product flows through meter but register does not record correctly.

- A) Adjuster assembly not properly calibrated, See METER CALIBRATION on page 5 for more instructions.
- B) The factory installed gear train may have incorrect gearing ratio.
- C) Check register for defects.

PROBLEM: No flow through meter.

- A) Faulty non-functioning pump.
- B) Foreign matter within the system, meter or components.
- C) Meter has a broken rotor or rotor shaft.
- D) Excessive wear on timing gears or bearings.
- E) Meter “frozen” due to build-up of chemical “salts” inside metering chamber, sufficient to stop rotation or rotors.
- F) Valve not open or not functioning.

PROBLEM: Meter runs too slow.

- A) There is a flow restriction within the system. (i.e.: tees, elbows, valves, etc.)
- B) Foreign matter in system, meter or components.
- C) Product viscosity is different or has changed from what was originally known.
- D) Meter gears or rotors partially “salted” enough to slow up rotation of parts.
- E) Valve internal mechanism faulty. Valve does not open fully or the linkage is not properly adjusted.

For additional assistance, contact Total Control Systems Service Department at 1-800-348-4753.

KEY FEATURES OF 700 METER

TYPICAL ACCURACY CURVE

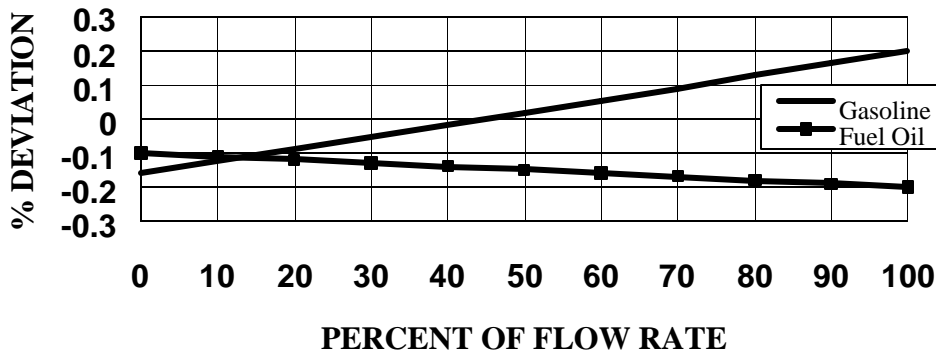

The 700 meter's accuracy (percent of error over or under the zero – error level) remains within design parameters ($\pm 0.2\%$) over its 5 to 60 GPM flow range. This exceeds the maintenance requirements for accurate custody transfer of product, as specified in the National Institute of Standards and Technology (NIST) Handbook 44.

PRESSURE DROP CURVE 32 SSU SOLVENT

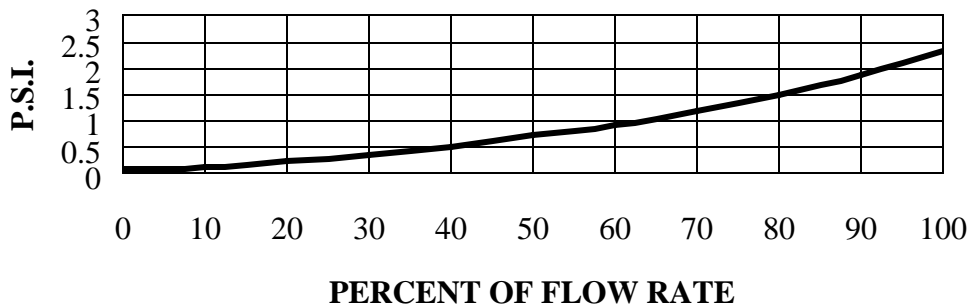

The 700-15 meter is mechanically capable of accurately metering products from 5 to 60 GPM. Comparing lowest and highest flow rates results in a 12:1 turn down ratio for the 700-15 meter. The nameplate on the 700-15 meter states the flow range as 10 – 60 GPM. This matches the flow range across which the meter was tested while earning a Certificate of Conformance from the National Type Evaluation Program (NTEP). It should be noted that as viscosity increases, maximum flow rate may decrease. Viscosity is a measure of the flowability of a product.

DIMENSIONS

700-15

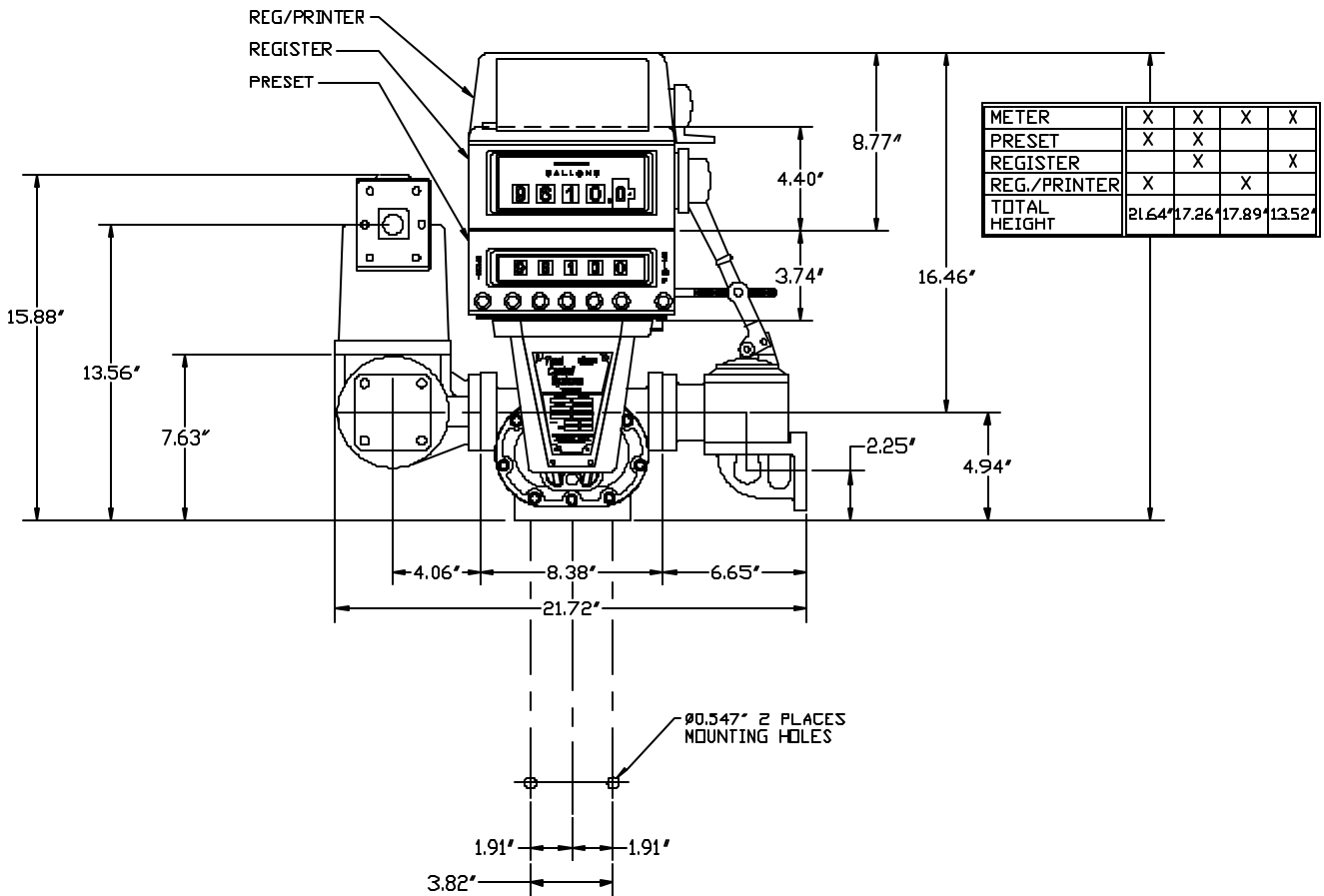
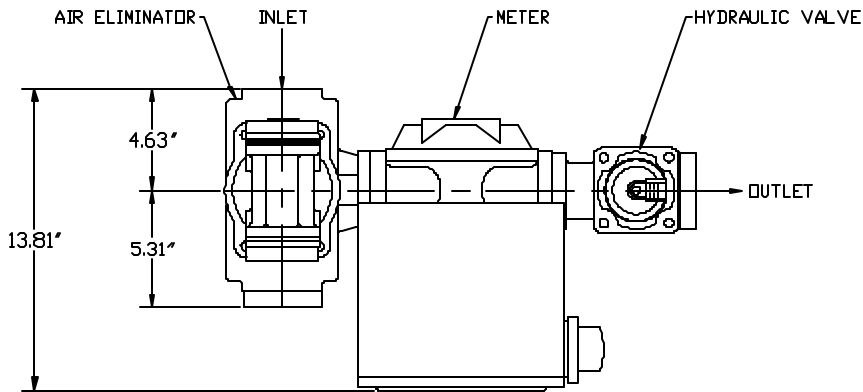

Measurements are in Inches.

METER ASSEMBLY
700-15

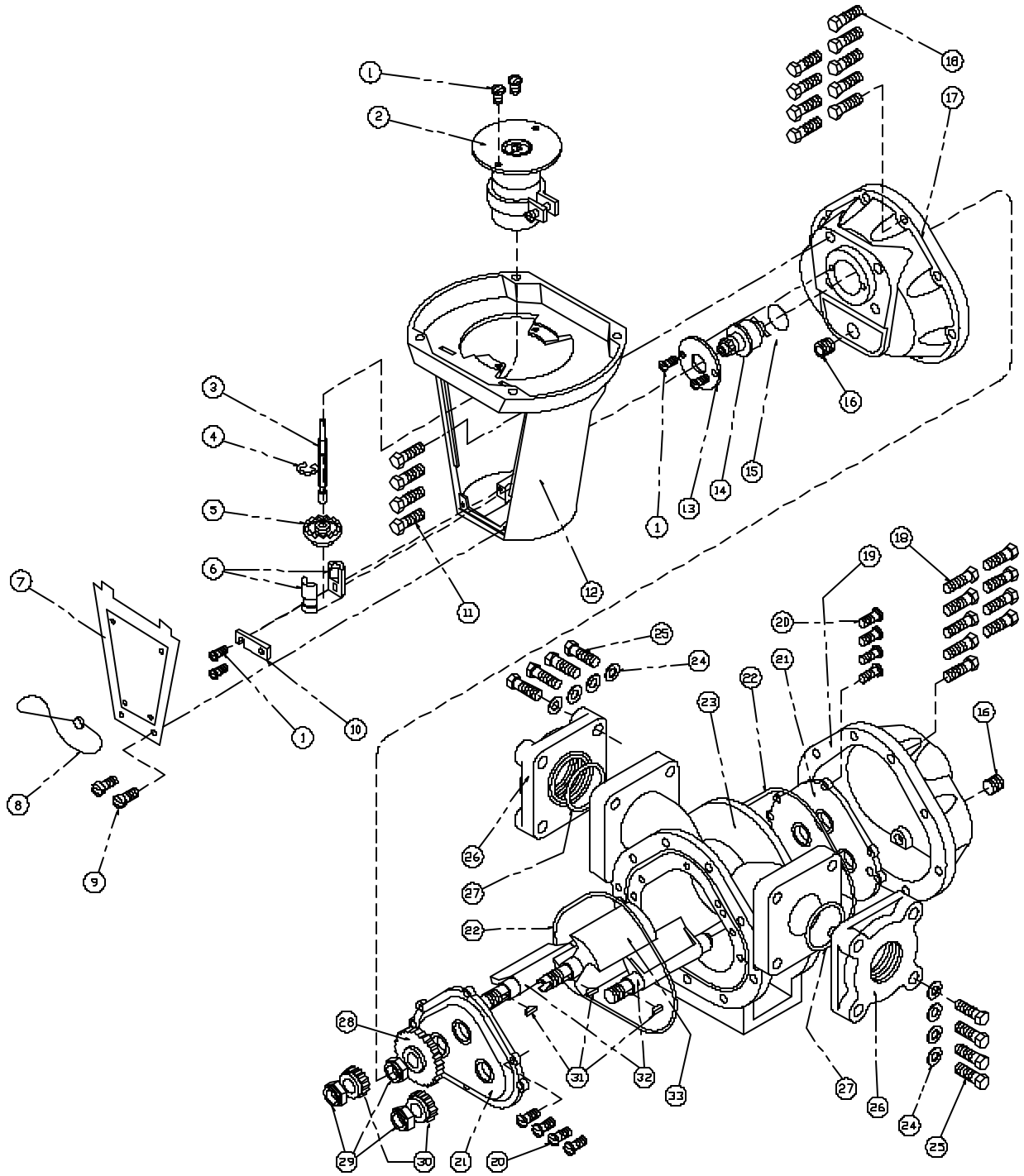

METER ASSEMBLY
700-15

ITEM #	DESCRIPTION	QTY	700-15SP	700-15IP
1	Round Head Screw	6	1-128279	1-128279
2	Adjuster Assembly	1	700100	700100
3	Drive Shaft	1	700019	700019
4	E-Ring	1	700016	700016
5	Face Gear	1	700037	700037
6	Bushing	2	700020	700020
7	Adjuster Cover Plate	1	700017	700017
8	Seal Wire	1	1-118849	1-118849
9	Drilled Head Screw	2	700042	700042
10	Drive Shaft Retainer	1	700022	700022
11	Head Mount Screw	4	700040	700040
12	Register Support	1	700200	700200
13	Packing Retaining Plate	1	700015	700015
14	Packing Capsule Assembly, 4:1	1	700160	700160
15	O-ring, Packing	1	700009	700010
16	Plug, 3/8"	2	700024	700024
17	Cover, Front	1	701500	701500
18	Cap Screw	18	701016	701016
19	Cover, Rear	1	701550	701550
20	Round Head Screw	8	702014	702014
21	Bearing Plate	2	701205	701215
22	O-ring, Cover	2	701001	701002
23	Housing	1	701110	701115
24	Flat Washer	8	702018	702018
25	Cap Screw	8	702017	702017
26	Flange	2	701600	701600
27	O-ring, Flange	2	701012	701013
28	Gear, Blocking Rotor	1	701350	701350
29	Rotor Lock Nut	3	701010	701010
30	Gear, Displacement Rotor	2	701450	701450
31	Rotor Key	3	701008	701008
32	Rotor, Displacement	2	701405	701410
33	Rotor, Blocking	1	701305	701310

AIR ELIMINATOR AND STRAINER ASSEMBLY

740-15

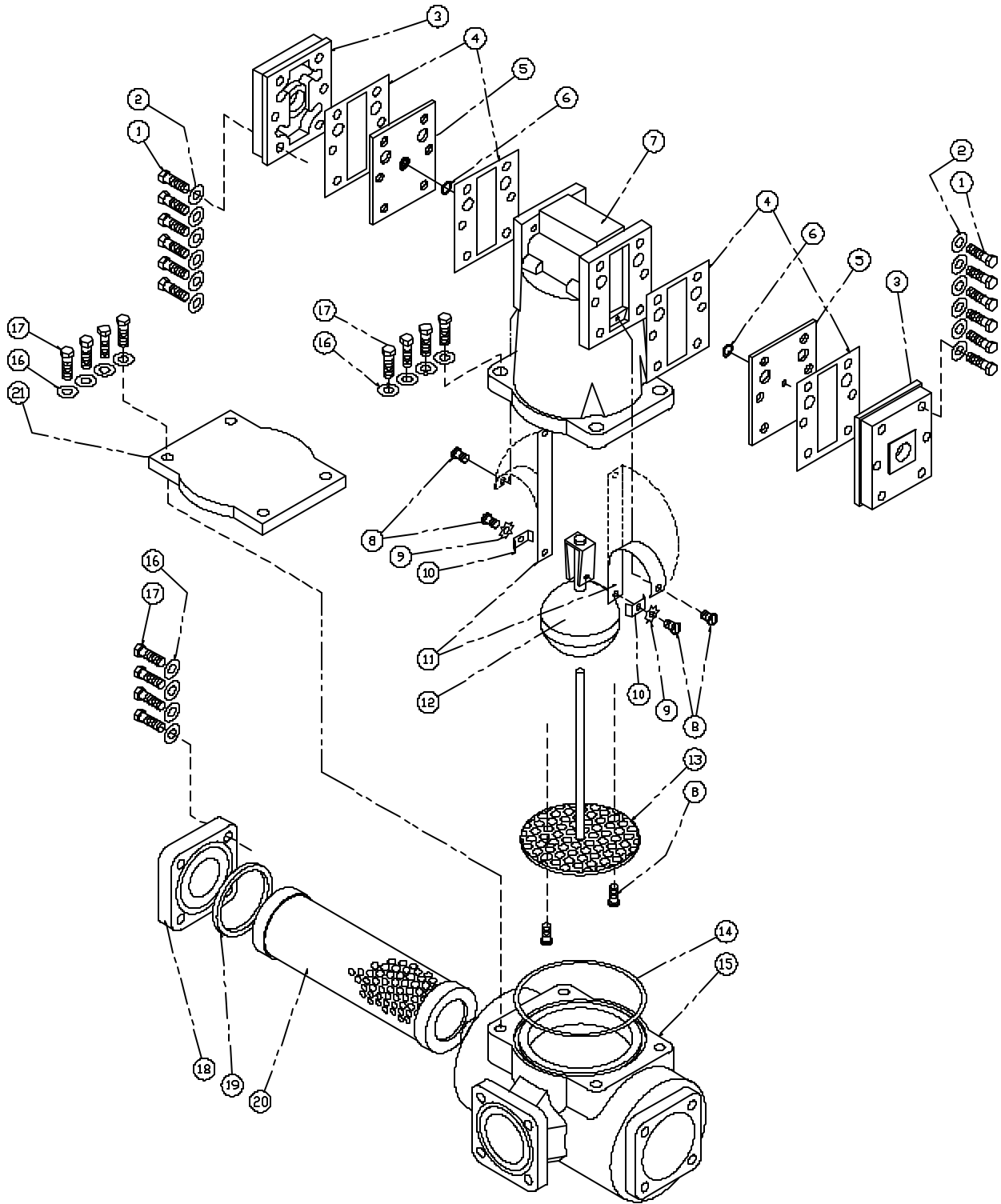

AIR ELIMINATOR AND STRAINER ASSEMBLY
740-15

ITEM #	DESCRIPTION	QTY	740-15SP	740-15IP
1	Cap Screw	12	740050	740050
2	Ring Washer	12	740051	740051
3	Outlet Cover	2	740010	740010
4	Plate Seal	4	740005	740004
5	Valve Plate	2	740038	740006
6	O-ring	2	740036	740037
7	Air Eliminator Housing	1	740020	740020
8	Screw	6	740030	740030
9	Split Lock Washer	2	740017	740017
10	Retaining Clip	2	740012	740012
11	Reed Valve	2	740007	740007
12	Float Assembly	1	740013	740013
13	Diffuser and Shaft Assembly	1	740035	740035
14	Top Seal O-ring	1	740009	740019
15	Strainer Housing	1	742020	742020
16	Ring Washer	8	702018	702018
17	Cap Screw	8	701017	701017
18	Basket Cover	1	742050	742050
19	Seal Ring	1	742003	742004
20	Strainer Basket	1	742010*	742005**
21	Strainer Cover, Optional	1	740041	740041

* SP strainers are standard with 40 mesh screens; other sizes are available upon request.

** IP strainers are standard with 0.050 perforated screens; other sizes are available upon request.

HYDRAULIC VALVE ASSEMBLY 750-15

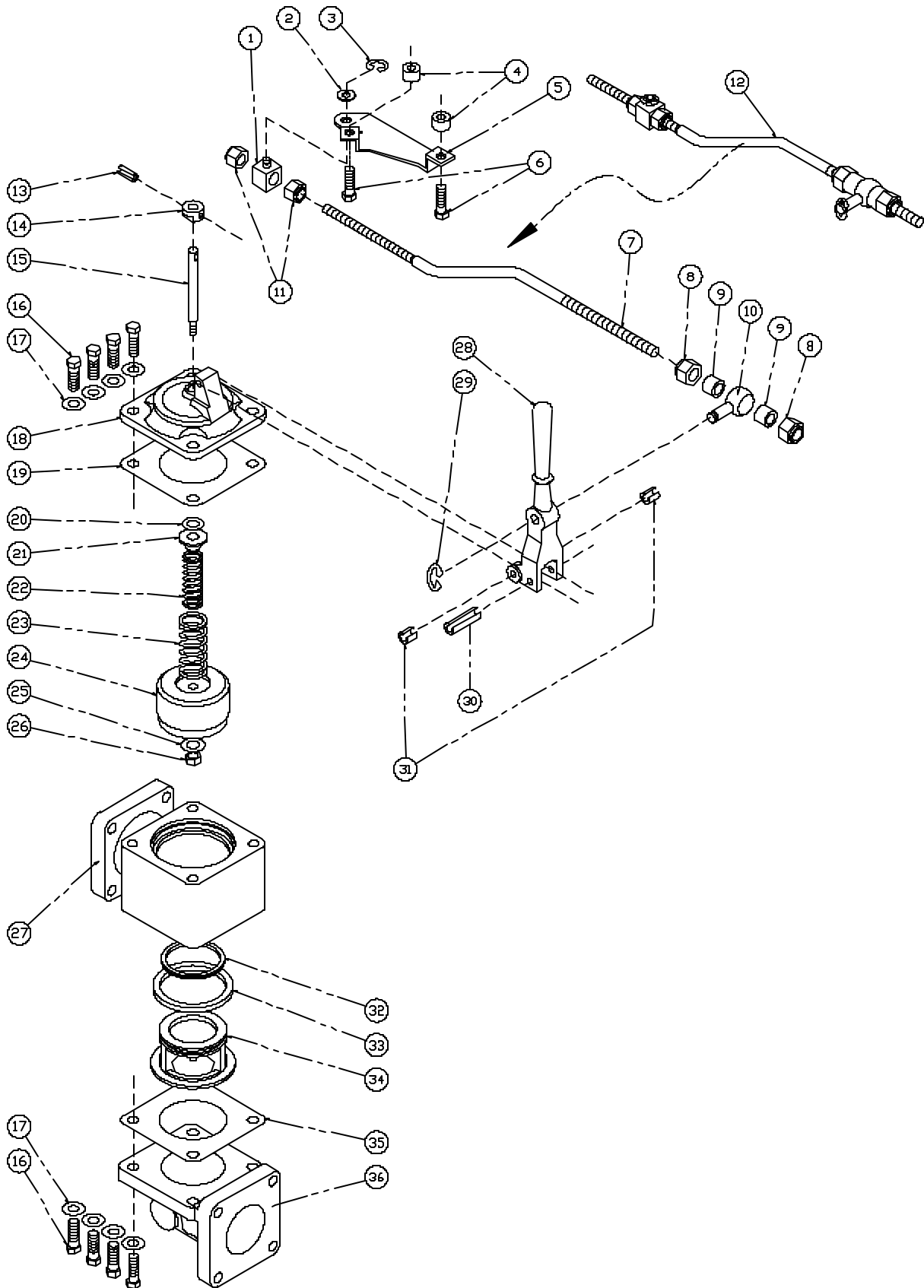

HYDRAULIC VALVE ASSEMBLY
750-15

ITEM #	DESCRIPTION	QTY	750-15SP	750-15IP
1	Linkage Swivel Block	1	1-128140	1-128140
2	Linkage Washer	1	65034	65034
3	Linkage Retaining Ring	1	6-052482	6-052482
4	Linkage Spacer	2	1-130852	1-130852
5	Linkage Bracket	1	1-226102	1-226102
6	Linkage Screw	2	65005	65005
7	Linkage Arm	1	752001	752001
8	Linkage Lock Nut	2	750001	750001
9	Linkage Sleeve	2	750002	750002
10	Linkage Spherical Pivot	1	750003	750003
11	Linkage Lock Nut	2	65008	65008
12	Linkage Assembly Kit	1	752001KT	752001KT
13	Roll Pin	1	752007	752007
14	Bushing	1	752006	752006
15	Valve Shaft	1	752008	752008
16	Screw	8	701017	701017
17	Washer	8	702018	702018
18	Valve Cap	1	752015	752015
19	Cap Gasket	1	752009	752009
20	O-ring	1	752011	752012
21	O-ring Retainer	1	752013	752013
22	Internal Spring	1	752019	752019
23	External Spring	1	752014	752014
24	Piston	1	752020	752020
25	Washer	1	752023	752023
26	Lock Nut	1	752024	752024
27	Valve Body	1	752040	752040
28	Operating Lever	1	752010	752010
29	Linkage E-ring	1	750004	750004
30	Roll Pin	1	752004	752004
31	Roll Pin	2	752005	752005
32	Upper Seal	1	752035	752036
33	Seal	1	752033	752034
34	Piston Guide	1	752030	752031
35	Elbow Gasket	1	752029	752029
36	Elbow	1	752025	752025

WARRANTY

New 700 rotary meters, equipment or components manufactured by Total Control Systems, a division of Murray Equipment, Inc. (TCS) with which this warranty is enclosed, are warranted by TCS to the original purchaser only for a period of TWELVE (12) months from installation or EIGHTEEN (18) months from the date of shipment, to be free, under normal use and service, from defects in material and workmanship. Defects occurring within the stated warranty period, TCS will repair or replace, at TCS's option; provided that part or parts are returned to TCS transportation charges prepaid, and TCS's examination discloses the parts or workmanship to have been defective upon delivery to the purchaser.

EXCLUSIONS

This warranty does not cover any parts or equipment not manufactured by TCS or related companies. This warranty does not extend to any equipment that has been altered in any way, subjected to misuse, negligence, accident, or if operated in any manner other than in accordance with TCS's operating instructions or have been operated under conditions more severe than, or otherwise exceeding those set forth in the specifications. General maintenance, calibration, clean up and normal wear is excluded from this limited warranty.

CLAIM PROCEDURES

In order to obtain performance by TCS of its obligations under this warranty, the original purchaser must obtain a Return Goods Authorization (RGA) number from TCS's customer service department within 30 days of discovery of a purported breach of warranty, but not later than the expiration of the warranty period. Once authorization is received, return the defective meter, piece of equipment, or component covered by this warranty, with transportation charges prepaid, to TCS at the address shown below together with a written statement setting forth the nature of the defect and RGA number.

REPAIR WARRANTY

All repair work is warranted for ninety (90) days from the date of shipment to customer. Some parts may be warranted for longer periods by the Original Equipment Manufacturer.

DESIGN AND EQUIPMENT CHANGES

Any changes in design or improvements added shall not create any obligation to install same on equipment previously sold or ordered.

LIMITATIONS

THERE ARE NO OTHER WARRANTIES OF ANY KIND, EXPRESS OR IMPLIED. TCS SPECIFICALLY DISCLAIMS ANY WARRANTY OR MERCHANTABILITY OR OF FITNESS FOR ANY PARTICULAR PURPOSE. TCS's sole obligation, which shall represent the buyer's sole and exclusive remedy, shall be to repair or at TCS's option, to replace any product or part determined to be defective. In no event shall TCS be liable for any special, direct, indirect, incidental, consequential or other damages of similar nature incurred by the buyer or any third party. TCS has not authorized on its behalf any representations or warranties to be made, nor any liability to be assumed except as expressly provided herein; there is no other express or implied warranty.

TOTAL CONTROL SYSTEMS

2515 Charleston Place • Fort Wayne, IN 46808

Toll Free: (800) 348-4753 • Tel: (260) 484-0382 • Fax: (260) 484-9230

E-mail: sales@tcsmeters.com • Website: www.tcsmeters.com