

General Information

WP Series turbine meters are dry-register mechanical totalizers which use a coated ductile iron body for durability. They provide a very high flow capacity with low head loss. The versatility of these meters is greatly enhanced by their sensor system, which uses built-in magnets and external slots on the register. This allows factory or field installation of low-cost reed switch sensors for a wide variety of water treatment, telemetry, and control applications. Typically, WP Turbine Meters are used for applications where the need is for both a high-accuracy non-powered flow meter (for accounting) and a field selectable output pulse for control purposes. Some of the more common applications involve:

- driving externally-paced electronic metering pumps or water treatment controls.
- Multiple switch positions
- optional factory installation of multi-pole magnets (allows for a number of different pulse rates).

Specifications

Materials

Body & Cap	Cast iron, epoxy coating
Turbine & Insert	Engineered thermoplastic
Shafts	Tungsten carbide
Bearings	Sapphire

Pressure

Up to 150 PSI working pressure

Temperature

120° F

Accuracy

±1-1/2% of reading, +/- 1% of full scale

Reed Switch

100 mA at 24V max.

Flow Range (GPM):

Size	Min. Flow	Max Cont. Flow	Max. Flow
2"	2.5	150	300
3"	2.6	400	650
4"	4.0	550	1100
6"	11.0	1000	1850
8"	18.0	1600	2850

Installation

The following installation recommendations are adapted from the American Water Works Manual M6, and will result in the best meter life and accuracy.

Piping Conditions. It is recommended that the meter be installed with at least ten diameters of straight pipe upstream and five diameters downstream from elbows, tees, crosses, valves, and other fittings. If less straight pipe is available, or if debris are likely to go through the meter, installation of a standard plate-type strainer directly upstream is recommended. If a basket-type strainer is used, it should be located at least five diameters upstream. Avoid conditions of trapped air or partially-filled pipe. This can occur when there is low flow and open discharge near to the meter.

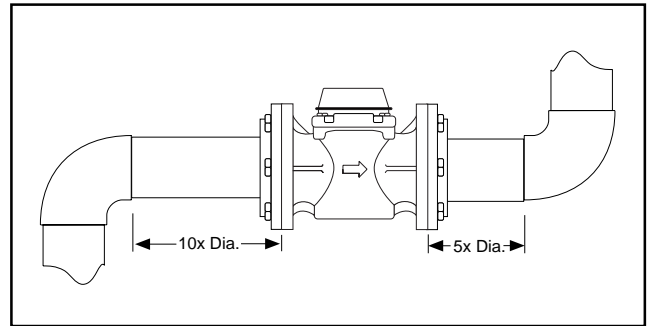

Flanges. Pipe flanges can be any standard 150 lb. drilling, flat or raised face. Partial or full-face gaskets may be used, but take care to insure that the gasket does not protrude into the meter due to misalignment. Adhering the gasket to the meter flange with gasket adhesive is a good practice which will aid installation.

Position. WP Series are all-position meters, and can be installed horizontally or vertically.

Connections. For the contacting head option, WP meters use a meter-mounted reed switch to provide a two-wire dry contact. See the Connections diagram on page 2.

Maintenance and Repair

Recalibration. For meters used for revenue-billing purposes, some states require periodic calibration checking. This type of turbine meter is most commonly checked every four years. Testing may be done by a local mobile meter service or in a private or municipal meter shop. Changes in calibration should be made at an authorized meter shop.

Register Removal. If the register must be replaced for any reason, follow these steps:

- 1) Remove the register cover by taking out the two screws which hold it in place.
- 2) Remove the locking ring at the base of the register by first removing its key segment, then rotating the ring until it comes loose.
- 3) Lift the register free from the meter.

Reed Sensor Installation

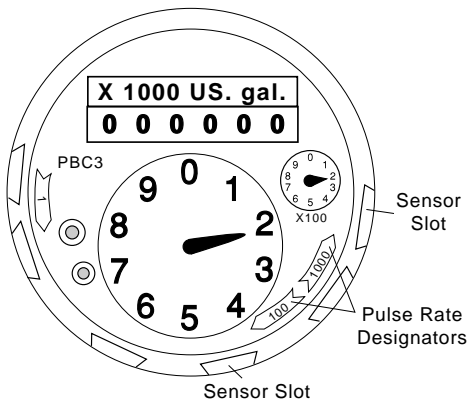

Turbine Insert Removal. The entire insert comes out as a unit. After relieving all pressure inside the meter, remove the four hex-head machine screws which hold the insert flange in place. Lift the flange off, rocking it if necessary to break the seal. Remove the screws which hold the insert to the flange. If necessary, the flange may now be reinstalled to allow restoration of pressure in the pipe while the insert is being repaired or replaced.

Reed Sensor Removal/Installation. To install or remove a reed sensor, first loosen the sensor cable strain relief. Then remove the two screws which hold the register cap in place and unsnap and lift off the cap. Finally, lift upwards on the reed sensor to slide it out of its dovetail slot.

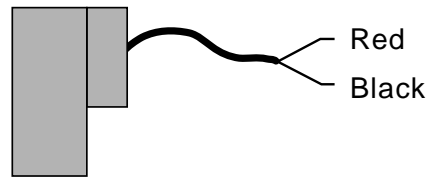

Type: Reed switch

Current Rating: 100 mA, 24 VAC maximum

To determine where to install a reed sensor, find the pulse rate designator which corresponds to the desired pulse rate. Start the sensor into the slot nearest the arrow point of that designator. Start the sensor into the slot, and push firmly until it bottoms. See photo at the lower left.

WPR Meter Pulse Chart					
Meter Size	2"	3"	4"	6"	8"
Gallons per Pulse	100	100	100	100	100
	•	•	1000	1000	1000