

General Information

The FT420 is a loop-powered microcontroller-based transmitter/indicator. It displays rate and total, and provides a 4-20 mA analog signal proportional to flow. A programmable pulse output is also standard for metering pump control or data logging.

The rugged cast-aluminum housing is gasketed for maximum environmental protection, and the electronics are potted into a solid block of urethane. A membrane keypad allows settings to be changed without removing the cover. The universal mount version comes with brackets for wall mounting, and also with an adaptor for field installation on 80-series flow sensors. The FT420 can also be factory or field installed on a TX100/200 series sensor or WT meter.

Specifications

Power	4 mA DC (4-20 mA loop), 12-32 VDC
Display	
Rate	6-digit autorange, 1/2" character height
Total	8-digit, 5/16" character height
Pulse Output	<ul style="list-style-type: none"> • 0.1 second open collector pulse (scaled) • sensor pulse (unscaled)
Input	Pulse frequency + 5 VDC
K factor Range	0.050 - 2000
Pulse Output Range	0.1 - 200,000 units/pulse
Temperature	0 C - 70 C
Environmental	NEMA 4X

Features

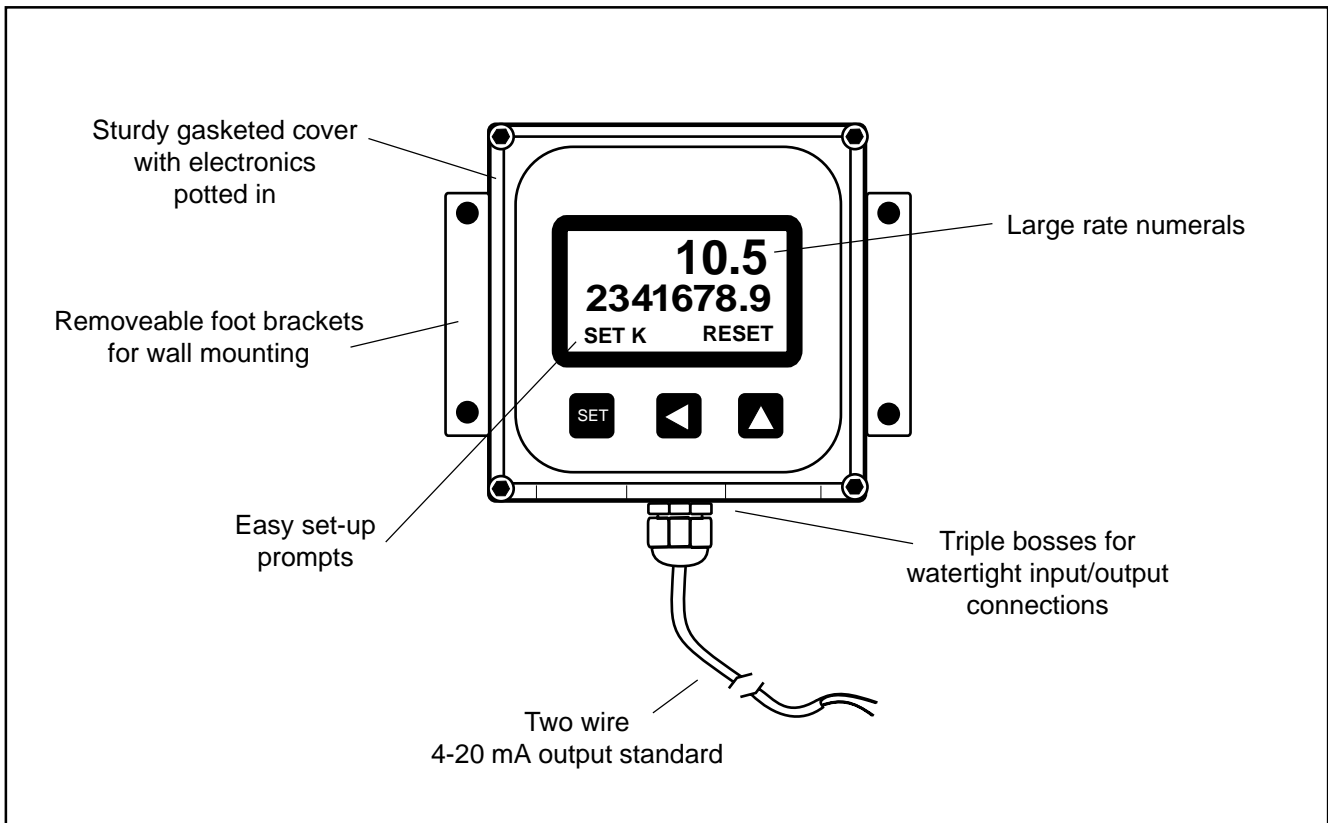

Installation

To mount the FT420 on a wall, hold the unit in the desired position, mark the holes in the mounting feet, drill, and mount with screws.

This unit can also be mounted directly on a flow sensor for local reading. If the unit was ordered as an FT420, factory mounted to the top of a 100 or 200 Series flow sensor, no further installation is required.

To mount the unit on a flow sensor, remove the housing cover. Place the lower half of the housing in the groove on the top of the flow sensor. An adaptor is included in the packaging of the FT420 which threads into the top of any 80-Series flow sensor. Pull the sensor wires through the hole in the center of this adaptor, then thread the adaptor into place. Tighten the adaptor using a screwdriver. (See diagram). Connect the wires, then replace the housing cover, orienting it any direction as desired for viewing convenience.

Connection

To connect to the FT420 to a flow sensor, follow the diagram marked "Connections". This diagram also shows the connections for an external device, such as a chemical metering pump.

If the 4-20 mA current signal is not required, connect the power terminals to any 12-30 VDC current source.

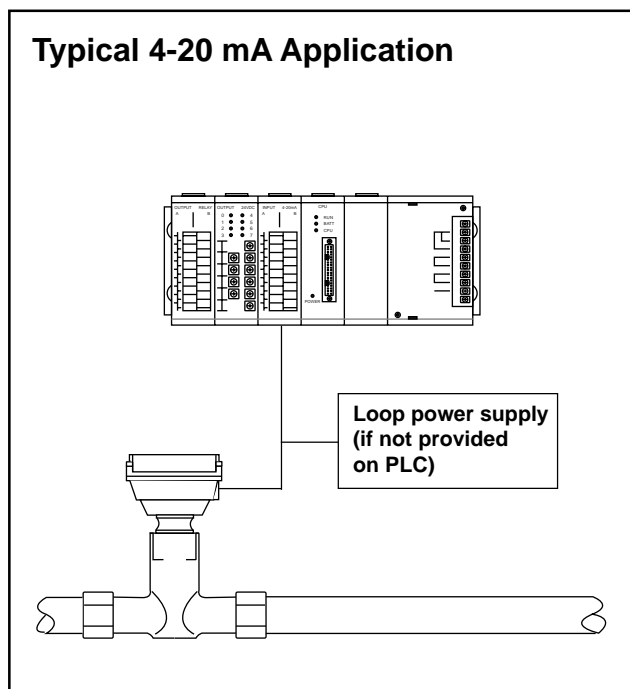

Programming



Caution: If output is being used to control an external device, such as a metering pump, do not connect the device until programming is completed. If malfunction or incorrect programming of the output could cause personal injury or property damage, separate safeguards must be installed to prevent such injury or damage.

At a minimum, every FT420 must be programmed with the "K-factor". This is simply the number of pulses per gallon which the meter or flow sensor produces. (If you wish the FT420 to read in another unit, enter the number of pulses per that unit. For example, if the desired units are liters, the K-factor is the number of pulses per liter that the flow sensor produces.)

To find the K-factor on any SeaMetrics flow sensor fitting or in-line meter, look on the model-serial label. The line reading $K = \text{xxxx}$ is the desired number. For adjustable sensors (101,201,115,215) look in the instruction manual under your pipe size.

Set K. Begin by pressing the key SET once. The prompt SET K should appear on the display. The digit to the far right will be blinking. Use the up arrow key to reach your desired digit. Then press the left arrow key to move to the next digit. Repeat the process until the entire number is entered. (Note that the decimal is fixed at three places. If you only have two decimal places for your K-factor, enter a zero for the third digit.)

Set P. If the pulse output is to be used, set the desired pulse rate. This is the number of gallons (or other units, if you are using them) between pulses. The second time the SET key is pressed, SET P will appear. Follow the same process as above to enter the desired number.

Set 20 mA. Set the flow rate, in units per minute, at which 20 mA is desired. The processor will automatically scale the 4-20 mA loop accordingly, with 4 mA at zero flow.

Set Decimal Point. The fourth time the SET key is pressed, a D prompt appears. Pressing the up arrow key switches back and forth between no decimal place and one decimal place.

Sensor Mount: Step 1

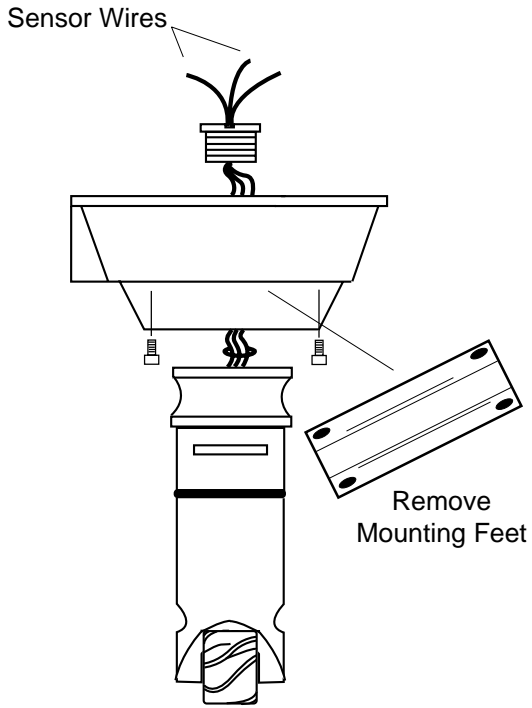

Sensor Mount: Step 2

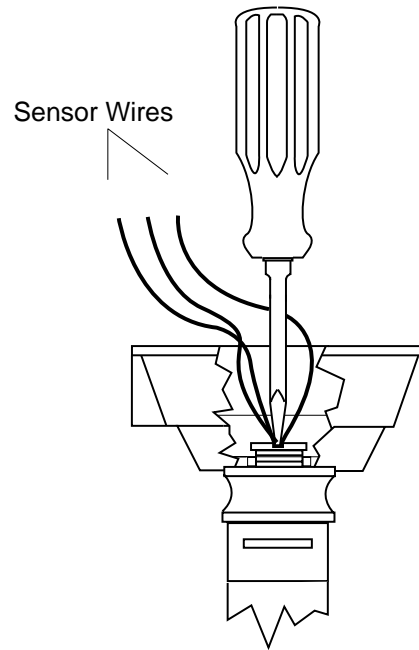

Standard Connections

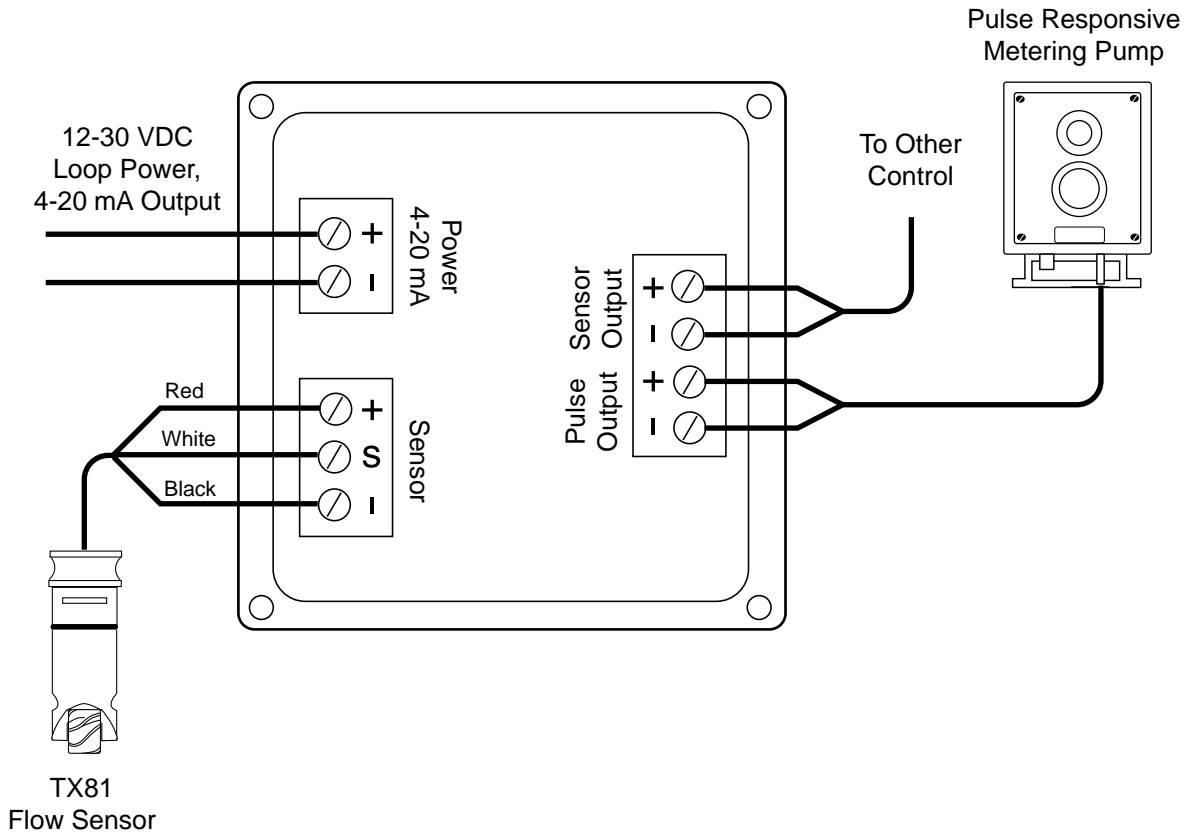

Operation

To return to normal operation after entering settings, press SET for a fifth time. The rate and total indicator numbers should appear in the display. If the unit is connected to an operating flow sensor, the larger-sized digits indicate flow rate and the smaller-sized digits indicate total.

Unless the unit has been ordered with the non-reset option, a RESET prompt is constantly visible in the lower right corner, above the up arrow key. Press this key at any time to reset the totalizer to zero.

Typical Chemical Metering Pump Applications

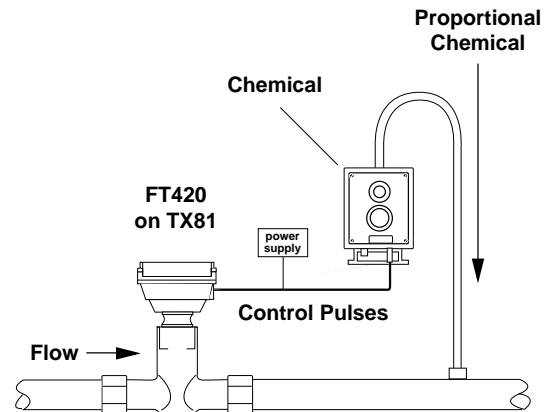

Dimensions

