



GREAT PLAINS INDUSTRIES, INC.

Positive Displacement Flowmeters

— GM4 series instruction manual —



GM4 Pulse • GM4 Standard LCD • GM4 Deluxe LCD • From serial No. CXXXX

MS345G
0899
0001

To the owner

Thank you for purchasing a GPI GM Series Flow Meter. Please take a few minutes to read through this manual before installing and operating your meter. If you have any problems with the meter, refer to the maintenance and trouble shooting sections of this manual.

This manual contains connection and operating instructions for the GM4 Series meters with pulse outputs and liquid crystal displays. For models with deluxe liquid crystal display an additional instruction manual is

supplied. If you need further assistance, contact your local GPI representative or contact GPI by telephone or fax for advice.

The GPI GM Series Flow Meter has incorporated the oval rotor principal into its design. This has proven to be a reliable and highly accurate method of measuring flow. Exceptional repeatability and high accuracy over a wide range of fluid viscosities and flow rates are features of the GM Series flow meter design. The low pressure drop and high pressure rating

means the GM Series flow meter is suitable for both gravity and pump (in line) applications.

The GPI GM Series flow meters are available in either aluminum or 316 stainless steel. Standard rotors are made from PPS (Polyphenylene Sulfide Resins) with optional 316 stainless steel rotors available for both stainless steel and aluminum models.

The GM4 Series is available with either;

- * Standard Pulse
- * Standard LC Display and Pulse
- * Deluxe LC Display and Pulse

Important Information



PLEASE READ THIS INFORMATION CAREFULLY BEFORE USE!

Before use, confirm the fluid to be used is compatible with the meter (refer to the GPI fluid compatibility chart), or consult your local GPI representative for advice.

This meter will handle particle sizes up to 0.25mm/0.011".

To prevent damage from dirt or foreign matter, GPI recommends a Y or Basket type 60 mesh strainer be installed as close as possible to the inlet side of the meter (if required contact GPI for further information).

Note: When a strainer is installed it should be regularly inspected and cleaned. Failure to keep the strainer clean will dramatically effect flow meter performance.

To prevent damage to the meter slowly fill the system with fluid (this will prevent damage caused by air purge).

Note: Failure to do this could damage the meter.

For pump applications, turn off the pump at the end of each day.

Maintenance can be carried out to the liquid crystal displays and pulse units without removing or isolating the meter from the line. When maintenance to any other part of the

meter is required, the meter must be isolated and the line pressure reduced.

The reed switch pulse unit can cause inaccurate rate counts when used with high speed counters. It is advised that a debounce circuit be used or alternatively use the hall effect sensor option.

PTB - Deluxe LC Display
EEX1A IIC T6 (PTBnr EX-93.C4033X)

Installation

1] GPI recommends that when setting up pipework for meter installations a bypass line be included in the design. This provides the facility for a meter to be removed for maintenance without interrupting production. (See Fig.1)

2] Use thread sealant on all pipe threads.

3] For pump applications ensure pipe work has the appropriate working pressure rating to match the pressure output of the pump. The maximum working pressures are; 5500 kPa/ 800PSI/ 55 BAR

4] Install a wire mesh strainer (Y or basket type 60 mesh as close as possible to the inlet side of the meter.

5] Ensure that the meter is installed so that the flow of the liquid is in the direction of the arrows embossed on the meter body.

6] The meter can be installed in any

orientation as long as the meter shafts are in a horizontal plane. (Refer to Fig.2 for correct installation) The register assembly may be orientated to suit the individual installation.

Note: Incorrect installation can cause premature wear of meter components.

7] Do not over tighten meter connections.

8] **It is important that after initial installation you fill the line slowly, high speed air purge could cause damage to the rotors.**

9] Test the system for leaks.

10] Check the strainer for swarf or foreign material, after the first 200 litres check periodically, particularly if the flow rate decreases.

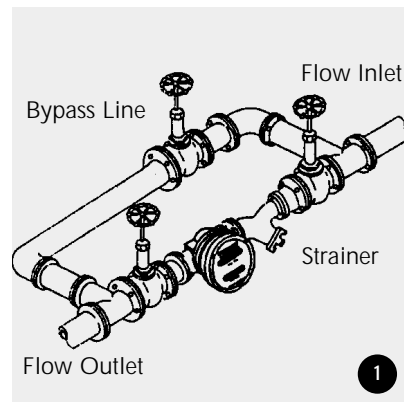

Operation

When fluid passes through the meter, rotors turn. The magnets which are located in the rotors will pass across the pulser circuit board (containing either Reed switches or Hall Effect

sensors). A signal is received which is then sent by the Pulse Circuit Board (PCB) to the relevant LC display or receiving instrument.

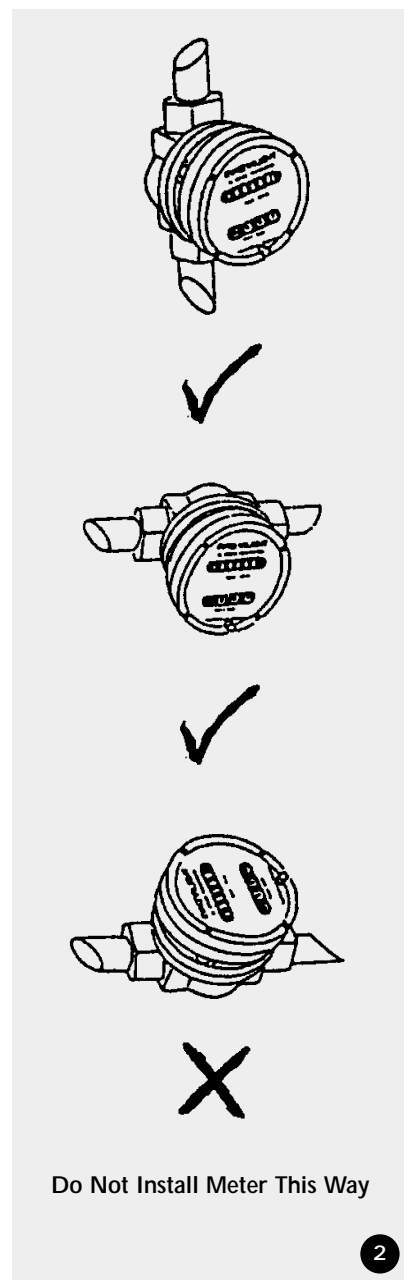
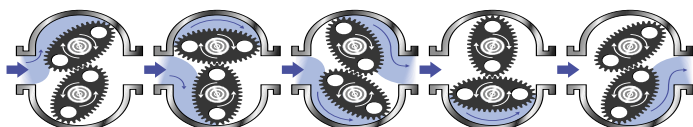

Electrical Connections

Reed Switch Connections for PCB Terminals - refer Fig.3

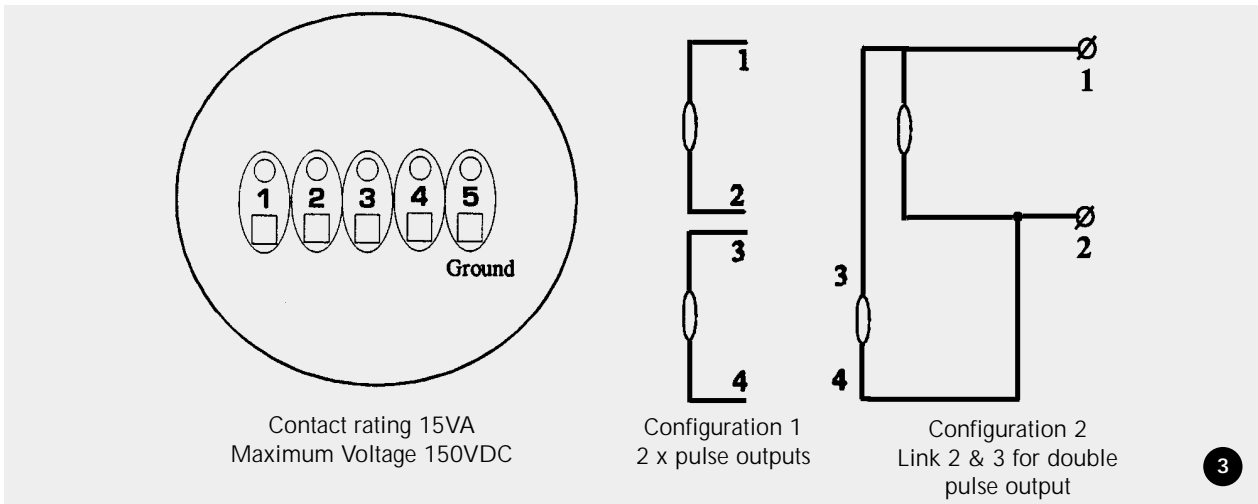

Hall Effect Sensor Connections - refer Fig.4

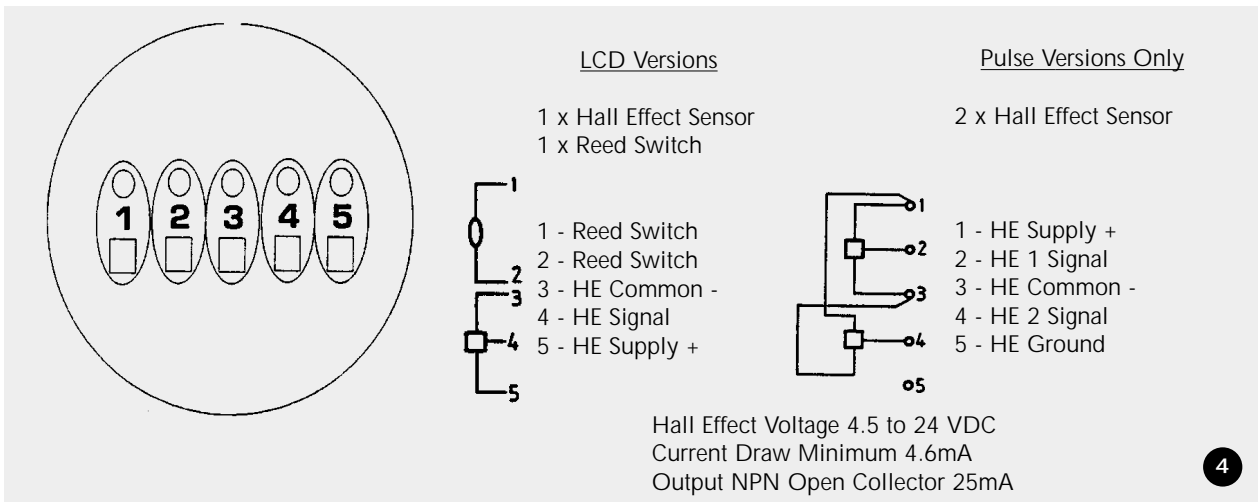

Service Instructions

Disassembly

Ensure that the fluid supply to the meter is disconnected, and the line pressure is released before disassembly, with the exception for repair or maintenance to the LC Display or PCB where there is no necessity to isolate the meter from

flow. Refer to the exploded parts diagram on pages 7 and 8 for item numbers.

1a] Units with Pulse Caps; Undo the conduit connector, remove pulse cap (9) and remove the wires from the pulse terminal board (item 5).

1b] Standard LC Display; Mark the display orientation with a marking pen, unscrew the four large screws (Item 30) on top of the LC Display. Carefully separate the LC Display from the plastic housing and disconnect the wires from the pulse terminal block. (See Standard LC Display instructions).

1c] Deluxe LC Display; Mark the display orientation with a marking pen, remove the four retaining screws on the display face (Item 16). Lift off the display unit and remove the 9 pin connector at the back of the display unit. (Refer to separate Deluxe LC Display instruction manual).

2] Remove the mounting adaptor plate and gasket (Item 14).

3] Loosen the six cap head screws (Item 7) that hold down the meter cap (Item 4), remove the screws, washers and lift off the cap.

4] Remove the o'ring (Item 2) from the o'ring groove in the meter cap (Item 4).

5] Remove rotors (Item 3).

Reassembly

1] Before reassembling check the condition of the rotors (replace if necessary).

2] Check that the smooth side of the rotors (not the plug side) is facing you when inserting the rotors, the smooth side of the rotor is the magnet side. There is no difference between rotor one or rotor two.

3] Replace the rotors (Item 3) onto the shafts at 90° to each other (refer Fig. 5) and check their operation by turning either of the rotors. If the rotors are not in mesh correctly or do not move freely, remove one of the rotors and replace correctly at 90° to the other rotor. Re-check the operation of the rotors.

4] Replace the o'ring (Item 2) into groove in the meter cap, if the o'ring has grown or is damaged in any way replace it with a new part.

5] Replace the meter cap making sure that the locating pin in the body lines up with the hole in the meter cap. Insert the cap head screws (Item 7) and tighten in the sequence 1, 4, 2, 5, 3, 6.

6] The replacement of cables and connectors are a reversal of the disassembly procedure, replace conduit fitting if required. When replacing the Standard LC Display or the Deluxe LC Display, confirm the orientation marks made on disassembly are aligned then screw the register into place.

7] Test the meter by turning the rotors with a finger or by applying very low air pressure (no more than a good breath) to one end of the meter,

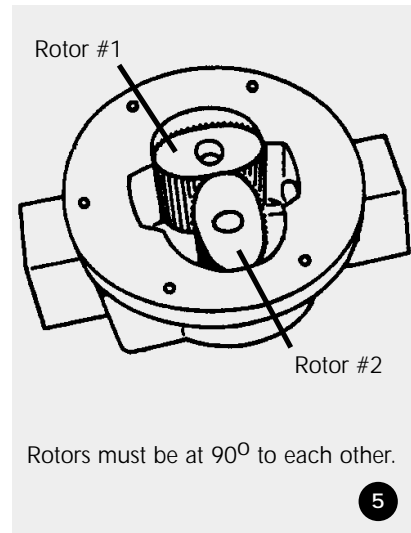

before returning the meter to the line.

Pulse Circuit Board (PCB) Notes:

The PCB (Item 5) is fitted with (A) two reed switches; (B) hall effect sensors; or (C) one reed switch and one hall effect sensor. The PCB board is fastened to the meter cap (Item 4) by two screws and stand off's. All care and caution should be taken when removing or handling the PCB as both the reed switch and hall effect sensor are fragile.

Individual reed switches or hall effect sensors are not available as individual replacement parts and are only available with the PCB (Item 5).

Standard LC Display

This section of the instruction manual assists you in the operating of the GPI Standard LC Display. Please take a few minutes to acquaint yourself with the information that follows.

Replace Battery

1] Remove the two large screws (Item 30) and the two small screws (Item 31) from the battery cover plate (Item 29).

2] Remove the battery cover plate



Standard LC Display

(Item 29) and gasket (Item 28).

3] Remove battery, and clean any corrosion from the battery terminals (to protect terminals from corrosion or condensation coat the terminals with petroleum jelly).

4] Install the new battery.

5] Check gasket (Item 28) for damage (replace if required). Position gasket (Item 28) and cover plate (Item 29) correctly, insert the screws and tighten.

Display Operation

All meter operations are reflected in the readout on the face of the meter. The readout contains three lines of information; refer to Fig. 7.

Note: The calibration is preset and is permanently stored in the meter's computer.

The meter will turn on automatically when the liquid flows through the meter. The meter can also be turned on manually by pressing and releasing the display button.

Turn Off

The meter turns off automatically two minutes after flow stops. When the meter is off, the readout is blank.

Batch Total

The resettable batch total indicates flow during a single use. This total can be reset by holding down the display button for three seconds until zeros appear. The batch total can be found by pressing and releasing the display button

until the bottom line displays "Total 2".

Cumulative Total

The cumulative total is the total of all the liquid measured since the meter's power supply was connected. This total cannot be manually zeroed, but will zero when the battery has been removed, goes dead, or when it reaches the maximum value of 999,999.

The cumulative total can be found by pressing and releasing the display button until the bottom line displays "Total 1 Locked".

Flow Rate

The flow rate is the rate the fluid is flowing through the meter. The flow rate setting can be found by pressing and releasing the display button until the bottom line displays "flow rate".

Propeller

Any time liquid flows through the meter, a small propeller displays.

Battery Replacement

Your meter is powered by a 9 volt lithium battery. (Replacement batteries; Lithium U9VL, Alkaline 522 or MN1604). If the meter's readout should become dim or blank, the battery should be replaced.

When the battery either falls or is disconnected the batch and cumulative totals return to zero. The factory calibration is retained in the meter's computer permanently and will not be affected by battery failure.

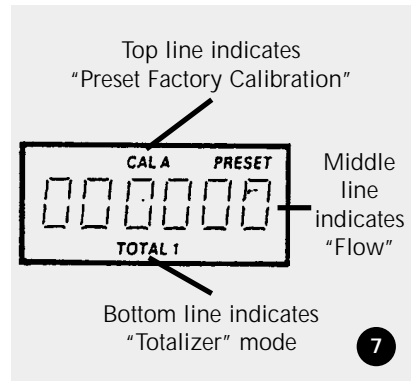

Auxiliary Facilities

Connection of an external 12 volt DC power supply facility;

1] Remove the 4 large screws (Item 30) and remove the register from the coverplate.

2] Disconnect the internal battery.

3] Solder the external power leads to the terminals marked 'Ext 12V' on the registers printed circuit board.

4] Re-assemble the register onto the coverplate, replace the 4 screws (Item 30) and screw firmly together.

Connection of external pulse output

1] Remove the 4 large screws (Item 30) and remove the register coverplate.

2] Connect external signal lead. (Refer Fig. 8)

Pulse O/P and Ext Power are the connections located on the interface PCB, to use this output a 1K resistor will need to be soldered between the + voltage of the external power input and the + of the pulse O/P. Pulse signal represents the output cabling to the receiving instrument.

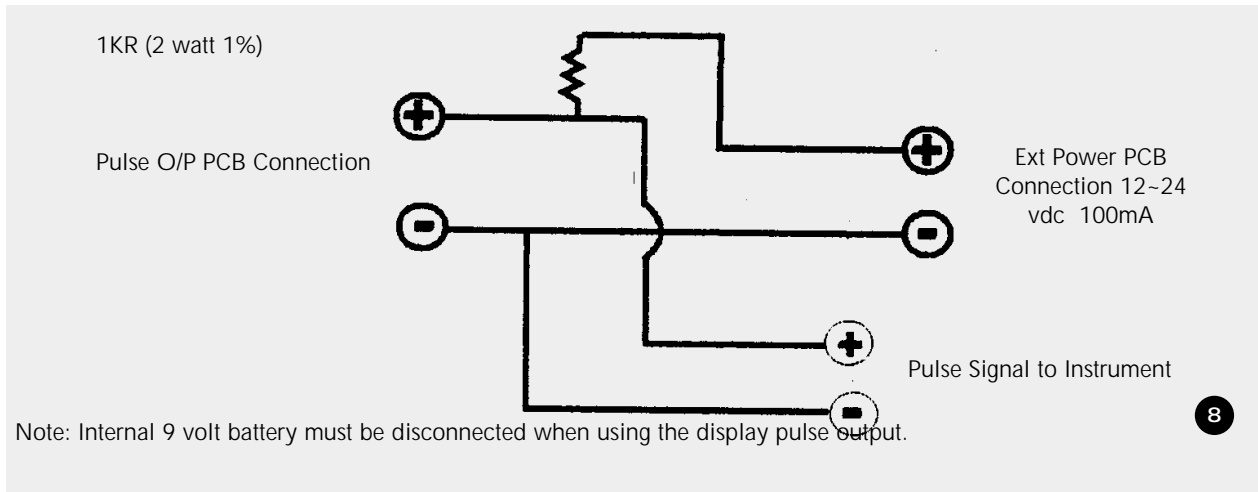

Meter Trouble Shooting

TROUBLE SHOOTING GUIDE		
TROUBLE	CAUSE	REMEDY
Fluid will not flow through meter	<ul style="list-style-type: none"> a] Foreign matter blocking rotors b] Line strainer blocked c] Damaged rotors d] Meter connections over tightened e] Fluid is too viscous 	<ul style="list-style-type: none"> a] Dismantle meter, clean rotors (Strainer must be fitted in line) b] Clean strainer c] Replace rotors (Strainer must be fitted in line) d] Re-adjust connections e] See specifications for maximum viscosity
Reduced flow through the meter	<ul style="list-style-type: none"> a] Strainer is partially blocked b] Fluid is too viscous 	<ul style="list-style-type: none"> a] Clean strainer b] See specifications for maximum viscosity
Meter reading inaccurate	<ul style="list-style-type: none"> a] Fluid flow rate is too high or too low b] Fluid is too viscous c] Excess wear caused by incorrect installation 	<ul style="list-style-type: none"> a] See "specifications" for minimum and maximum flow rates b] Consult GPI c] Check meter body and rotors. Replace as required. Refer to installation instructions
Meter not giving a pulse signal	<ul style="list-style-type: none"> a] Faulty hall effect sensor b] Faulty reed switch c] Magnets failed 	<ul style="list-style-type: none"> a] Replace PCB Board b] Replace PCB Board c] Replace magnets
LCD Register not working	<ul style="list-style-type: none"> a] Battery not connected properly b] Battery flat c] Faulty wiring connections d] Faulty LC display e] Faulty connection from LC display to Pulse PCB 	<ul style="list-style-type: none"> a] Check battery connections b] Replace battery c] Check wiring for loose or faulty connections d] Replace LC display e] Check wiring connections

Meter Parts Listing

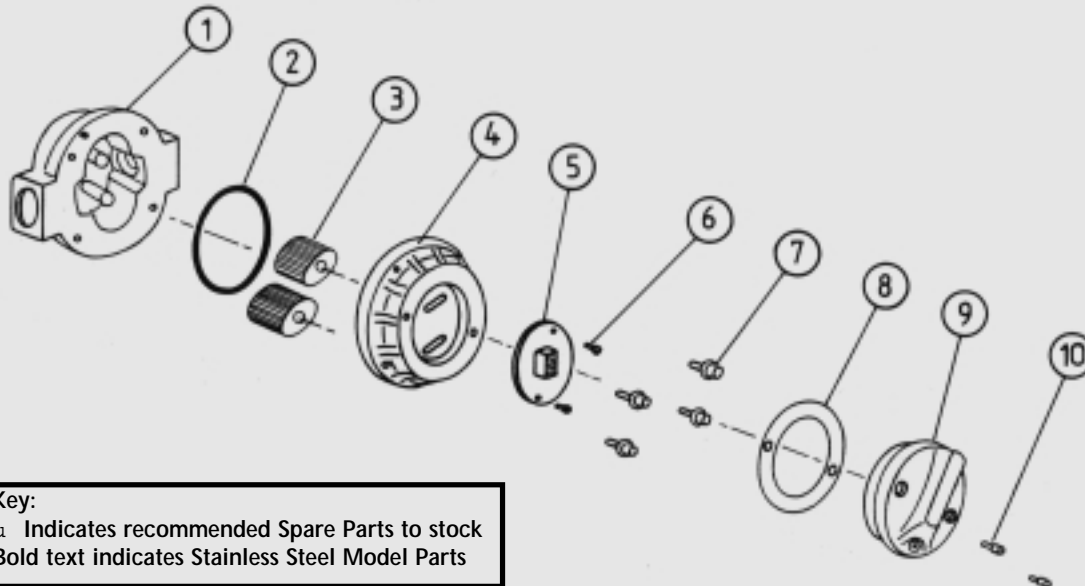

Key:
 u Indicates recommended Spare Parts to stock
 Bold text indicates Stainless Steel Model Parts

Item No.	No. Off.	Rec. Parts	Part or Set (Order from this column only)	Part Description
1	1		MS298B	Meter Body 1/2" BSP (Aluminium)
1	1		MS298N	Meter Body 1/2" NPT (Aluminium)
1	1		MS337B	Meter Body 1/2" BSP (Stainless Steel)
1	1		MS337N	Meter Body 1/2" NPT (Stainless Steel)
2	1	*	BS145	"O" Ring (NBR)
2	1	*	BS145E	"O" Ring (EPDM)
2	1	*	BS145TE	"O" Ring (Teflon)
2	1	*	BS145V	"O" Ring (Viton)
3	2	*	MS342S	Rotors PPS (Polyphenylene Sulfide Resins)
3	2	u	MS342-1S	Rotors (Stainless Steel)
3	2	*	MS342TS	High Temperature Rotors (PPS)
3	2	*	MS342HS	High Viscosity Rotors (PPS)
3	2	*	MS342HTS	High Viscosity/High Temperature Rotors (PPS)
3	2	*	MS342-1HS	High Viscosity Rotors (Stainless Steel)
4	1		MS297	Meter Cap (Aluminium)
4	1		MS338	Meter Cap (Stainless Steel)
5	1	*	MS344-R	PCB (Standard Reed Switch)
5	1	*	MS344-HE	PCB (Hall Effect Sensor)
5	1		MS344-R/HE	PCB (1 Reed Switch & 1 Hall Effect Sensor)
6	2		MS284S	PCB Board Screws
7	4	*	MS346S	Meter Cap Screws (Standard)
7	4	*	MS350S	Meter Cap Screws (Stainless Steel)
8	1	*	MS340	Pulsor Cap Gasket
9	1		MS296	Pulsor Cap (Aluminium) 16mm Conduit Thread
9	1		MS296N	Pulsor Cap (Aluminum) 1/2" NPT Thread
9	1		MS339	Pulsor Cap (Stainless Steel) 16mm Conduit Thread
9	1		MS339N	Pulsor Cap (Stainless Steel) 1/2" NPT Thread
10	2		MS347S	Pulsor Cap Screw (Stainless Steel)
11	1		MS37	Warning Label (Not Shown)
12	1		MS14	Explosion Proof Approval Label (Not Shown)
13	1		Customer to Specify	Legend Plate (Not Shown) inc. Hammer Screws

Display Parts Listing

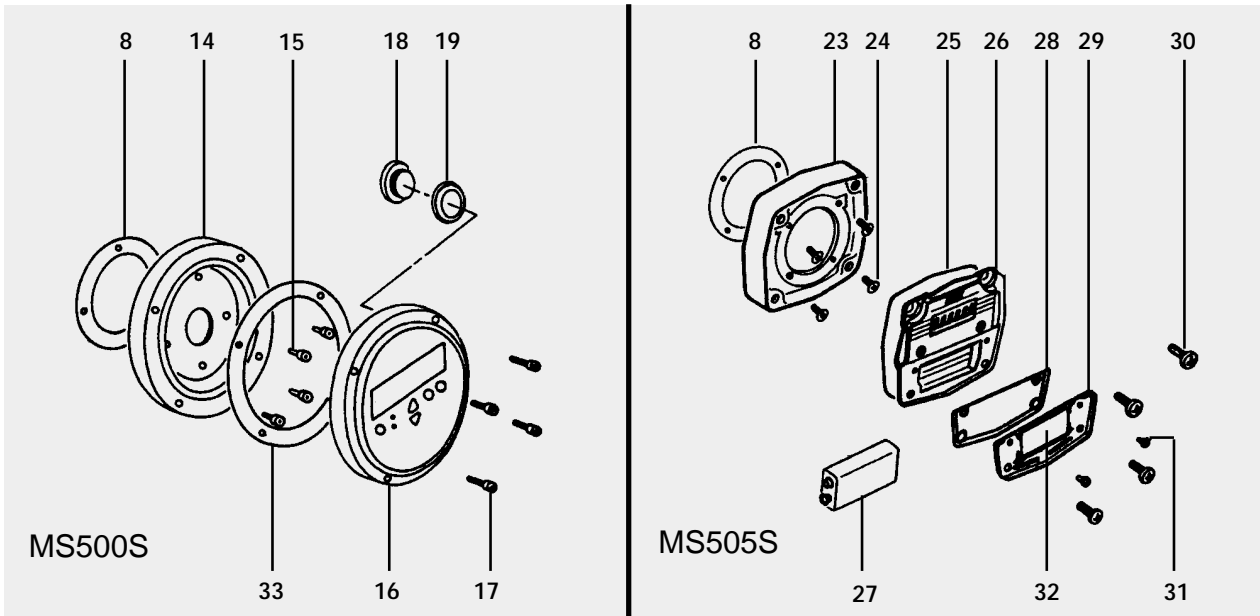

Item No.	No. Off.	Rec. Parts	Part or Set (Order from this column only)	Part Description
			MS500S	Deluxe LCD Display (Complete)
14	1		MS349	Mounting Adaptor Plate
15	4	*	MS117S	Adaptor Screws
16	1	*	MS69	LC Display Unit
17	4	*	MS118S	LC Display Mounting Screws
18	1	*	MS127	Battery Retaining Screw
19	1	*	MS126	Battery (Standard) CR2040
20	1	*	MS68	Connector and Cable (Not Shown)
21	1	*	MS87	PTB Approval Label (Not Shown)
22	1	*	MS128	Extended Life Battery 2/3 AA (Not Shown)
33	1	*	MS307	NOTE: Note Suitable for Intrinsic Use Gasket
			MS505S	Standard LC Display (Complete)
23	1		MS348	Mounting Adaptor Plate
24	4	*	MS203S	Adaptor Screws
25	1	*	BS045	"O" Ring
26	1	*	MS205	LC Display
27	1	*	MS274	9 Volt Battery
28	1	*	MS184S (Inc. MS184B)	Battery Gasket
29	1	*	MS184S (Inc. MS184A)	Battery Cover
30	4	*	MS206S	Register Screws
31	4	*	MS182S	Battery Cover Plate Screws
32	1		Customer to Specify	Battery Cover Label

Meter Specifications

Meter Type	Pulse	Pulse with Standard LC Display	Pulse with Deluxe LC Display
Flow Ranges (Litres per minute/US Gallons per minute)			
Above 5 Centipoise	1 to 30/ 0.26 to 8	1 to 30/ 0.26 to 8	1 to 30/ 0.26 to 8
Below 5 Centipoise	3 to 25/ 0.8 to 6.60	3 to 25/ 0.8 to 6.60	3 to 25/ 0.8 to 6.60
Accuracy of Reading	+/- 0.5%	+/- 0.5%	+/- 0.5%
Maximum Viscosity*	1000 Centipoise	1000 Centipoise	1000 Centipoise
Maximum Operating Pressure	5500 kPa/ 800 PSI/ 55 BAR	5500 kPa/ 800 PSI/ 55 BAR	5500 kPa/ 800 PSI/ 55 BAR
Maximum Operating Temperature	80°C/ 176°F (Stainless Steel Models 120°C/ 248°F)	80°C/ 176°F (Stainless Steel Models 120°C/ 248°F)	80°C/ 176°F (Stainless Steel Models 120°C/ 248°F)
Pulse Type	Dual Reed Switches or Hall Effect Sensor or combination HE Sensor/Reed Switch	Dual Reed Switches or Hall Effect Sensor or combination HE Sensor/Reed Switch	Dual Reed Switches or Hall Effect Sensor or combination HE Sensor/Reed Switch
Pulses Per Litre/US Gallon	112 / 224 or 424/ 828	112 / 424	112 / 424

* Unless High Viscosity or High Temperature Rotors are fitted

Meter Dimensions

GM4 Pulse Meter Dimensions

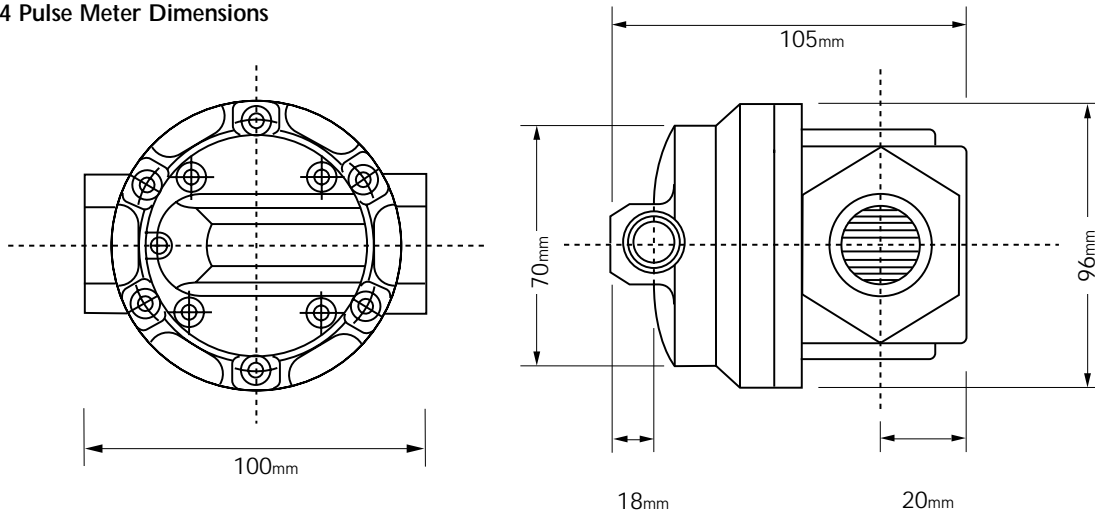

GM4 Pulse Meter with Standard LC Display

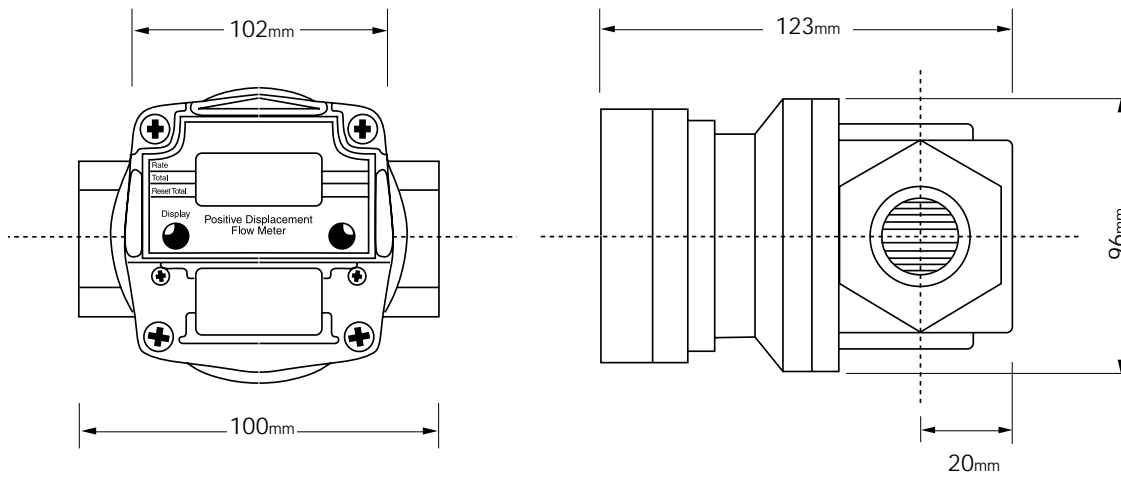

GM4 Pulse Meter with Deluxe LC Display

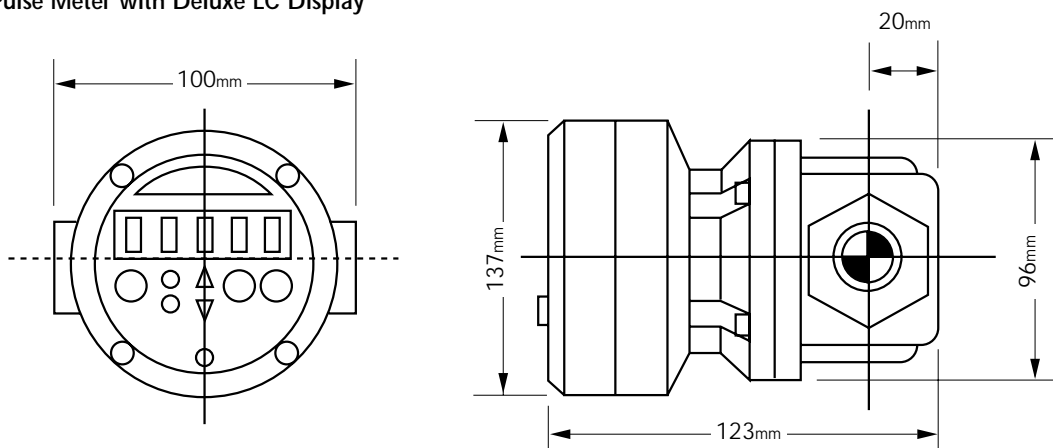

Warranty

Great Plains Industries, Inc. Limited Warranty Policy

Great Plains Industries, Inc., 5252 East 36th Street North, Wichita, Kansas USA 67220-3205, hereby provides a limited one year warranty against defects in material and workmanship on all products manufactured by Great Plains Industries, Inc. This warranty shall extend to the purchaser of this product and to any person to whom such product is transferred during the warranty period.

The warranty period shall begin on the date of the original new equipment purchase. Warrantor's obligation hereunder shall be limited to repairing defective workmanship or replacing or repairing any defective part or parts. This warranty shall not apply if:

- a.)The product has been altered or modified outside the warrantor's duly appointed representative;
- b.)The product has been subjected to neglect, misuse, abuse or damage or has been installed or operated other than in accordance with the manufacturer's operating instructions.

To make a claim against this warranty, notice of claim must be given in writing to the company at its address below no later than 30 days after the expiration of the warranty period. Such notice shall identify the defect in the product. The company shall, within 14 days of receipt of such notice, notify the customer to either send the product, transportation prepaid, to the company at its office in Wichita, Kansas, or to a duly authorized service center. The company shall perform all obligations imposed on it by the terms of this warranty within 60 days of receipt of the defective product.

GREAT PLAINS INDUSTRIES, INC. EXCLUDES LIABILITY UNDER THIS WARRANTY FOR DIRECT, INDIRECT, INCIDENTAL AND CONSEQUENTIAL DAMAGES INCURRED IN THE USE OR LOSS OF USE IF THE PRODUCT WARRANTED HEREUNDER.

The company herewith expressly disclaims any warranty of merchantability or fitness for any particular purpose other than for which it was designed.

This warranty gives you specific rights and you may also have other rights which vary from U.S. state to U.S. state.

NOTE: In compliance with MAGNUSON MOSS CONSUMER WARRANTY ACT - Part 702 (governs the resale availability of the warranty terms).



5252 East 36th Street North
Wichita, KS USA 67220-3205
TEL: 316-686-7361
FAX: 316-686-6746
