



**DYNASONICS**

# **Series TFXL**

**Transit Time Ultrasonic Flow Meter  
Remote Mount System**

Operations & Maintenance  
Manual

REV 12/03

# TABLE OF CONTENTS

		<b>Pages</b>
	Quick-Start Operating Instructions	1.3-1.4
<b>Part 1 - Introduction</b>	Introduction	
	General	1.5
	Applications	1.5
	Model Matrix	1.6
	Product Specifications	1.7
	Components and Terminology	1.8
<b>Part 1 - Connections</b>	Transmitter Connections	
	Transmitter Limits and Installation	1.9
	Power and Transducer Connections	1.10-1.12
<b>Part 1 - Inputs and Outputs</b>	Input/Output Connections and Options	
	4-20 mA Output	1.13-1.14
	Turbine Meter Simulation	1.15
	TTL Pulse Output	1.15-1.16
	Application of Power and Troubleshooting	1.17-1.18
<b>Part 2 - Transducer Installation</b>	Transducer Mounting	
	Mounting Location	2.1-2.2
	Transducer Mounting Method	2.3-2.5
	Transducer Spacing	2.7-2.13
	Pipe Preparation	2.14
	Transducer Mounting	2.15-2.20

# TABLE OF CONTENTS

	<b>Pages</b>	
<b>Part 3 - Programming</b>	Software Utility Operation	
	Programming Entries	
	General Programming Information	3.1-3.2
	BASIC MENU	3.3
	FLOW MENU	3.4-3.6
	ADVANCED MENU	3.7-3.8
	OUTPUT MENU	3.9-3.10
	DISPLAY MENU	3.11
	Flow Meter Calibration	3.12-3.14
<b>Appendix</b>	Appendix	
	Fluid Characteristic Table	
	TFX Error Codes	
	Pipe Dimension Chart: Cast Iron	
	Pipe Dimension Chart: ST, SS, PVC	
	Velocity to Volumetric Conversion	
	Statement of Warranty	
	Customer Service	

# QUICK-START OPERATING INSTRUCTIONS

## Transducer Location

This manual contains detailed operating instructions for all aspects of the TFXL instrument. The following condensed instructions are provided to assist the operator in getting the instrument started up and running as quickly as possible. This pertains to basic operation only. If specific instrument features are to be used or if the installer is unfamiliar with this type of instrument, refer to the appropriate section in the manual for complete details.

### 1. TRANSDUCER LOCATION

- A. In general, select a mounting location on the piping system with a minimum of 10 pipe diameters (10 X the pipe inside diameter) of straight pipe upstream and 5 straight diameters downstream. The installation location should also be positioned so that the pipe remains full when the liquid is flowing through it. On horizontal pipes the transducers should be located on the sides of the pipe. **See Figure 1.2.** See **Table 2.1** for additional configurations.
- B. Select a mounting method, **Figure 1.1**, for the transducers from **Table 2.2**, based on pipe size and liquid characteristics. In general, select **W-Mount** for plastic and steel pipes flowing clean, non-aerated liquids in the 1-6 inch [25-150 mm] internal diameter range. Select **V-Mount** for pipes of all materials and most liquids in pipe sizes from 3-16 inches [75-400 mm]. Select **Z-Mount** for pipes larger than 16 inches [400 mm].
- C. Enter the parameters listed in **Table 1.1** via the TFXL UltraLink software utility.
- D. Record the value calculated and displayed as Transducer Spacing/XDCR SPC.

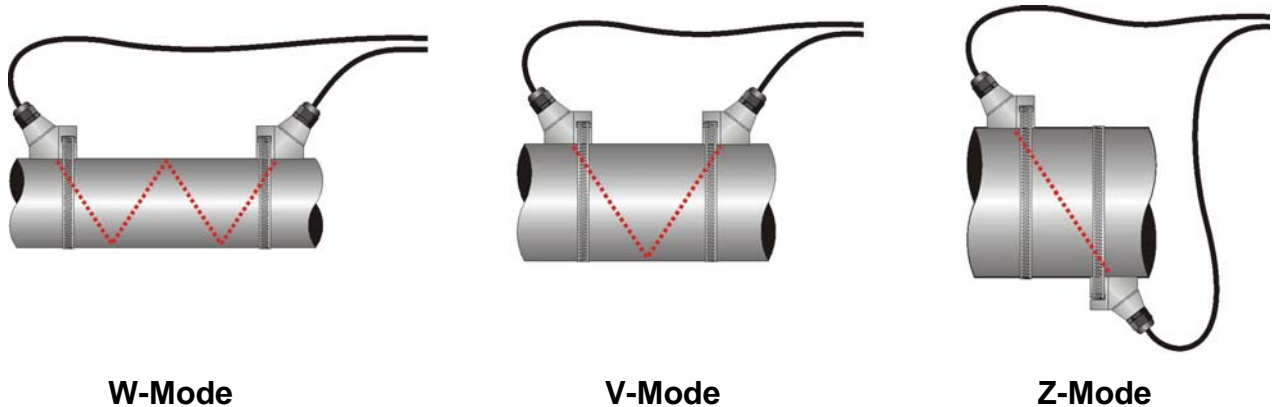

**Figure 1.2**  
**Transducer Mounting Configurations**

# QUICK-START OPERATING INSTRUCTIONS

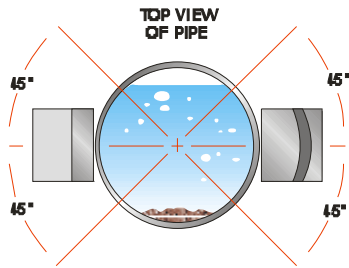

OPTIMAL TRANSDUCER MOUNTING LOCATIONS

**Figure 1.2  
Transducer  
Orientation**

## Connections

## Startup

**TABLE 1.1**

1. Transducer mounting method	7. Pipe liner thickness
2. Pipe O.D. (Outside Diameter)	8. Pipe liner material
3. Pipe wall thickness	9. Fluid type
4. Pipe material	10. Fluid sound speed*
5. Pipe sound speed*	11. Fluid viscosity*
6. Pipe relative roughness*	12. Fluid specific gravity*

\* Nominal values for these parameters are included within the TFXL operating system. The nominal values may be used as they appear or may be modified if exact system values are known.

## 2. PIPE PREPARATION AND TRANSDUCER MOUNTING

- A. The piping surface, where the transducers are to be mounted, needs to be clean and dry. Remove loose scale, rust and paint to ensure satisfactory acoustical bonds.
- B. Apply a 1/4" [6 mm] wide bead of couplant, lengthwise onto the transducer faces. Place each transducer onto the pipe ensuring proper linear and radial placement.
- C. Tighten the transducer mounting straps sufficiently to squeeze the couplant out along the flat surface of the transducer, filling the void between the transducer and the pipe wall.

## 3. TRANSDUCER/POWER CONNECTIONS

- A. If additional cable is to be added to the transducers, utilize 20 AWG twisted-pair cable and ensure that both cables are of equal length.
- B. Refer to the TFXL Field Wiring Diagram located within section one of this manual and the terminal block labels for proper power and transducer connections. Verify that the voltage level listed on the product identification label—located on the side of the instrument enclosure— matches the power source where connection is being made.

## 4. INITIAL SETTINGS AND POWER UP

- A. Apply power to the instrument.
- B. Verify that SIG STR is greater than 3%.
- C. Verify that measured liquid SSPD is within 0.5% of the configuration value.
- D. Input proper units of measure and I/O data.

## PART 1 - INTRODUCTION

### General

The TFXL ultrasonic flow meter is designed to measure the fluid velocity of liquid within closed conduit. The transducers are a non-contacting, clamp-on type, which will provide benefits of non-fouling operation and ease of installation.

TFXL transit time flowmeters utilize two transducers that function as both ultrasonic transmitters and receivers. The transducers are clamped on the outside of a closed pipe at a specific distance from each other. The transducers can be mounted in V-mode where the sound transverses the pipe two times, W-mode where the sound transverses the pipe four times, or in Z-mode where the transducers are mounted on opposite sides of the pipe and the sound crosses the pipe once. This selection is based on pipe and liquid characteristics. The flowmeter operates by alternately transmitting and receiving a frequency modulated burst of sound energy between the two transducers (contrapropagation) and measuring the time interval that it takes for sound to travel between the two transducers. The difference in the time interval measured is directly related to the velocity of the liquid in the pipe.

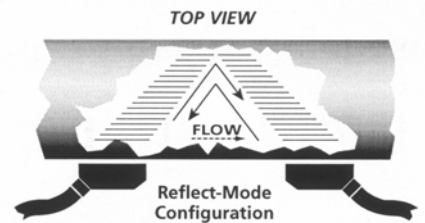

### Application Versatility

The TFXL flow meter can be successfully applied on a wide range of metering applications. The simple to program transmitter allows the standard product to be used on pipe sizes ranging from 2 - 100 inch [ 50 - 2540 mm ] pipe. A variety of liquid applications can be accommodated: ultrapure liquids, potable water, chemicals, raw sewage, reclaimed water, cooling water, river water, plant effluent, etc. Because the transducers are non-contacting and have no moving parts, the flow meter is not affected by system pressure, fouling or wear. Standard DTTN transducers are rated to 300°F [150°C]. Temperatures to 450°F [230°C] can be accommodated with Series DTTH transducers. Please consult the Dynasonics factory for assistance.

# PART 1 - INTRODUCTION

## User Safety

The TFXL employs modular construction and provides electrical safety for the operator. The display face and keypad contains voltages no greater than 10 Vdc. The wiring access panel provides users access to wiring terminals without risking damage to flow meter circuits. Disconnect electrical power before opening the instrument enclosure.

## Data Integrity

Non-volatile flash memory retains all user-entered configuration values in memory indefinitely, even if power is lost or turned off.

## Product Identification

The serial number and complete model number of your TFXL is located on the side of the instrument enclosure. Should technical assistance be required, please provide the Dynasonics Customer Service Department with this information.

## Product Matrix

D T F X L  ■ X   ■ N N

### Display Options

- 1) Blind
- 2) Rate and Totalizer Display

### Output Options

- 1) 4-20 mA and Turbine-type
- 2) 4-20 mA and TTL Pulse

### Connector Options

- N) ½-inch Conduit Hole
- A) Water-tight Cable Clamp
- C) Circular MIL-style Connector

D T T  ■    ■    ■

### Construction

- N) Standard
- H) High Temp

### Cable Length

- 020) 20 feet [6.1 m]
- 050) 50 feet [15 m]
- 100) 100 feet [30 m]
- Maximum length: 990 feet [306 m]
- in 10 foot [3 m] increments

### Conduit Type

- A) Flexible armored
- N) none

### Conduit Length

(Standard construction: Conduit length = Cable length)

- 000) none
- 020) 20 feet [6.1 m]
- 050) 50 feet [15 m]
- 100) 100 feet [30 m]
- Maximum length: 990 feet [306 m]
- in 10 foot [3 m] increments

### Options

- N) standard
- X) Intrinsically Safe

# PART 1 - SPECIFICATIONS

## DESCRIPTION

## SPECIFICATION

Liquid types	Most any liquid containing less than 40% total suspended solids (TSS) or aeration
Power requirements	11-30 VDC @ 0.25A
Velocity	.1 to 40 FPS [0.03 to 12.4 MPS]
Inputs/Outputs	4-20mA Output (standard output) Resolution of    12-bit for all outputs Power            Source Insertion loss    5V max Loop impedance   900 ohms max. Isolation         Can share ground common with power supply Turbine Frequency Output Type             Non-ground referenced AC Amplitude        100mVpp minimum Frequency range   0-1,000Hz maximum Duty cycle        50% ±10% TTL—Pulse Output Type             Ground referenced square-wave Amplitude        5VDC Frequency Range   0-1,000Hz maximum Duty Cycle        50% ±10%
Display	Type    2 line x 8 character LCD; top row: 0.7" [18mm] tall, 7-segment; Bottom row: 0.35" [9mm] tall, 14-segment none Rate    8 maximum rate digits, lead zero blanking Total   8 maximum totalizer digits, exponential multipliers from -1 to +6
Units	Feet, gallons, ft <sup>3</sup> , milion-gal, barrels (liquor & oil), acre-feet, lbs., meters, m <sup>3</sup> , liters, milion-liters, kg [Rate time: sec, min, hr, day]
Ambient conditions	0 to +105°F [-20 to +40°C]
Enclosure	NEMA 3 [Type 3] ABS or polycarbonate, CPVC, Ultem, brass or SS hardware, 3W x 6L x 2.5H inches [75W x 150L x 63L mm], pipe mount
Accuracy	±1% of reading at rates above 1 FPS [0.3 MPS]; ±0.01 FPS [.003 MPS] of reading at rates lower than 1 FPS [0.3 MPS]
Response time	3 to 30 seconds, adjustable
Protection	Reverse-polarity, surge suppression
Approvals	General Requirements: ANSI/ISA 582.01; Hazardous Locations: ANSI/ISA 12.12.01 Class I Div 2, Groups C & D
<i>UltraLink</i> software	Windows® based software utility, requires serial communication cable
Transducer type	Clamp-on, uses time of flight ultrasonic
Pipe sizes	½" to 2"
Pipe materials	Carbon steel, stainless steel, brass, and plastic

# PART 1 - TERMINOLOGY

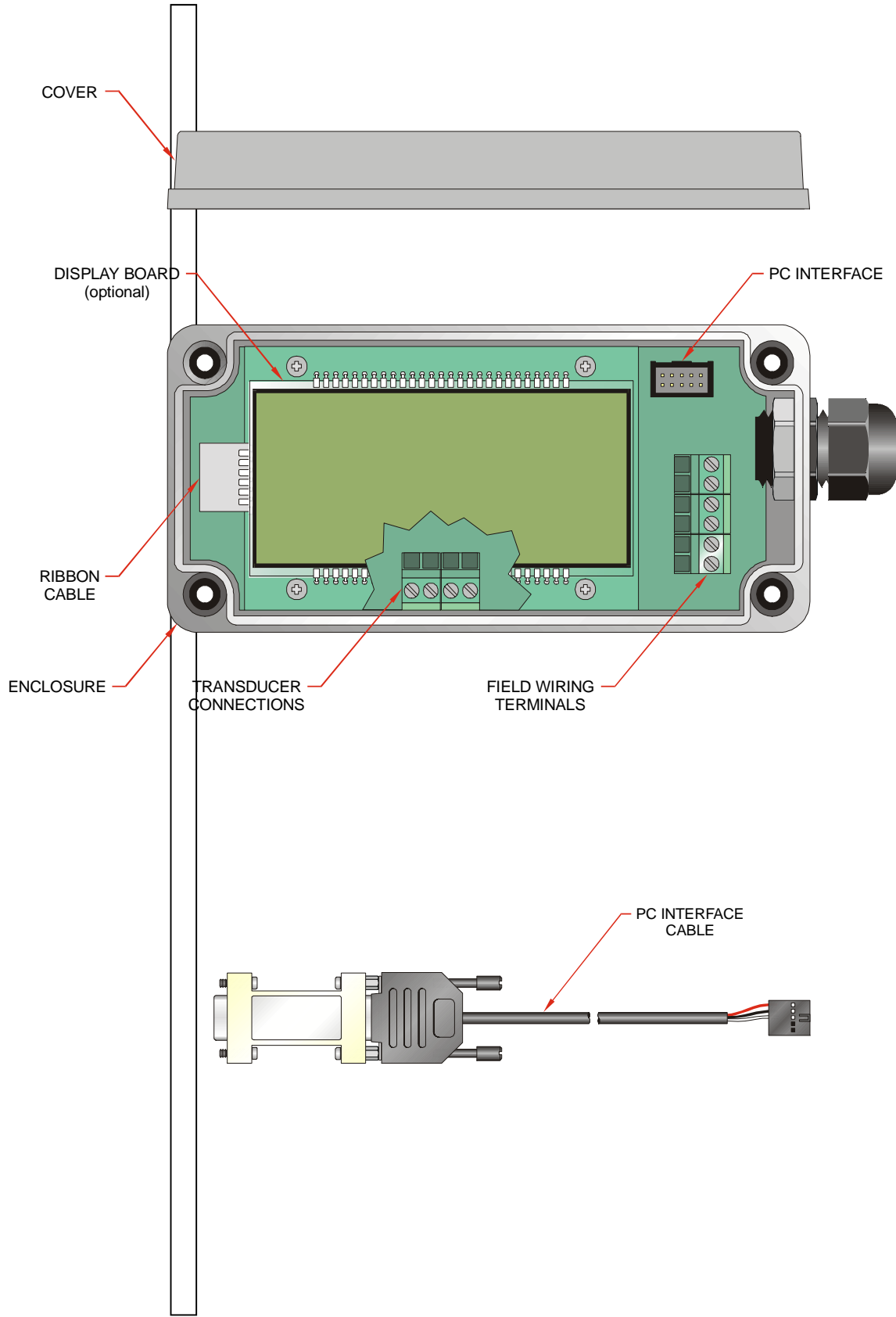

# PART 1 - TRANSMITTER INSTALLATION

## Transmitter Installation

After unpacking, it is recommended to save the shipping carton and packing materials in case the instrument is stored or re-shipped. Inspect the equipment and carton for damage. If there is evidence of shipping damage, notify the carrier immediately.

The enclosure should be mounted in an area that is convenient for servicing, calibration or for observation of the LCD readout.

1. Locate the transmitter within the length of transducer cable that was supplied with the TFXL system. If this is not possible and additional cable is to be added to the transducers, utilize 20 AWG twisted-pair cable. Ensure that both cables are of equal length. If additional cable cannot be added in the field, contact the Dynasonics factory to coordinate an exchange for the proper cable length.
2. Mount the TFXL transmitter in a location that is:
  - ◆ Where little vibration exists.
  - ◆ Protected from falling corrosive fluids.
  - ◆ Within ambient temperature limits -40 to 185°F [-40 to 85°C]
  - ◆ Out of direct sunlight. Direct sunlight may increase temperatures within the transmitter to above the maximum limit.
3. Ensure that enough room is available to allow for maintenance and conduit entrances. Secure the enclosure to a pipe with a 1/2" band clamp.
4. Conduit holes. Conduit hubs should be used where cables enter the enclosure. Holes not used for cable entry should be sealed with plugs.

NOTE: Use NEMA 4 [ IP65 ] rated fittings/plugs to maintain the water tight integrity of the enclosure. Generally, the left conduit hole (viewed from front) is used for line power; the center conduit holes for transducer connections and the right holes are utilized for I/O wiring.

# PART 1 - TRANSMITTER INSTALLATION

## Transducer Connections

To access terminal strips for electronic connectors, loosen the four screws in the display lid and remove the cover. The terminals where the transducer connect is located underneath the display. To connect transducers, remove the four screws that secure the display and carefully move it out of the way. Do not over stress the ribbon cable located between the display and the microprocessor circuit boards.

1. Guide the transducer cables through the transmitter conduit holes located in the bottom of the enclosure. Secure the transducer's flexible conduit with the supplied conduit nut (if flexible conduit was ordered with the transducer) or tighten the cored grip on the coaxial cable.

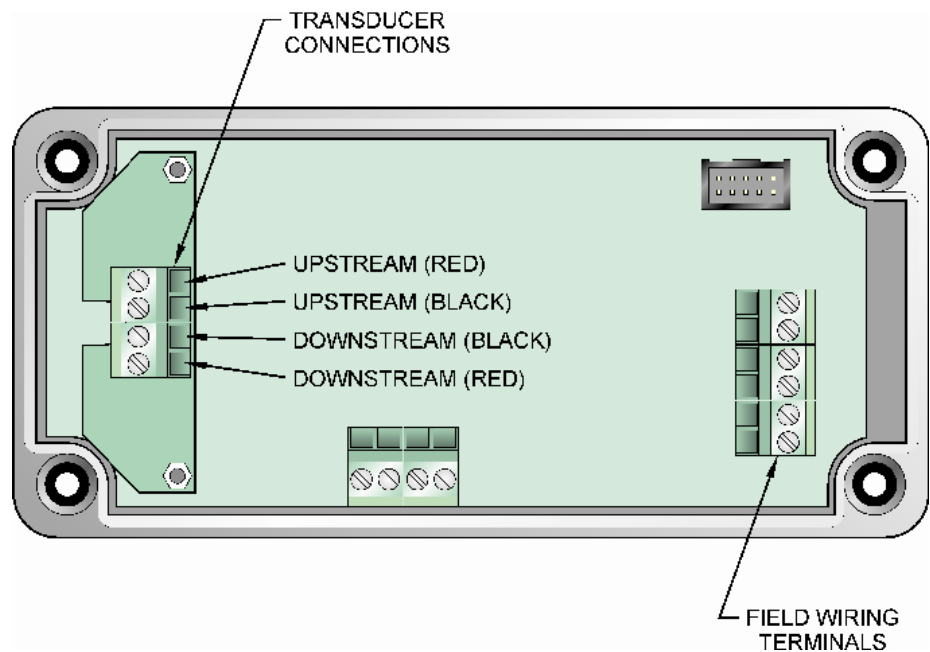

**Figure 1.3**  
**Transducer Connections**

# PART 1 - TRANSMITTER INSTALLATION

## Transmitter Power Connections

2. The terminals within TFXL are a cable-clamp type. Connect the appropriate wires to at the corresponding screw terminals in the transmitter. See **Figure 1.3**. Secure wires by tightening to between 0.5 and 0.6 Nm of torque.

**NOTE:** The transducer cables carry low level signals. It is typically not recommended to add additional cable to the factory supplied coaxial cables. If an exchange is not possible and additional cable is to be added to the transducers, utilize 20 AWG twisted-pair cable. Ensure that both cables are of equal length. If additional cable cannot be added in the field, contact the Dynasonics factory to coordinate an exchange for the proper cable length.

### FIELD WIRING—GENERAL

The TFXL is equipped with a two conduit holes located in the flow meter enclosure that should be suitable for most installations. A sealed cord grip or conduit connection should be utilized to retain the NEMA 3 integrity of the flow meter enclosure. Failure to do so will void the manufactures warranty and can lead to product failure.

Wiring methods and practices are to made in accordance with the NEC—National Electric Code and/or other local ordnances that may be in affect. Consult the local electrical inspector for information regarding wiring regulations.

When making connections to the field wiring terminals inside of the flow meter, strip back the wire insulation approximately 0.25 inches [6 mm]. Stripping back too little may cause the terminals to clamp on the insulation and not make good contact. Stripping back too much insulation may lead to a situation where the wires could short together between adjacent terminals. Wires should be secured in the Field Wiring Terminals using a screw torque of between 0.5 and 0.6 Nm.

## DC Power Supply

### G. FIELD WIRING—POWER

Power for the TFXL flow meter is obtained from a direct current DC power source. The power source should be capable of supplying between 11 and 30 Vdc at a minimum of 0.25 Amps or 250 milliamps. With the power from the DC power source disabled or disconnected, connect the positive supply wire and

# PART 1 - TRANSMITTER INSTALLATION

ground to the appropriate field wiring terminals in the flow meter. See **Figure 1.4**. A wiring diagram decal is located on the inner cover of the flow meter enclosure.



**IMPORTANT NOTE:**

Must be operated by a power supply suitable for the location.



**IMPORTANT NOTE:**

Do not connect or disconnect either power or outputs unless the area is known to be non-hazardous.

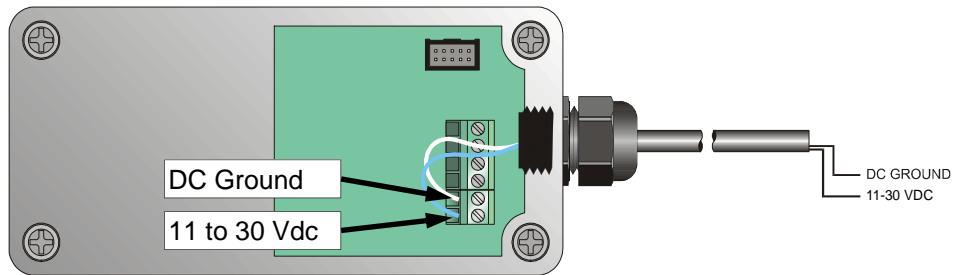

**Figure 1.4**  
**DC Power Connection**

If the flow meter is only to be utilized as a flow rate indicator or totalizer, no further wiring will be required. Skip to Page 1.17.

# PART 1 - INPUT/OUTPUT CONFIGURATION

## Output Configuration

### CONNECTING THE 4-20 mA OUTPUT

The TFXL is equipped with a ground-referenced 4-20 mA output—the output shares a common ground with the power supply. The output transmits a continuous current output that is proportional to liquid flow rate. The output was scaled at the Dynasonics factory and the scaling information is recorded on the label located on the side of the TFXL enclosure. To ensure that the instrument or data acquisition system that is receiving the 4-20 mA signal responds properly, it must be spanned identically to the TFXL.

The 4-20 mA output is designed to source current across a loop resistance that is typically located within a data acquisition system or other receiving instrument. The maximum resistance that the TFXL can accommodate is directly related to the DC power source that is powering the flow meter and the 4-20 mA loop. **Chart 1.1** illustrates the range of load resistance that can be used with a given power supply voltage. Ensure that the loop load resistance is within the shaded region of the graph, or non-linearity and transmitting errors will occur.

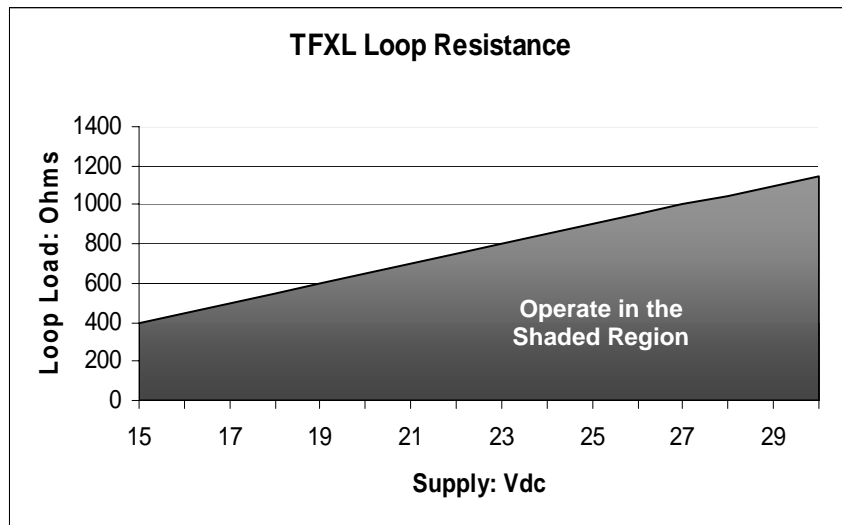

**Chart 1.1**  
**4-20 mA Loop Load**

The 4-20 mA output is polarized and since the output shares the DC common with the power supply, reversing the connections can cause a short circuit in the DC power circuit. **Figure 1.5** shows a block diagram of how the 4-20 mA interfaces with the receiving device.

# PART 1 - INPUT/OUTPUT CONFIGURATION

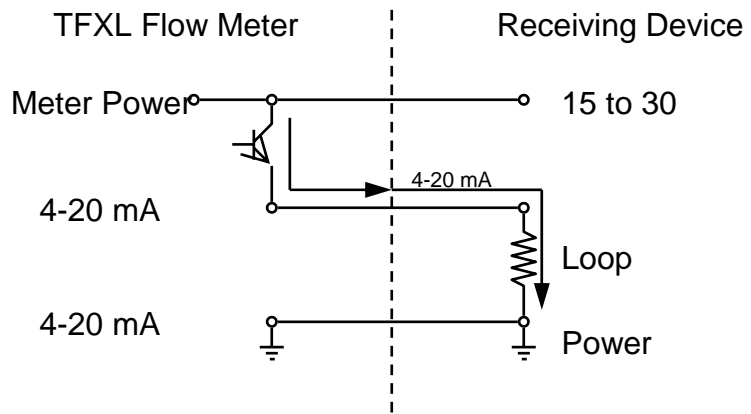

**Figure 1.5**  
4-20 mA Block  
Diagram

Connect the wires to the appropriate Field Wiring Terminals within the TFXL enclosure. See **Figure 1.6**.

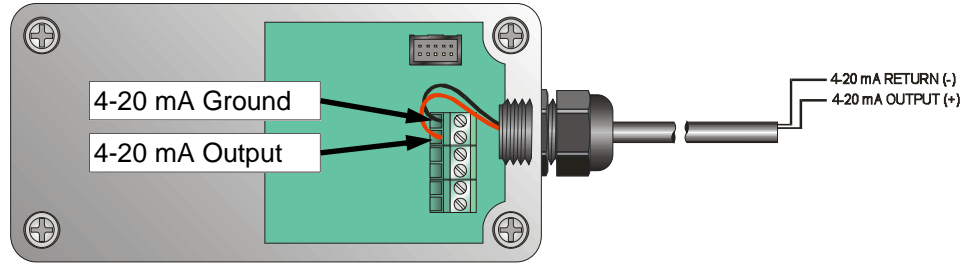

**Figure 1.6**  
4-20 mA Connections

## CONNECTING THE PULSE OUTPUT

The TFXL is equipped with a circuit that outputs a pulse waveform that varies proportionally with flow rate. The quantity of pulses per unit volume of liquid is described by the K-factor that is recorded on the side of the flow meter enclosure. To ensure that accurate readings are being recorded by the receiving instrument, the TFXL and the receiving instrument must have identical K-factor values programmed into them.

Two pulse output options are available with the TFXL:

- ◆ Turbine meter simulation—This option is utilized when a receiving instrument is capable of interfacing directly with a turbine flow meter's magnetic pickup. The output is a relatively low voltage AC signal that is not ground referenced. The minimum AC amplitude is approximately 500 mV peak-to-peak. The TFXL is configured for turbine simulation if the third character after the first dash number in the model number is a "1".
- ◆ TTL pulse frequency—This option is utilized when a receiving instrument requires that the pulse voltage level be either of a higher potential and/or referenced to DC ground. The output is a square-wave with a peak-to-peak voltage swing of 5 volts. The TFXL is configured for TTL pulse frequency if the third character after the first dash number in the model number is a "2".

### Turbine Meter Simulation Output Connection

Connection of the turbine meter simulation output is simply a matter of connecting the two Field Wiring Terminals to the turbine meter input terminals on the receiving instrument and verifying that the K-factor listed on the side of the TFXL enclosure is programmed into the receiving instrument. This output is not referenced to DC ground and is not polarized, so wiring polarity is not important. See **Figure 1.7**.

### TTL Pulse Frequency Connection

Connection of the TTL pulse frequency output is a matter of connecting the two Field Wiring Terminals to the frequency input

# PART 1 - INPUT/OUTPUT CONFIGURATION

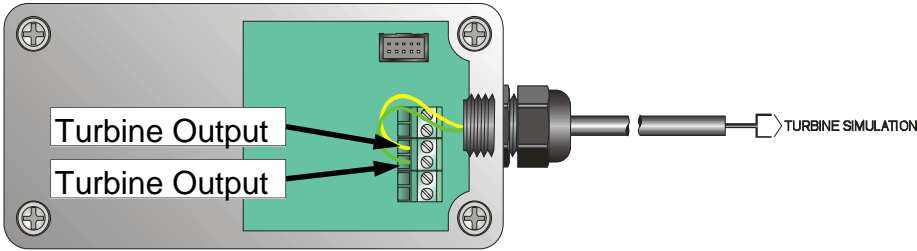

**Figure 1.7**  
**Turbine Meter**  
**Simulation Connections**

terminals on the receiving instrument and verifying that the K-factor listed on the side of the TFXL enclosure is programmed into the receiving instrument. This output is referenced to DC ground and is polarized. Connect the TTL Pulse plus (+) field terminal in the flow meter to the frequency input on the receiving instrument. Connect the TTL Pulse negative (-) field terminal to the frequency input negative or DC common connection in the receiving instrument. See **Figure 1.8**.

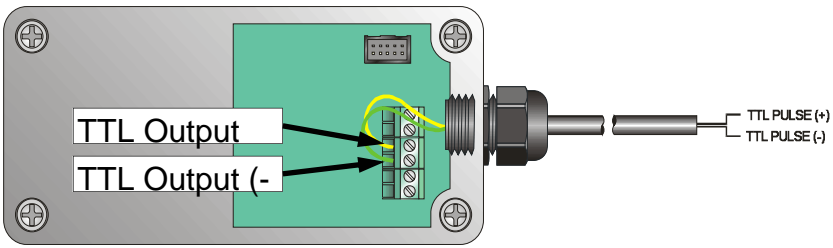

**Figure 1.8**  
**TTL Pulse Output**  
**Connections**

# PART 1 - STARTUP AND CONFIGURATION

## Before Starting the

## Instrument Startup

## Important!

### APPLYING POWER TO THE TFXL

The TFXL flow meter requires a full pipe of liquid before a successful startup can be completed. Do not attempt to make adjustments or change configurations until a full pipe is verified.

1. Verify that all wiring is properly connected and routed as described in Steps A through I of this manual.
2. Verify that the flow sensor is properly mounted and that the acoustic grease is intact between the transducer faces and the pipe.
3. Apply power. The display of the TFXL2 (with a display) will display a display test where all segments will illuminate in succession and then the software version will be displayed. The meter will then enter RUN Mode. If the flow meter is a TFXL1 (without a display) verify that one of the red LEDs on the main printed circuit board is illuminated continuously and that the other one begins to blink.
4. Upon entering RUN Mode, the TFXL2 will provide one of the following responses:
  - ◆ The display may indicate ERROR 0010, which indicates low signal strength. NOTE: ERROR 0010 alternates with the flow totalizer value. Low signal strength is caused by one of the following:
    - ⇒ an empty pipe (gas locked)
    - ⇒ gas content in the liquid is excessive
    - ⇒ inadequate acoustic grease between the flow meter transducer and the pipe
    - ⇒ a broken connection between a transducer and the main circuit board—check wire terminations under the display.
  - ◆ The display may indicate a flow rate.
    - ⇒ If 0.000 is indicated, it means that the meter is operating properly, but that the liquid is not moving.
    - ⇒ A negative value would indicate that flow is moving backwards—against the flow direction arrow. A standard TFXL will not output flow signals under this condition.

## PART 1 - STARTUP AND CONFIGURATION

- ⇒ The flow meter indicates flow rate. This verifies that signal strength is adequate and that the flow is moving in the direction that the flow arrow signifies.

TFXL1 Responses—The TFXL1 is not equipped with a display, so troubleshooting requires the use of a computer and a PC interface cable. See **Section 3** of this manual.

## PART 2 - TRANSDUCER POSITIONING

### General

The transducers that are utilized by the Series TFXL contain piezoelectric crystals for transmitting and receiving ultrasound signals through walls of liquid piping systems. DTTN and DTTH transducers are relatively simple and straight-forward to install, but spacing and alignment of the transducers is critical to the system's accuracy and performance. DTTS, small-pipe transducers have integrated transmitter and receiver elements that eliminate the requirement for spacing measurement and alignment. Extra care should be taken to ensure that these instructions are carefully executed.

Mounting of the DTT clamp-on ultrasonic transit time transducers is comprised of three steps. In general, these steps consist of:

1. Selection of the optimum location on a piping system.
2. Entering the pipe and liquid parameters into either the optional software utility (UltraLink) or keying in the parameters into the TFXL keypad. (TFXL systems that do not have an integral keypad will require the use of UltraLink and a PC computer.) The software embedded in UltraLink and TFXL will calculate proper transducer spacing based on these entries.
3. Pipe preparation and transducer mounting.

### 1. Mounting Location

The first step in the installation process is the selection of an optimum location for the flow measurement to be made. For this to be done effectively, a basic knowledge of the piping system and its plumbing is required.

An optimum location is defined as:

- **A piping system that is completely full of liquid when measurements are being taken.** The pipe may become completely empty during a process cycle—which will result in an error code being displayed on the flow meter while the pipe is empty. Error codes will clear automatically once the pipe refills with liquid. It is not recommended to mount the transducers in a area where the pipe may become partially filled. Partially filled pipes will cause erroneous and unpredictable operation of the meter.
- **A piping system that contains lengths of straight pipe such as those described in Table 2.1.** The optimum straight pipe diameter recommendations apply to pipes in both horizontal and vertical orientation. The straight runs in **Table 2.1** apply to liquid velocities that are nominally 7 FPS [2.2 MPS]. As liquid velocity increases above this nominal rate, the requirement for straight pipe increases proportionally.
- **Mount the transducers in a area where they will not be inadvertently bumped or disturbed during normal operation.**
- **Avoid installations on downward flowing pipes** unless adequate downstream head pressure is present to overcome cavitation in the pipe.

# PART 2 - TRANSDUCER POSITIONING

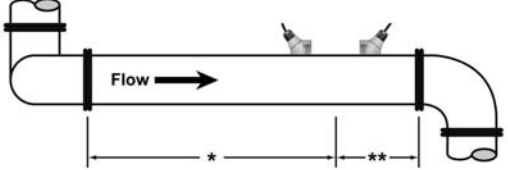
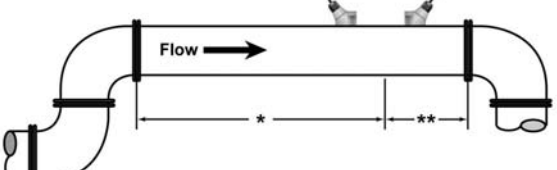
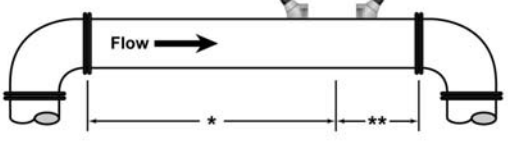
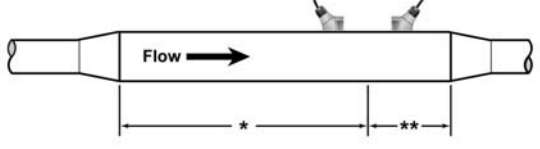
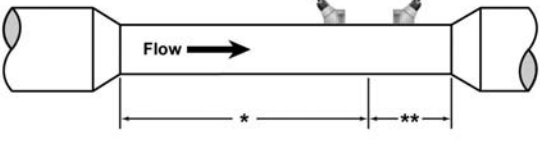
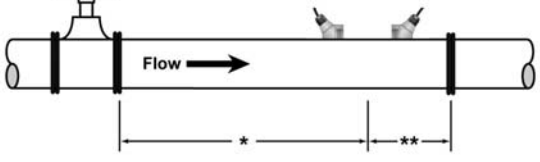
<b>Piping Configuration and Transducer Position</b>	Upstream Pipe Diameters	Downstream Pipe Diameters
	*	**
	24	4
	14	3
	9	3
	8	3
	8	3
	24	4

**Table 2.1  
Straight Pipe Requirements**

## 2. Transducer Spacing

TFXL transit time flowmeters are sold with three different transducer types: DTTN, DTTH and DTTS. Meters that utilize DTTN and DTTH transducers consist of two separate sensors that function as both ultrasonic transmitters and receivers. DTTS transducers integrate both the transmitter and receiver into one assembly that fixes the separation of the piezoelectric elements. DTTN and DTTS transducers are clamped on the outside of a closed pipe **at a specific distance from each other**. The transducers can be mounted in V-mode where the sound transverses the pipe two times, W-mode where the sound transverses the pipe four times, or in Z-mode where the transducers are mounted on opposite sides of the pipe and the sound crosses the pipe once. For further details, reference pictures located under **Table 2.2**. The appropriate mounting configuration is based on pipe and liquid characteristics. Selection of the proper transducer mounting method is not entirely predictable and many times is an iterative process. **Table 2.2** contains recommended mounting configurations for common applications. These recommended configurations may need to be modified for specific applications if such things as aeration, suspended solids or poor piping conditions are present. W-mode provides the longest sound path length between the transducers—but the weakest signal strength. Z-mode provides the strongest signal strength—but has the shortest sound path length. On pipes smaller than 3 inches [75 mm] it is desirable to have a longer path length so that the differential time can be measured more accurately. Use of the TFXL diagnostics in determining the optimum transducer mounting will be covered later in this section.

# PART 2 - TRANSDUCER POSITIONING

**Table 2.2**  
**Transducer Mounting Modes**

Transducer Mount Mode	Pipe Material	Pipe Size	Liquid Composition
<b>W-Mode</b>	Plastic (all types) Carbon Steel Stainless Steel Copper Ductile Iron Cast Iron	1-6 in. (25-150 mm) 1-4 in. (25-100 mm) 1-6 in. (25-150 mm) 1-6 in. (25-150 mm) Not recommended Not recommended	Low TSS; non-aerated Low TSS; non-aerated Low TSS; non-aerated Low TSS; non-aerated
<b>V-Mode</b>	Plastic (all types) Carbon Steel Stainless Steel Copper Ductile Iron Cast Iron	6-30 in. (150-750 mm) 4-24 in. (100-600 mm) 6-30 in. (150-750 mm) 6-30 in. (150-750 mm) 3-12 in. (75-300 mm) 3-12 in. (75-300 mm)	Low TSS; non-aerated Low TSS; non-aerated Low TSS; non-aerated Low TSS; non-aerated Low TSS; non-aerated Low TSS; non-aerated
<b>Z-Mode</b>	Plastic (all types) Carbon Steel Stainless Steel Copper Ductile Iron Cast Iron	> 30 in. (> 750 mm) > 24 in. (> 600 mm) > 30 in. (> 750 mm) > 30 in. (> 750 mm) > 12 in. (> 300 mm) > 12 in. (> 300 mm)	Low TSS; non-aerated Low TSS; non-aerated Low TSS; non-aerated Low TSS; non-aerated Low TSS; non-aerated Low TSS; non-aerated

## Transducer Mounting Modes

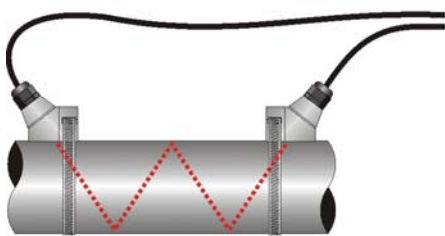

**W-Mount  
Configuration**

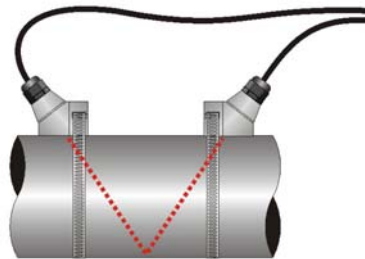

**V-Mount  
Configuration**

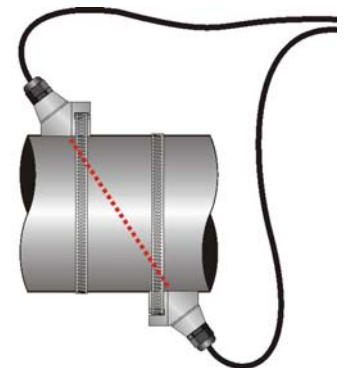

**Z-Mount  
Configuration**

## PART 2 - TRANSDUCER POSITIONING

### Entering Pipe and Liquid Data

**Important!  
Enter All of the  
Data on this  
List , Save the  
Data and Reset  
the TFXL Before  
Mounting  
Transducers**

The TFXL system calculates proper transducer spacing by utilizing piping and liquid information entered by the user. This information is entered via the UltraLink software utility. The software utility and a programming cable are required for programming TFXL instruments.

The following list of information will be required before programming the instrument. Note that much of the data relating to material sound speed, viscosity and specific gravity are preprogrammed into the TFXL flow meter. This data only needs to be modified if it is known that a particular liquid data varies from the reference value. Refer to Section 3 for data entry via UltraLink software.

1. Transducer mounting configuration. See **Table 2.2** on Page 2.5
2. Pipe O.D. (Outside Diameter)
3. Pipe wall thickness
4. Pipe material
5. Pipe sound speed<sup>1</sup>
6. Pipe relative roughness<sup>1</sup>
7. Pipe liner thickness
8. Pipe liner material
9. Pipe liner sound speed<sup>1</sup>
10. Fluid type
11. Fluid sound speed<sup>1</sup>
12. Fluid viscosity<sup>1</sup>
13. Fluid specific gravity<sup>1</sup>

<sup>1</sup>Nominal values for these parameters are included within the TFXL operating system. The nominal values may be used as they appear or may be modified if exact system values are known.

After entering the data listed above, the TFXL will calculate proper transducer spacing for the particular data set. This distance will be in inches if the TFXL is configured in English units and millimeters if configured in metric units.

## 3. Transducer Mounting

After selecting an optimal mounting location (Step 1) and successfully determining the proper transducer spacing (Step 2) the transducers can now be mounted onto the pipe.

The DTTN and DTTH transducers need to be properly oriented on the pipe to provide optimum reliability and performance. On horizontal pipes, the transducers should be mounted 180 radial degrees from one another and at least 45 degrees from the top-dead-center and bottom-dead-center of the pipe. See **Figure 2.1**. Figure 2.1 does not apply to vertically oriented pipes.

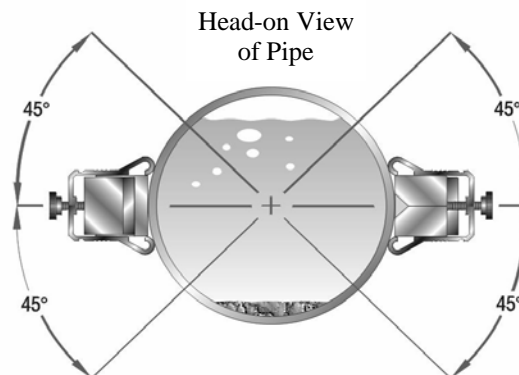

**Figure 2.1**  
**Transducer Orientation—Horizontal Pipes**

DTTS transducers should be mounted with the cable exiting within  $\pm 45^\circ$  of the side of a horizontal pipe. On vertical pipes the orientation does not apply.

Before the transducers are mounted onto the pipe surface, two areas slightly larger than the flat surface of the transducer heads

## PART 2 - TRANSDUCER POSITIONING

### Pipe Preparation

must be cleaned of all rust, scale and moisture. On rough pipe surfaces, such as ductile iron pipe, it is recommended that the pipe surface be ground flat. Paint and other coatings, if not flaked or bubbled, need not be removed. Plastic pipes typically do not require surface preparation other than soap and water cleaning.

Observe Signal Strength while placing the transducers into position. Signal Strength is displayed on the main data screen in UltraLink. See Part 3 of this manual for details regarding the UltraLink software utility.

### V-Mode and W-Mode Installation

1. For DTTN transducers, place a single bead of couplant, approximately 0.5 inch [12 mm] thick, on the flat face of the transducer. See **Figure 2.2**. Generally, a silicone-based grease is used as an acoustic couplant, but any grease-like substance that is rated not to “flow” at the temperature that the pipe may operate at, will be acceptable.
2. Place the upstream transducer in position and secure with a

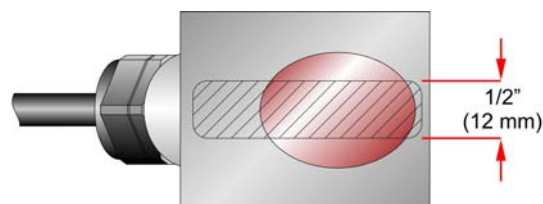

**Figure 2.2**  
**Application of Couplant**

stainless steel strap. Straps should be placed in the arched groove on the end of the transducer. A screw is provided to help hold the transducer onto the strap. Verify that the transducer is true to the pipe—adjust as necessary. Tighten transducer strap securely.

3. Place the downstream transducer on the pipe at the calcu-

## PART 2 - TRANSDUCER POSITIONING

lated transducer spacing. See **Figure 2.3**. Using firm hand pressure, slowly move the transducer both towards and away from the upstream transducer while observing Signal Strength. Clamp the transducer at the position where the highest Signal Strength is observed. Signal Strength of between 3.0 and 95.0 percent is acceptable.

4. If after adjustment of the transducers the Signal Strength

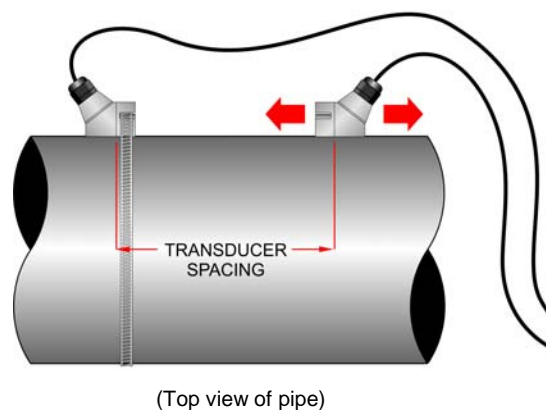

**Figure 2.3**  
**Transducer Position**

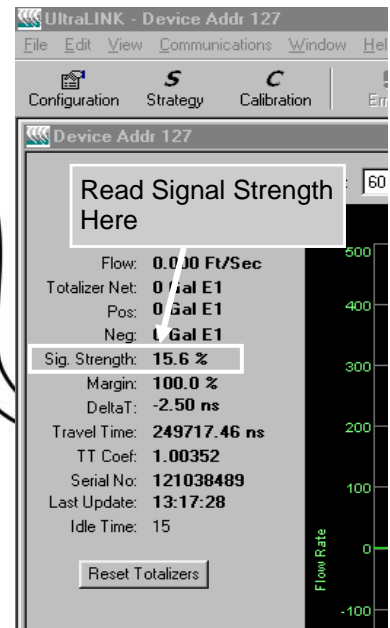

does not rise to above 3.0 percent, then an alternate transducer mounting method should be selected. If the mounting method was W-mode, then reconfigure the TFXL for V-mode, reset the TFXL, move the downstream transducer to the new location and repeat step 3.

5. Certain pipe and liquid characteristics may cause Signal Strength to rise to greater than 95%. The problem with operating a TFXL with very high Signal Strength is that the signals may saturate the input amplifiers and cause erratic readings. To decrease the Signal Strength, move one transducer a small distance radially around the pipe, as shown in **Figure 2.4**.

# PART 2 - TRANSDUCER POSITIONING

## DTTH Transducers For High Temperature

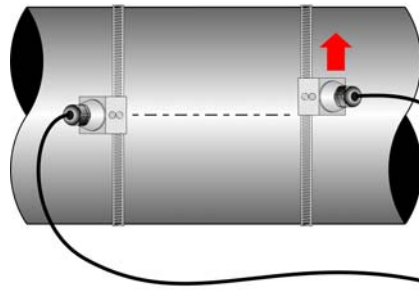

**Figure 2.4**  
**High Signal Strength Condition**

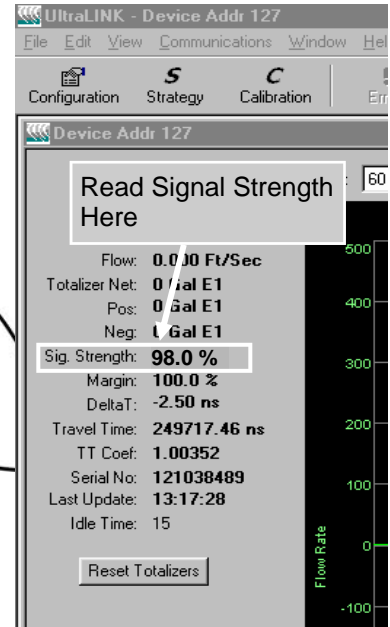

### DTTH High Temperature Transducers

Mounting of high temperature transducers is similar to standard DTTN transducers except that an insulative pad is placed between the transducer and the pipe wall. High temperature installations also require acoustic couplant that is rated not to flow at the temperature that will be present on the pipe surface. **Figure 2.5** should be referenced for insulative pad installation.

Installation of the insulative pads consists of the following steps:

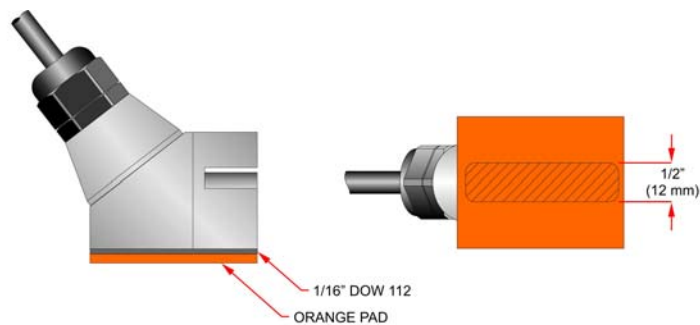

**Figure 2.5**  
**Insulative Pad Installation**

## PART 2 - TRANSDUCER POSITIONING

### DTTS Small Pipe Transducer Installation

1. Apply a thin coating of high temperature grease to the entire surface of the transducer face. The thickness of the application should be approximately 1/16 inch [1.5 mm].
2. Place the orange insulative pad onto the prepared surface of the transducer. Press into place from the center out to remove all air pockets.
3. Apply a 1/2 inch [12 mm] wide bead of grease to the exposed surface of the insulative pad that will contact the pipe.
4. Install the two transducers following the procedures detailed in the DTTN instructions on page 2.8 of this manual.

#### DTTS Small Pipe Transducer Installation

The small pipe transducers offered by Dynasonics are designed for specific pipe outside diameters. Do not attempt to mount a DTTS transducer onto a pipe that is either too large or too small for the transducer—contact the Dynasonics factory to arrange for a replacement transducer that is the correct size.

DTTS installation consists of the following steps:

1. Apply a thin coating of silicone grease to both halves of the transducer housing where the housing will contact the pipe. See **Figure 2.6**.
2. On horizontal pipes, mount the transducer in an orientation such that the cable exits at  $\pm 45^\circ$  from the side of the pipe. Do not mount with the cable exiting on either the top or bottom of the pipe. On vertical pipes the orientation does not matter.
3. Tighten the wingnuts so that the grease begins to flow out from the edges of the transducer and from the gap between the transducer halves. Do not over tighten.
4. If Signal Strength is less than 5%, remount the transducer at another location on the piping system.
5. If Signal Strength is greater than 95%, contact the Dynasonics factory to obtain a lower power Strategy to load into the TFXL flow meter.

## PART 2 - TRANSDUCER POSITIONING

### Mounting Transducers in Z-Mount Configuration

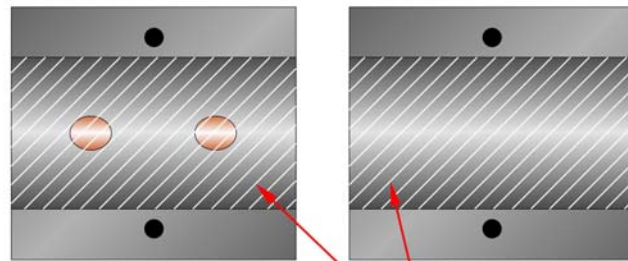

1/16" [1.5mm] MAGNALUBE GREASE

**Figure 2.6**  
**Application of Grease**  
**DTTN Transducer**

### Z-Mode Transducer Installation

Installation on larger pipes requires careful measurements to the linear and radial placement of the DTTN and DTTH transducers. Failure to properly orient and place the transducers on the pipe may lead to weak signal strength and/or inaccurate readings. The section below details a method for properly locating the transducers on larger pipes. This method requires a roll of paper such as freezer paper or wrapping paper, masking tape and a marking device.

1. Wrap the paper around the pipe in the manner shown in **Figure 2.7**. Align the paper ends to within 0.25 inches [6mm].
2. Mark the intersection of the two ends of the paper to indicate the circumference. Remove the template and spread it out on a flat surface. Fold the template in half, bisecting the circumference. See **Figure 2.8**.
3. Crease the paper at the fold line. Mark the crease. Place a mark on the pipe where one of the transducers will be located. See **Figure 2.1** for acceptable radial orientations. Wrap the template back around the pipe, placing the beginning of the paper and one corner in the location of the mark. Move to the other side of the pipe and mark the pipe at the ends of the

## PART 2 - TRANSDUCER POSITIONING

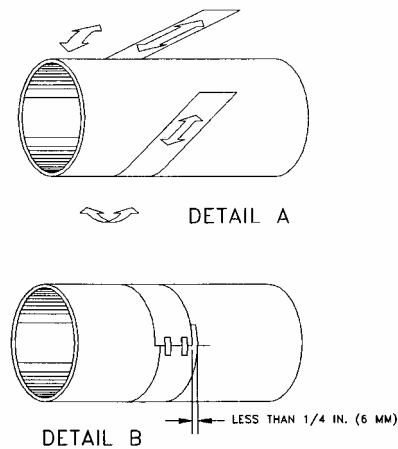

**Figure 2.7**  
**Paper Template Alignment**

crease. Measure from the end of the crease (directly across the pipe from the first transducer location) the dimension derived in Step 2, Transducer Spacing. Mark this location on the pipe.

4. The two marks on the pipe are now properly aligned and measured.

If access to the bottom of the pipe prohibits the wrapping of the paper around the circumference, cut a piece of paper to these dimensions and lay it over the top of the pipe.

Length = Pipe O.D. x 1.57

Width = Spacing determined on page 2.6

Mark opposite corners of the paper on the pipe. Apply transducers to these two marks.

5. For DTTN transducers, place a single bead of couplant, approximately 0.5 inch [12 mm] thick, on the flat face of the transducer. See **Figure 2.2**. Generally, a silicone-based grease is used as an acoustic couplant, but any grease-like substance that is rated to not “flow” at the temperature that the pipe may operate at, will be acceptable.
6. Place the upstream transducer in position and secure with a

## PART 2 - TRANSDUCER POSITIONING

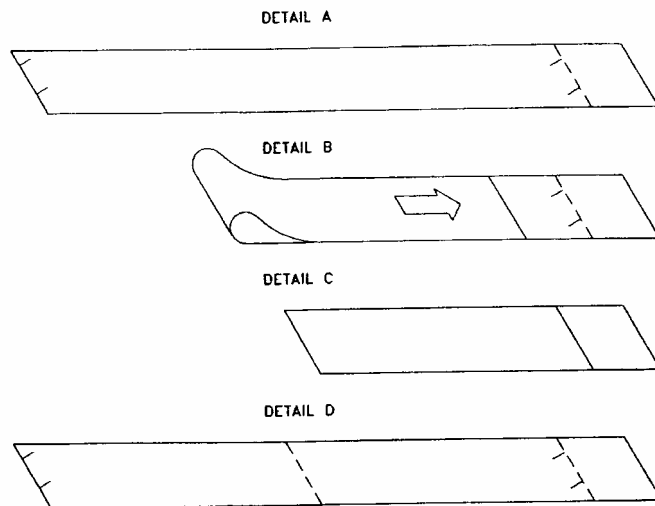
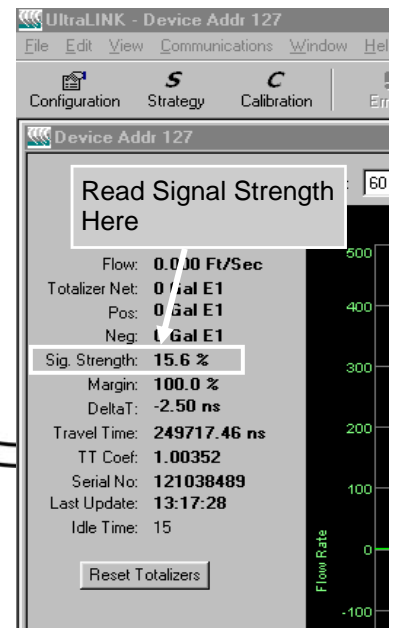
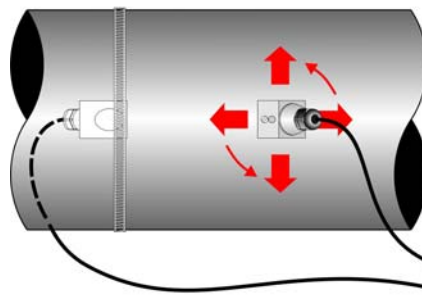

**Figure 2.8**  
**Bisecting the pipe circumference**

stainless steel strap or other. Straps should be placed in the arched groove on the end of the transducer. A screw is provided to help hold the transducer onto the strap. Verify that the transducer is true to the pipe—adjust as necessary. Tighten transducer strap securely. Larger pipes may require more than one strap to reach the circumference of the pipe.

7. Place the downstream transducer on the pipe at the calculated transducer spacing. See **Figure 2.9**. Using firm hand pressure, slowly move the transducer both towards and away from the upstream transducer while observing Signal Strength. Clamp the transducer at the position where the highest Signal Strength is observed. Signal Strength of between 4 and 95 percent is acceptable. On certain pipes, a slight twist to the transducer may cause signal strength to rise to acceptable levels.
8. Certain pipe and liquid characteristics may cause Signal Strength to rise to greater than 95%. The problem with operating a TFXL with very high Signal Strength is that the signals may saturate the input amplifiers and cause erratic readings. To decrease the Signal Strength one transducer can be offset radially, as illustrated in **Figure 2.4**, or a V-Mode transducer mounting method may be chosen.

## PART 2 - TRANSDUCER POSITIONING



**Figure 2.9**  
**Z-Mode Transducer Placement**

9. Secure the transducer with a stainless steel strap or other.

### **D010-2102-010 Mounting Rail Installation**

1. The D010-2102-010 transducer mounting track is used for pipes that have outside diameters between 2 and 10 inches

## PART 2 - TRANSDUCER POSITIONING

### Mounting Rail Installation

- [50-250 mm]. If the pipe is outside of that range then select a standard V-Mode or W-Mode mounting method.
2. Install the single mounting rail on the side of the pipe with the stainless steel bands provided. Do not mount it on the top or bottom of the pipe. Orientation on vertical pipe is not critical. Ensure that the track is parallel to the pipe and that all four mounting feet are touching the pipe.
  3. Slide the two transducer clamp brackets towards the center, 5 inch [125 mm] mark, on the mounting rail.
  4. Place a single bead of couplant, approximately 0.5 inch [12 mm] thick, on the flat face of the transducer. See **Figure 2.2**.
  5. Place the first transducer in between the mounting rails near the zero point on the mounting rail scale. Slide the transducer clamp over the transducer. Adjust the clamp/transducer such that the notch in the clamp aligns with zero on the scale. See **Figure 2.10**.
  6. Secure with the thumb screw. Ensure that the screw rests in the counter bore on the top of the transducer. (Excessive pressure is not required. Apply just enough pressure so that the couplant fills the gap between the pipe and transducer.)

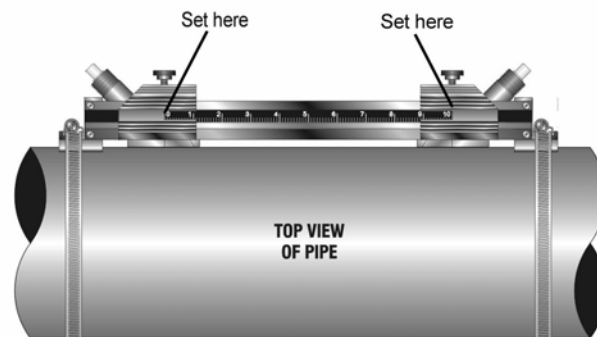

**Figure 2.10**  
**D010-2102-010 Mounting Track Installation**

## PART 2 - TRANSDUCER POSITIONING

---

7. Place the second transducer in between the mounting rails near the dimension derived in the Transducer Spacing section. Read the dimension on the mounting rail scale. Slide the transducer clamp over the transducer and secure with the thumb screw.

# SOFTWARE UTILITY

## Important Notice!

The TFXL flow meter is available with a software utility called **UltraLink**. The UltraLink utility is used for configuration, calibration and communication with the TFXL flow meter.

**UltraLink** has been designed to provide a TFX user a powerful and convenient way to configure and calibrate all TFX flowmeters. UltraLink can be used in conjunction with a PC communications cable—Dynasonics P.N. D010-0204-001.

### System Requirements

Computer type - PC, operating system Windows 95/98/2000/XP, a communications port, hard disk and 3.5" diskette drive.

### Installation

1. Backup/Copy all files from the enclosed disk to a folder on the computer hard disk.
2. Remove the diskette from the computer and store.
3. From the "Start" command, RUN **UISetup.exe** from the hard disk folder.
4. **UISetup** will automatically extract and install on the hard disk and place a short-cut icon on the desktop.
5. Most PCs will require a restart after a successful installation.

### Initialization

1. Connect the PC to the TFX flowmeter using the PC communications cable Dynasonics P.N. D010-0204-001. See **Figure 3.1**.
2. Double-click on the **UltraLink** icon. The first screen is the "RUN-mode" screen, See **Figure 3.2**, which contains real-time information regarding flow rate, totalizer accumulation, system signal strength, diagnostic data and the flow meter's serial number. The indicator in the lower right-hand corner will

# SOFTWARE UTILITY

indicate communications status. If a red **ERROR** is indicated, click on the Communications button on the top bar. Click on Initialize. Choose the appropriate COM port and interface type. Proper communications are established when a green **OK** is indicated in the lower right-hand corner of the PC display.

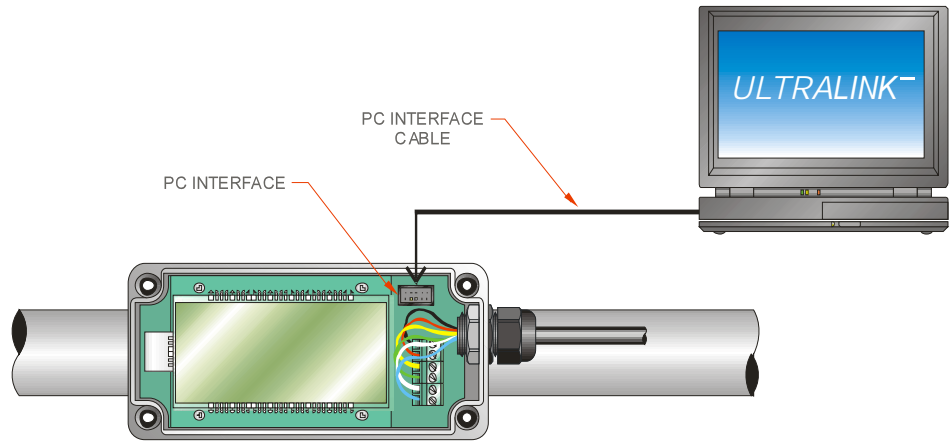

**Figure 3.1**  
**PC Interface Cable Connection**

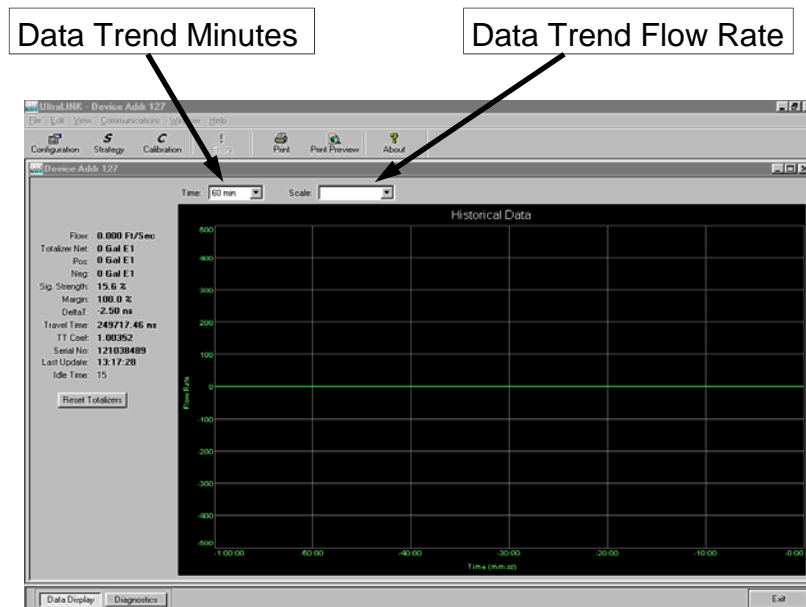
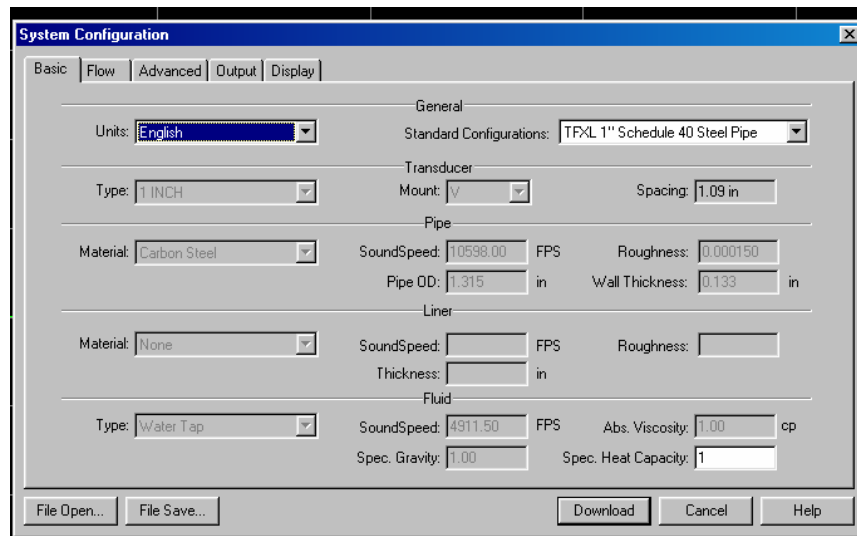

**Figure 3.2**  
**UltraLink Data Screen**

# SOFTWARE UTILITY

## Pipe and Liquid Configuration

Click on the button labeled **Configuration** for updating flow range, liquid, pipe and I/O operating information. The first screen that appears after clicking the **Configuration** button is the **BASIC** tab. See **Figure 3.3**.



**Figure 3.3**  
**Basic Tab**

### 1. **BASIC TAB**—See **Figure 3.3**

- **General Units** allows selection of either English (U.S.) or Metric units of measure. If measurements of the pipe are to be entered in inches, select English. If pipe measurements are to be entered in millimeters, select Metric. It is recommended that if the General Units are altered from those at instrument startup, that the Download button be pressed on the lower right-hand portion of the screen and that the TFXL have its power cycled.
- **Standard Configurations** contains the most popular applications for the TFXL. The TFXL has been constructed and configured at the Dynasonics factory for a specific pipe size. If the Standard Configuration does not match the pipe schedule or material, select the proper configuration from the drop down list. If the pipe schedule is not listed or if the liquid is not water, select **Other** on the drop down list and fill in the proper information on the setup screen.

# SOFTWARE UTILITY

## Flow Units Configuration

### 2. FLOW Tab—See Figure 4.4

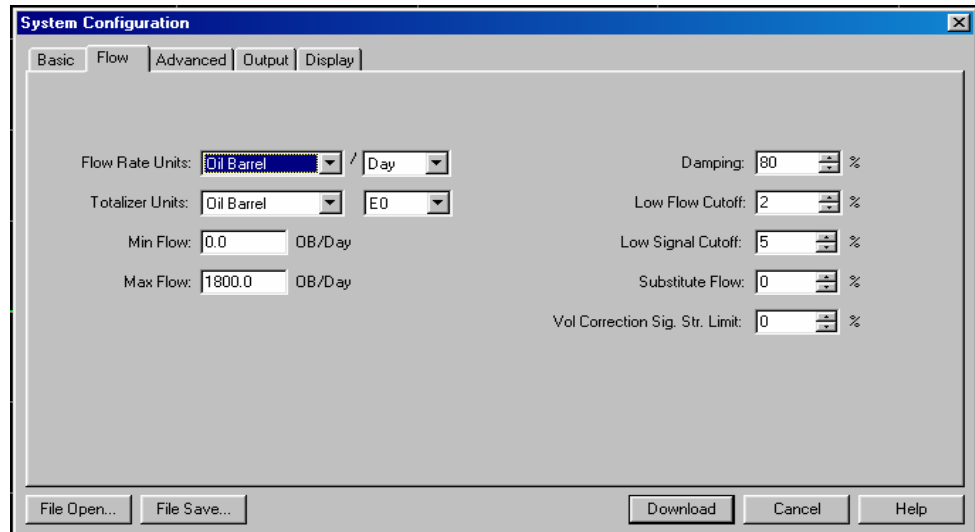

**Figure 3.4**  
**Flow Tab**

- **Flow Rate Units** are selected from the pull down lists. Select an appropriate rate unit and rate time-base from the two lists.
- **Totalizer Units** are selected from pull down lists. Select an appropriate totalizer unit and totalizer exponent. The totalizer exponents are in Scientific Notation and permit the eight digit totalizer to accumulate very large values before the totalizer “rolls over” and starts again at zero. **Table 3.1** illustrates the Scientific Notation values and their respective decimal equivalents.
- **MIN Flow** is used by the TFXL to establish filter settings in its operating system. Enter a flow rate that is the minimum flow rate anticipated within the system. For uni-directional systems, this value is typically zero. For bi-directional systems this value is set to a negative number that is equal to the maximum negative flow rate that is anticipated within the system.
- **MAX Flow** is used by the TFXL to establish filter settings in its operating system. Enter a flow rate that is the maximum, positive flow rate anticipated within the system.
- The **Damping** value is increased to increase stability of the flow

# SOFTWARE UTILITY

**TABLE 3.1—Totalizer Exponent Values**

<b>Exponent</b>	<b>Display Multiplier</b>
<b>E-1</b>	X 1 (No multiplier)
<b>E0</b>	X 1 (No multiplier)
<b>E1</b>	X10
<b>E2</b>	X100
<b>E3</b>	X1,000
<b>E4</b>	X10,000
<b>E5</b>	X100,000
<b>E6</b>	X1,000,000

rate readings. Damping values are decreased to allow the flow meter to react faster to changing flow rates.

- **Low Flow Cutoff** is entered as a percentage between MAX Flow and MIN Flow and influences how the flow meter will act at flows very near zero. Generally, an entry of 1% provides for a stable zero indication, while providing a 100:1 turndown ratio for measurements.
- **Low Signal Cutoff** is a relative value that should be entered after a successful flow meter startup. For an initial value, enter 5% [Signal Strength indications below 3% are considered to be below the noise ceiling and should not be indicative of a successful flow meter startup.] The entry has three purposes: It provides an error indication—Low Signal Strength [Error 0010 on the TFXL display] when liquid conditions within the pipe have changed to the point where flow measurements may not be possible. It warns if the pipe's liquid level has fallen below the level of the transducers. It can also signal that something with the flow meter installation or configuration may have changed. Examples would include such things as the couplant used to mount the transducer has become compromised, a cable has become disconnected or a pipe size setting has been altered.
- **Substitute Flow** is used to provide an indication and output that

# SOFTWARE UTILITY

signifies that an error exists with the flow meter or its setup. It is set as a percentage between MIN Flow and MAX Flow. In a uni-directional system this value is typically set to zero, to indicate zero flow while in an error condition. In a bi-directional system, the percentage can be set such that zero is displayed in a error condition. To calculate out where to set the Substitute Flow value in a bi-directional system perform the following operation:

$$\text{Substitute Flow} = \frac{100 \times \text{MAX Flow}}{\text{MAX Flow} + \text{MIN Flow}}$$

- **Vol. Correction Sig. Str. Limit** is a feature used to provide volumetric compensation for gas bubbles that can present in liquid systems. The TFXL measures the velocity of the liquid in the pipe and converts that velocity to volume by multiplying the velocity by the cross-sectional area of the pipe. If there are gas bubbles within the liquid, the gas is displacing some of the liquid and errors can occur. When Vol. Correction Sig. Str. Limit is set to zero, the compensation function is not operational. To use the feature, enter the maximum Signal Strength observed on the flow meter after installation. The maximum signal strength should occur with the pipe completely full of liquid and the flow stopped. Signal Strength can be observed on the UltraLink Data Screen. See **Figure 3.2**.
- Entry of data in the **Basic** and **Flow** tabs are all that is required to provide flow measurement functions to the flow meter. If the user is not going to utilize input/output functions, click on the **Download** button to transfer the configuration to the TFXL instrument.

## Saving the Configuration

# SOFTWARE UTILITY

## Meter Filter Configuration

### 3. ADVANCED TAB—See Figure 3.5

The Advanced TAB contains several filter settings for the TFXL flow meter. These filters can be adjusted to match response times and data “smoothing” performance to a particular application. The factory settings are suitable for most installations.

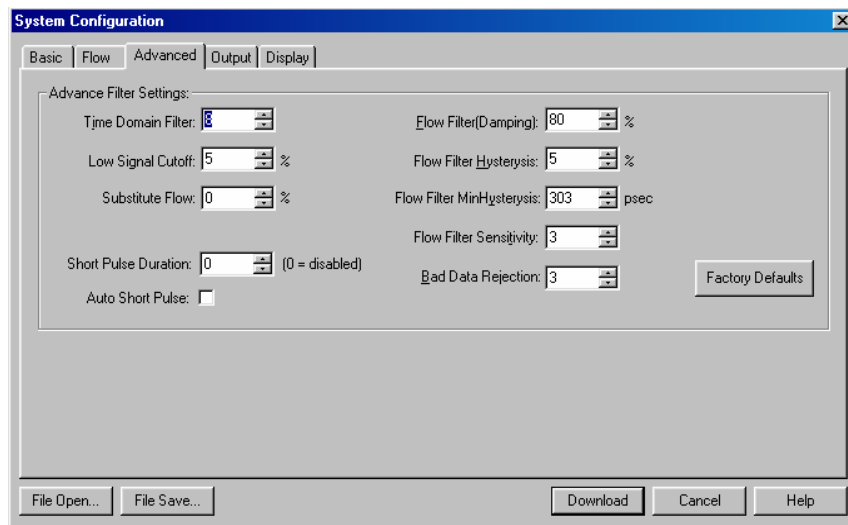

**Figure 3.5**  
**Advanced Tab**

- **Time Domain Filter** adjusts the number of raw data sets (the wave forms viewed on the UltraLink Diagnostics Screen) that are averaged together. Increasing this value will provide greater damping of the data and slow the response time of the flow meter. This filter is not adaptive—it is operational to the value set at all times.
- **Low Signal Cutoff** is a duplicate entry from Page 3.5. Adjusting this value adjusts the value on the Flow TAB.
- **Substitute Flow** is a duplicate entry from Page 3.5. Adjusting this value adjusts the value on the Flow TAB.
- **Short Pulse Duration** is a function used on pipes larger than 8 inches [200 mm]. Set this value to zero to disable the function. This value is factory set and should not be altered.
- **Flow Filter Damping** establishes a maximum adaptive filter value. Under stable flow conditions (flow that varies less than

# SOFTWARE UTILITY

the **Flow Filter Hysteresis** entry) this adaptive filter will increase the number of successive flow readings that are averaged together up to this maximum value. If flow changes outside of the **Flow Filter Hysteresis** window, the Flow Filter adapts by decreasing and allows the meter to react faster. Increasing this value tends to provide smoother steady-state flow readings and outputs.

- **Flow Filter Hysteresis** creates a window around the average flow measurement reading whereby if the flow varies within that window, greater **Flow Filter Damping** will occur. The filter also establishes a flow rate window where measurements outside of the window are captured by the **Bad Data Rejection Filter**. The value is entered as a percentage of actual flow rate.

*Example:*

If the average flow rate is 100 GPM and the Flow Filter Hysteresis is set to 5%, a filter window of 95-105 GPM is established. Successive flow measurements that are measured within that window are recorded and averaged in accordance with the **Flow Filter Damping** setting. Flow readings outside of the window are held up in accordance with the **Bad Data Rejection Filter**.

- **Flow Filter MinHysteresis** sets a minimum hysteresis window that is invoked at low flow rates, where the “of rate” **Flow Filter Hysteresis** is very small and ineffective. This entry is entered in pico-seconds and is differential time. This value is factory set and should not be altered without consulting the Dynasonics technical services department.
- **Flow Filter Sensitivity** allows configuration of how fast the **Flow Filter Damping** will adapt in the positive direction. Increasing this value allows greater damping to occur faster than lower values. Adaptation in the negative direction is not user adjustable.
- **Bad Data Rejection** is a value related to the number of successive readings that must be measured outside of the **Flow Filter Hysteresis** and **Flow Filter MinHysteresis** windows before the flow meter will use that flow value. Larger values are entered into the Bad Data Rejection when measuring liquids that contain gas bubbles, as the gas bubbles tend to disturb the ultrasonic signals and cause more extraneous flow readings to occur. Larger Bad Data Rejection values tend to make the flow meter more sluggish to rapid changes in actual flow rate.

# SOFTWARE UTILITY

## Output Configuration

### Important!

#### 4. Output TAB—See Figure 3.6

The entries made in the Output TAB establish range factors for the 4-20 mA and frequency outputs on the flow meter. The current output is calibrated at the Dynasonics factory and cannot be altered in the field. The range of the output can be altered.

**IMPORTANT:** Configuration should only be performed on Module #1. Module #2 must be left as “None” or communications between the PC and the TFXL will be compromised.

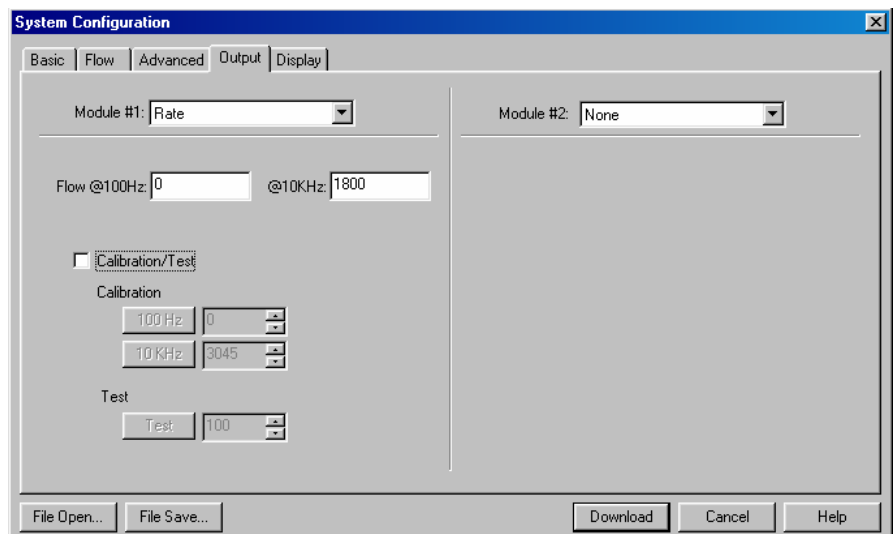

**Figure 3.6**  
**Output Tab**

The label located on the outside of the TFXL enclosure contains information on how the flow meter outputs were configured at the Dynasonics factory. A value that relates flow rate to 4 mA output, flow rate to 20 mA output and K-factor (pulses/gallon) are included on the label. If these factory set values corroborate with those in the data acquisition system that the TFXL is being connected to, no further adjustments are required.

TFXL flow meters are configured at the Dynasonics factory to output a frequency and 4-20 mA signal that are typical for the size of pipe they are being applied to. Altering the K-factor setting will cause the 20 mA setting to change and it will no longer correspond to the value on the TFXL configuration label.

## SOFTWARE UTILITY

To adjust the range of the 4-20 mA output, simply enter the flow rate that corresponds to 4 mA output in the box titled **Flow@100 Hz**, then enter the flow rate corresponding to 20 mA at **@10kHz**. Click the Download button and the new range will be established. The flow rate units must be identical to the Flow Rate Units entered in the Flow TAB—See **Figure 3.4**.

To alter the factory set K-factor setting, two pieces of information must be known—maximum flow rate and desired K-factor. Convert the maximum flow rate to gallons/second, then multiply by the desired K-factor (pulses/gallon). This value equals the maximum frequency output from the flow meter. Multiply this value by four to calculate the value to be entered into the **10 kHz Calibration** box. Press the Download button to save and establish the new K-factor. By altering the factory setting, the 20 mA setting will not be correct.

*Example:*

Maximum Flow Rate = 400 GPM

Desired K-factor = 52 pulses/gallon

6.67 Gallons/second = 400 Gallons/minute

346.67 Hz = 6.67 Gallons/second x 52 pulses/gallon

1,386.67 = 346.67 Hz x 4

Enter 1,387 into the box at **Calibration 10 kHz**

**Note:** An entry of 4,000 in the **Calibration 10 kHz** box will cause an output of 1,000 Hz to occur at full scale flow rate.

# SOFTWARE UTILITY

## Display Configuration

### 5. Display TAB—See Figure 3.7

The Display TAB permits configuration of the flow meter display.

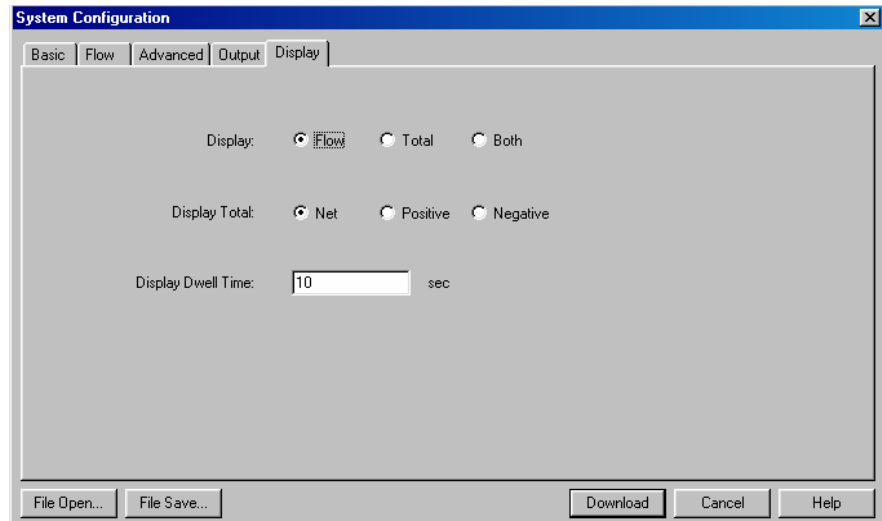

**Figure 3.7**  
**Display Tab**

#### Display

- Select Flow to display flow rate only on the display.
- Select Total to display the flow accumulator only on the display.
- Select Both to periodically toggle between rate and accumulated flow displays.

#### Display Total

- Select Net to display the accumulated difference between the positive and negative totalizers. This feature will subtract backflow (drain back) from the totalizer value.
- Select Positive to display only flows moving in the forward direction.
- Select Negative to display only flows moving in the backwards direction.

#### Display Dwell Time

Enter a value between 1 and 10 seconds to establish how long the flow meter will display flow rate, then accumulated total, then rate and so on.

# SOFTWARE UTILITY

## Flow Meter Calibration

### Setting Zero and Calibration

UltraLink contains a powerful multi-point calibration routine that can be used to calibrate the TFXL flow meter to a primary measuring standard in a particular installation. To initialize the three step calibration routine, press the Calibration button located on the top of the **UltraLink Data Screen**. The display shown in **Figure 3.8** will appear. The first step in the calibration process is the selection of the engineering units that the calibration will be performed with. Select the units and press the Next button at the bottom of the window.

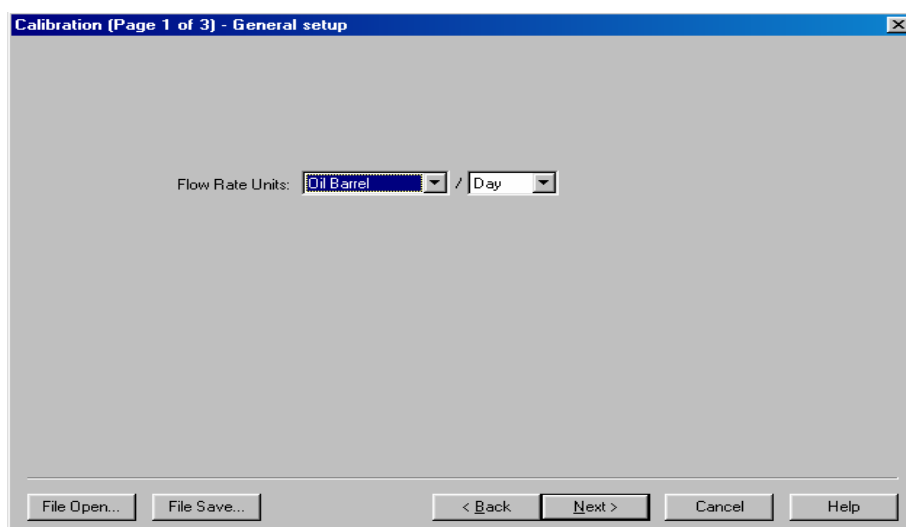

**Figure 3.8**  
**Calibration Units**

The second screen, **Figure 3.9**, establishes a baseline zero flow rate measurement for the instrument. To zero the flow meter, establish zero flow in the pipe (turn off all pumps and close a dead-heading valve). Wait until the delta-time interval shown in **Figure 3.9** is stable (and typically very close to zero). Press the **Set** button. Press the **Next** button when complete, then press the **Finish** button on the Calibration Screen. If the **Set** button was pressed, do not proceed with Flow Rate Calibration before pressing the **Finish** button to save the Zero setting.

# SOFTWARE UTILITY

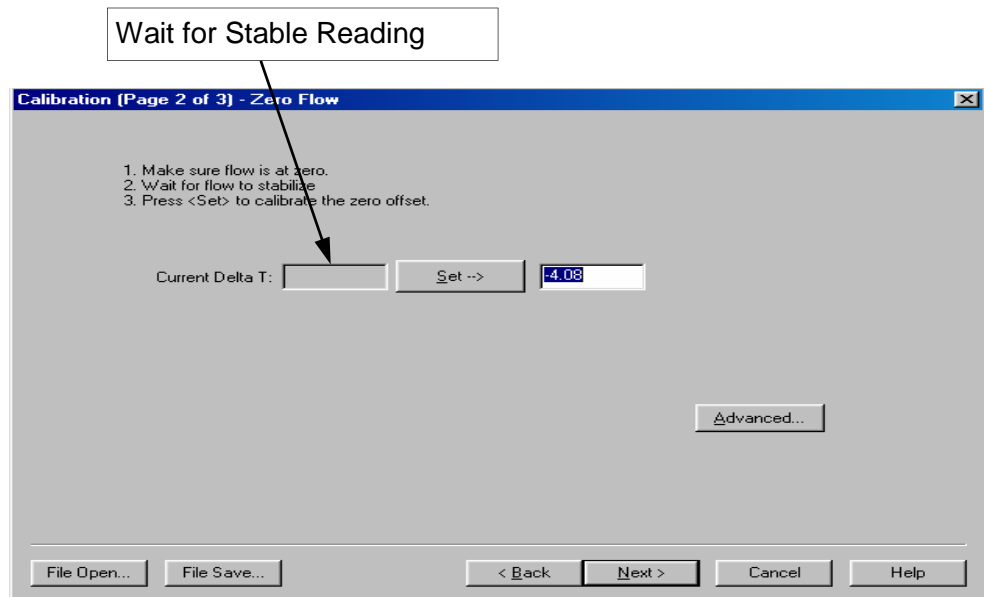
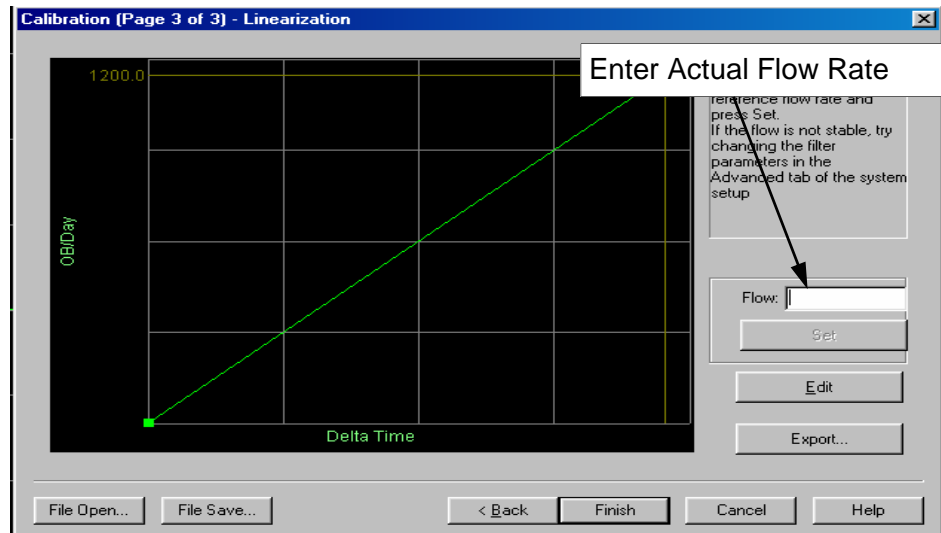

**Figure 3.9**  
**Setting Zero Flow**

The screen shown in **Figure 4.10** allows multiple actual flow rates to be run past the meter and the values recorded by the TFXL. To calibrate a point, establish a stable, known flow rate (verified by a real-time primary flow instrument), enter the actual flow rate in the **Figure 4.10** window and press the **Set** button. Repeat for as many points as desired. Note: If only two points are to be used (zero and span), it is preferred that a flow rate as high as anticipated in normal operation is used as the calibration point. If an erroneous data point is collected, the point can be removed by pressing the **Edit** button, selecting the bad point and selecting Remove.

Press the **Finish** button when all points have been gathered.

# SOFTWARE UTILITY



**Figure 3.10**  
**Flow Rate Calibration**

## **Saving Meter Configuration on a PC**

The complete configuration of the flow meter can be saved from the **Configuration** screen. Select **Save** and name the file. This file may be transferred to other flow meters or may be recalled should the same pipe be surveyed again or multiple meters programmed with the same information.

## **Printing Out a Flow Meter Configuration and Calibration Report**

Select **File** from the upper task bar and **Print** to print out a calibration/configuration information sheet for the flow meter installation.

# **A P P E N D I X**

## Fluid Properties

Original Date: 7/30/1999  
 Revision: A  
 Revision Date: 9/10/2003  
 File: I:/dynasonics/dyna\_code/tables/fluid\_ss.xls

Fluid	Specific Gravity 20 degrees C	Sound Speed m/s	ft/s	delta-v/degree C m/s/degree C	Kinematic Viscosity Centistokes	Absolute Viscosity Centipoise
Acetate, Butyl		1270	4163.9			
Acetate, Ethyl	0.901	1085	3559.7	4.4	0.489	0.441
Acetate, Methyl	0.934	1211	3973.1		0.407	0.380
Acetate, Propyl		1280	4196.7			
Acetone	0.79	1174	3851.7	4.5	0.399	0.316
Alcohol	0.79	1207	3960.0	4.0	1.396	1.101
Alcohol, Butyl	0.83	1270	4163.9	3.3	3.239	2.688
Alcohol, Ethyl	0.83	1180	3868.9	4	1.396	1.159
Alcohol, Methyl	0.791	1120	3672.1	2.92	0.695	0.550
Alcohol, Propyl		1170	3836.1			
Alcohol, Propyl	0.78	1222	4009.2		2.549	1.988
Ammonia	0.77	1729	5672.6	6.7	0.292	0.225
Aniline	1.02	1639	5377.3	4.0	3.630	3.710
Benzene	0.88	1306	4284.8	4.7	0.711	0.625
Benzol, Ethyl	0.867	1338	4389.8		0.797	0.691
Bromine	2.93	889	2916.7	3.0	0.323	0.946
n-Butane	0.60	1085	3559.7	5.8		
Butyrate, Ethyl		1170	3836.1			
Carbon dioxide	1.10	839	2752.6	7.7	0.137	0.151
Carbon tetrachloride	1.60	926	3038.1	2.5	0.607	0.968
Chloro-benezene	1.11	1273	4176.5	3.6	0.722	0.799
Chloroform	1.49	979	3211.9	3.4	0.550	0.819
Diethyl ether	0.71	985	3231.6	4.9	0.311	0.222
Diethyl Ketone		1310	4295.1			
Diethylene glycol	1.12	1586	5203.4	2.4		
Ethanol	0.79	1207	3960.0	4.0	1.390	1.097
Ethyl alcohol	0.79	1207	3960.0	4.0	1.396	1.101
Ether	0.71	985	3231.6	4.9	0.311	0.222
Ethyl ether	0.71	985	3231.6	4.9	0.311	0.222
Ethylene glycol	1.11	1658	5439.6	2.1	17.208	19.153
Freon R12		774.2	2540			
Gasoline	0.7	1250	4098.4			
Glycerin	1.26	1904	6246.7	2.2	757.100	953.946
Glycol	1.11	1658	5439.6	2.1		
Isobutanol	0.81	1212	3976.4			
Iso-Butane		1219.8	4002			
Isopentane	0.62	980	3215.2	4.8	0.340	0.211
Isopropanol	0.79	1170	3838.6		2.718	2.134
Isopropyl alcohol	0.79	1170	3838.6		2.718	2.134
Kerosene	0.81	1324	4343.8	3.6		
Linalool		1400	4590.2			
Linseed Oil	.925-.939	1770	5803.3			
Methanol	0.79	1076	3530.2	2.92	0.695	0.550
Methyl alcohol	0.79	1076	3530.2	2.92	0.695	0.550
Methylene chloride	1.33	1070	3510.5	3.94	0.310	0.411
Methylethyl Ketone		1210	3967.2			
Motor Oil (SAE 20/30)	.88-.935	1487	4875.4			
Octane	0.70	1172	3845.1	4.14	0.730	0.513

Oil, Castor	0.97	1477	4845.8	3.6	0.670	0.649
Oil, Diesel	0.80	1250	4101			
Oil (Lubricating X200)		1530	5019.9			
Oil (Olive)	0.91	1431	4694.9	2.75	100.000	91.200
Oil (Peanut)	0.94	1458	4783.5			
Paraffin Oil		1420	4655.7			
Pentane	0.626	1020	3346.5		0.363	0.227
Petroleum	0.876	1290	4229.5			
1-Propanol	0.78	1222	4009.2			
Refrigerant 11	1.49	828.3	2717.5	3.56		
Refrigerant 12	1.52	774.1	2539.7	4.24		
Refrigerant 14	1.75	875.24	2871.5	6.61		
Refrigerant 21	1.43	891	2923.2	3.97		
Refrigerant 22	1.49	893.9	2932.7	4.79		
Refrigerant 113	1.56	783.7	2571.2	3.44		
Refrigerant 114	1.46	665.3	2182.7	3.73		
Refrigerant 115		656.4	2153.5	4.42		
Refrigerant C318	1.62	574	1883.2	3.88		
Silicone (30 cp)	0.99	990	3248		30.000	29.790
Toluene	0.87	1328	4357	4.27	0.644	0.558
Transformer Oil		1390	4557.4			
Trichlorethylene		1050	3442.6			
1,1,1-Trichloro-ethane	1.33	985	3231.6		0.902	1.200
Turpentine	0.88	1255	4117.5		1.400	1.232
Water, distilled	0.996	1498	4914.7	-2.4	1.000	0.996
Water, heavy	1	1400	4593			
Water, sea	1.025	1531	5023	-2.4	1.000	1.025
Wood Alcohol	0.791	1076	3530.2	2.92	0.695	0.550
m-Xylene	0.868	1343	4406.2		0.749	0.650
o-Xylene	0.897	1331.5	4368.4	4.1	0.903	0.810
p-Xylene		1334	4376.8		0.662	

# TFX Error Codes

Revised 2-22-2002

Code Number	Description	Correction
<b>Warnings</b>		
0001	Serial number not present	Hardware serial number has become inoperative – system performance will not be influenced.
0010	Signal Strength is below Signal Strength Cutoff entry	Low signal strength is typically caused by one of the following: ? Empty pipe ? Improper programming/incorrect values ? Improper transducer spacing ? Non-homogeneous pipe wall
0011	Measured Speed of Sound the in the liquid is greater than 10% different than the value entered during meter setup	Verify that the correct liquid was selected in the BASIC menu. Verify that pipe size parameters are correct.
0020	Heat Flow Units of measure have been selected and an RTD module has not been installed	Verify that RTD Module PN D020-1045-106 has been installed in one of the I/O meter slots. Verify that OUTPUT1 or OUTPUT 2 has been configured for RTD measurements.
<b>Class C Errors</b>		
1001	System tables have changed	Initiate a meter RESET by cycling power or by selecting SYSTEM RESET in the SEC MENU.
1002	System configuration has changed	Initiate a meter RESET by cycling power or by selecting SYSTEM RESET in the SEC MENU.
<b>Class B Errors</b>		
3001	Invalid hardware configuration	Upload corrected file
3002	Invalid system configuration	Upload corrected file
3003	Invalid strategy file	Upload corrected file
3004	Invalid calibration data	Recalibrate the system
3005	Invalid speed of sound calibration data	Upload new data
3006	Bad system tables	Upload new table data
3007	Data Logger is off or not present	If desired, insert data logger and configure within the Datalog Operations Menu. If logger is not present, configure I/O port for no logger.
3010	One or more channels are not responding (Multi-channel meters only)	Display indicates which secondary units are not communicating with Master meter. Verify wiring, configuration and address of secondary instrument.
3011	All channels are not responding (Multi-channel meters only)	Verify wiring, configuration and address of secondary instruments.
<b>Class A Errors</b>		
4001	Flash memory full	Return unit to factory for evaluation



## Cast Iron Pipe

### Standard Classes

Size (Inches)	CLASS A			CLASS B			CLASS C			CLASS D			CLASS E			CLASS F			CLASS G			CLASS H			
	O.D. Inch	I.D. Inch	Wall	O.D. Inch	I.D. Inch	Wall	O.D. Inch	I.D. Inch	Wall	O.D. Inch	I.D. Inch	Wall	O.D. Inch	I.D. Inch	Wall	O.D. Inch	I.D. Inch	Wall	O.D. Inch	I.D. Inch	Wall	O.D. Inch	I.D. Inch	Wall	
3	3.80	3.02	0.39	3.96	3.12	0.42	3.96	3.06	0.45	3.96	3.00	0.48													
4	4.80	3.96	0.42	5.00	4.10	0.45	5.00	4.04	0.48	5.00	3.96	0.52													
6	6.90	6.02	0.44	7.10	6.14	0.48	7.10	6.08	0.51	7.10	6.00	0.55	7.22	6.06	0.58	7.22	6.00	0.61	7.38	6.08	0.65	7.38	6.00	0.69	
8	9.05	8.13	0.46	9.05	8.03	0.51	9.30	8.18	0.56	9.30	8.10	0.60	9.42	8.10	0.66	9.42	8.10	0.66	9.60	8.10	0.75	9.60	8.00	0.8	
10	11.10	10.10	0.50	11.10	9.96	0.57	11.40	10.16	0.62	11.40	10.04	0.68	11.60	10.12	0.74	11.60	10.00	0.80	11.84	10.12	0.86	11.84	10.00	0.92	
12	13.20	12.12	0.54	13.20	11.96	0.62	13.50	12.14	0.68	13.50	12.00	0.75	13.78	12.14	0.82	13.78	12.00	0.89	14.08	12.14	0.97	14.08	12.00	1.04	
14	15.30	14.16	0.57	15.30	13.98	0.66	15.65	14.17	0.74	15.65	14.01	0.82	15.98	14.18	0.90	15.98	14.00	0.99	16.32	14.18	1.07	16.32	14.00	1.16	
16	17.40	16.20	0.60	17.40	16.00	0.70	17.80	16.20	0.80	17.80	16.02	0.89	18.16	16.20	0.98	18.16	16.00	1.08	18.54	16.18	1.18	18.54	16.00	1.27	
18	19.50	18.22	0.64	19.50	18.00	0.75	19.92	18.18	0.87	19.92	18.00	0.96	20.34	18.20	1.07	20.34	18.00	1.17	20.78	18.22	1.28	20.78	18.00	1.39	
20	21.60	20.26	0.67	21.60	20.00	0.80	22.06	20.22	0.92	22.06	20.00	1.03	22.54	20.24	1.15	22.54	20.00	1.27	23.02	20.24	1.39	23.02	20.00	1.51	
24	25.80	24.28	0.76	25.80	24.02	0.89	26.32	24.22	1.05	26.32	24.00	1.16	26.90	24.28	1.31	26.90	24.00	1.45	27.76	24.26	1.75	27.76	24.00	1.88	
30	31.74	29.98	0.88	32.00	29.94	1.03	32.40	30.00	1.20	32.74	30.00	1.37	33.10	30.00	1.55	33.46	30.00	1.73							
36	37.96	35.98	0.99	38.30	36.00	1.15	38.70	35.98	1.36	39.16	36.00	1.58	39.60	36.00	1.80	40.04	36.00	2.02							
42	44.20	42.00	1.10	44.50	41.94	1.28	45.10	42.02	1.54	45.58	42.02	1.78													
48	50.50	47.98	1.26	50.80	47.96	1.42	51.40	47.98	1.71	51.98	48.00	1.99													
54	56.66	53.96	1.35	57.10	54.00	1.55	57.80	54.00	1.90	58.40	53.94	2.23													
60	62.80	60.02	1.39	63.40	60.06	1.67	64.20	60.20	2.00	64.82	60.06	2.38													
72	75.34	72.10	1.62	76.00	72.10	1.95	76.88	72.10	2.39																
84	87.54	84.10	1.72	88.54	84.10	2.22																			



## Ductile Iron Pipe

### Standard Classes

Pipe Size (inches)	Outside Diameter (inches)	Class 50		Class 51		Class 52		Class 53		Class 54		Class 55		Class 56		Cement Lining Std./Double Thickness
		ID	Wall	ID	Wall	ID	Wall	ID	Wall	ID	Wall	ID	Wall	ID	Wall	
3	3.96			3.46	0.25	3.40	0.28	3.34	0.31	3.28	0.34	3.22	0.37	3.14	0.41	.123/.250
4	4.80			4.28	0.26	4.22	0.29	4.16	0.32	4.10	0.35	4.04	0.38	3.93	0.44	
6	6.90	6.40	0.25	6.34	0.28	6.28	0.31	6.22	0.34	6.16	0.37	6.10	0.40	6.04	0.43	
8	9.05	8.51	0.27	8.45	0.30	8.39	0.33	8.33	0.36	8.27	0.39	8.21	0.42	8.15	0.45	
10	11.10	10.32	0.39	10.46	0.32	10.40	0.35	10.34	0.38	10.28	0.41	10.22	0.44	10.16	0.47	
12	13.20	12.58	0.31	12.52	0.34	12.46	0.37	12.40	0.40	12.34	0.43	12.28	0.46	12.22	0.49	
14	15.30	14.64	0.33	14.58	0.36	14.52	0.39	14.46	0.42	14.40	0.45	14.34	0.48	14.28	0.51	.1875/.375
16	17.40	16.72	0.34	16.66	0.37	16.60	0.40	16.54	0.43	16.48	0.46	16.42	0.49	16.36	0.52	
18	19.50	18.80	0.35	18.74	0.38	18.68	0.41	18.62	0.44	18.56	0.47	18.50	0.50	18.44	0.53	
20	21.60	20.88	0.36	20.82	0.39	20.76	0.42	20.70	0.45	20.64	0.48	20.58	0.51	20.52	0.54	
24	25.80	25.04	0.38	24.98	0.41	24.92	0.44	24.86	0.47	24.80	0.50	24.74	0.53	24.68	0.56	
30	32.00	31.22	0.39	31.14	0.43	31.06	0.47	30.98	0.51	30.90	0.55	30.82	0.59	30.74	0.63	.250/.500
36	38.30	37.44	0.43	37.34	0.48	37.06	0.62	37.14	0.58	37.40	0.45	36.94	0.68	36.84	0.73	
42	44.50	43.56	0.47	43.44	0.53	43.32	0.59	43.20	0.65	43.08	0.71	42.96	0.77	42.84	0.83	
48	50.80	49.78	0.51	49.64	0.58	49.50	0.65	49.36	0.72	49.22	0.79	49.08	0.86	48.94	0.93	
54	57.10	55.96	0.57	55.80	0.65	55.64	0.73	55.48	0.81	55.32	0.89	55.16	0.97	55.00	1.05	



## Steel, Stainless Steel, P.V.C.

### Standard Schedules

Nominal Pipe Size Inches	OUTSIDE DIAMETER	SCH. 5		SCH. 10 (LTWALL)		SCH. 20		SCH. 30		STD.		SCH. 40		SCH. 60		X STG.		SCH. 80		SCH. 100		SCH. 120		SCH. 140		SCH. 180			
		ID	Wall	ID	Wall	ID	Wall	ID	Wall	ID	Wall	ID	Wall	ID	Wall	ID	Wall	ID	Wall	ID	Wall	ID	Wall	ID	Wall	ID	Wall		
1	1.315	1.185	0.065	1.097	0.109					1.049		1.049	0.133			0.957	0.179	0.957	0.179									0.815	0.250
1.25	1.660	1.530	0.065	1.442	0.109					1.380		1.380	0.140			1.278	0.191	1.278	0.191									1.160	0.250
1.5	1.900	1.770	0.065	1.682	0.109					1.610		1.610	0.145			1.500	0.200	1.500	0.200									1.338	0.281
2	2.375	2.245	0.065	2.157	0.109					2.067		2.067	0.154			1.939	0.218	1.939	0.218									1.687	0.344
2.5	2.875	2.709	0.083	2.635	0.120					2.469		2.469	0.203			2.323	0.276	2.323	0.276									2.125	0.375
3	3.500	3.334	0.083	3.260	0.120					3.068		3.068	0.216			2.900	0.300	2.900	0.300									2.624	0.438
3.5	4.000	3.834	0.083	3.760	0.120					3.548		3.548	0.226			3.364	0.318	3.364	0.318										
4	4.500	4.334	0.083	4.260	0.120					4.026	0.237	4.026	0.237			3.826	0.337	3.826	0.337				3.624	0.438	3.624	0.438	3.438	0.531	
5	5.563	5.345	0.109	5.295	0.134					5.047	0.258	5.047	0.258			4.813	0.375	4.813	0.375				4.563	0.500	4.563	0.500	4.313	0.625	
6	6.625	6.407	0.109	6.357	0.134					6.065	0.280	6.065	0.280			5.761	0.432	5.761	0.432				5.501	0.562	5.501	0.562	5.187	0.719	
8	8.625	8.407	0.109	8.329	0.148	8.125	0.250	8.071	0.277	7.981	0.322	7.981	0.322	7.813	0.406	7.625	0.500	7.625	0.500	7.437	0.594	7.187	0.719	7.187	0.719	6.183	1.221		
10	10.750	10.482	0.134	10.42	0.165	10.25	0.250	10.13	0.310	10.02	0.365	10.020	0.365	9.750	0.500	9.750	0.500	9.562	0.594	9.312	0.719	9.062	0.844	9.062	0.844	8.500	1.125		
12	12.750	12.420	0.165	12.39	0.180	12.25	0.250	12.09	0.330	12.00	0.375	11.938	0.406	11.626	0.562	11.750	0.500	11.370	0.690	11.060	0.845	10.750	1.000	10.750	1.000	10.120	1.315		
14	14.000			13.50	0.250	13.37	0.315	13.25	0.375	13.25	0.375	13.124	0.438	12.814	0.593	13.000	0.500	12.500	0.750	12.310	0.845	11.810	1.095	11.810	1.095	11.180	1.410		
16	16.000			15.50	0.250	15.37	0.315	15.25	0.375	15.25	0.375	15.000	0.500	14.688	0.656	15.000	0.500	14.310	0.845	13.930	1.035	13.560	1.220	13.560	1.220	12.810	1.595		
18	18.000			17.50	0.250	17.37	0.315	17.12	0.440	17.25	0.375	16.876	0.562	16.564	0.718	17.000	0.500	16.120	0.940	15.680	1.160	15.250	1.375	15.250	1.375	14.430	1.785		
20	20.000			19.50	0.250	19.25	0.375	19.25	0.375	19.25	0.375	18.814	0.593	18.376	0.812	19.000	0.500	17.930	1.035	17.430	1.285	17.000	1.500	17.000	1.500	16.060	1.970		
24	24.000			23.50	0.250	23.25	0.375	23.25	0.375	23.25	0.375	22.626	0.687	22.126	0.937	23.000	0.500	21.560	1.220	20.930	1.535	20.930	1.535	20.930	1.535	19.310	2.345		
30	30.000			29.37	0.315	29.00	0.500	29.00	0.500	29.25	0.375	29.250	0.375			29.000	0.500												
36	36.000			35.37	0.315	35.00	0.500	35.00	0.500	35.25	0.375	35.250	0.375			35.000	0.500												
42	42.000									41.25	0.375	41.250	0.375			41.000	0.500												
48	48.000									47.25	0.375	47.250	0.375			47.000	0.500												



**FPS TO GPM CROSS - REFERENCE (Schedule 40)**

Nominal Pipe (Inches)	I.D. INCH	1	1.5	2	2.5	3	3.5	4	4.5	5	5.5	6	6.5	7	7.5	8	8.5	9
1	1.05	2.6989	4.0484	5.3978	6.7473	8.097	9.4462	10.796	12.145	13.490	14.844	16.190	17.540	18.890	20.240	21.590	22.941	24.290
1.25	1.38	4.6620	6.9929	9.3239	11.655	13.99	16.317	18.648	20.979	23.310	25.641	27.970	30.300	32.630	34.960	37.300	39.627	41.958
1.5	1.61	6.3454	9.5182	12.691	15.864	19.04	22.209	25.382	28.555	31.730	34.900	38.070	41.250	44.420	47.590	50.760	53.936	57.109
2	2.07	10.489	15.734	20.979	26.224	31.47	36.713	41.958	47.202	52.450	57.692	62.940	68.180	73.430	78.670	83.920	89.160	94.405
2.5	2.47	14.935	22.402	29.870	37.337	44.80	52.272	59.740	67.207	74.670	82.142	89.610	97.080	104.50	112.00	119.50	126.95	134.41
3	3.07	23.072	34.608	46.144	57.680	69.22	80.752	92.288	103.82	115.40	126.90	138.40	150.00	161.50	173.00	184.60	196.11	207.65
3.5	3.55	30.851	46.276	61.702	77.127	92.55	107.98	123.40	138.83	154.30	169.68	185.10	200.50	216.00	231.40	246.80	262.23	277.66
4	4.03	39.758	59.636	79.515	99.394	119.3	139.15	159.03	178.91	198.80	218.67	238.50	258.40	278.30	298.20	318.10	337.94	357.82
5	5.05	62.430	93.645	124.86	156.07	187.3	218.50	249.72	280.93	312.10	343.36	374.60	405.80	437.00	468.20	499.40	530.65	561.87
6	6.06	89.899	134.85	179.80	224.75	269.7	314.65	359.60	404.55	449.50	494.45	539.40	584.30	629.30	674.20	719.20	764.14	809.09
8	7.98	155.89	233.83	311.78	389.72	467.7	545.61	623.56	701.50	779.40	857.39	935.30	1013.0	1091.0	1169.0	1247.0	1325.1	1403.0
10	10.02	245.78	368.67	491.56	614.45	737.3	860.23	983.12	1106.0	1229.0	1351.8	1475.0	1598.0	1720.0	1843.0	1966.0	2089.1	2212.0
12	11.94	348.99	523.49	697.99	872.49	1047.0	1221.5	1396.0	1570.5	1745.0	1919.5	2094.0	2268.0	2443.0	2617.0	2792.0	2966.5	3141.0
14	13.13	422.03	633.04	844.05	1055.1	1266.0	1477.1	1688.1	1899.1	2110.0	2321.1	2532.0	2743.0	2954.0	3165.0	3376.0	3587.2	3798.2
16	15.00	550.80	826.20	1101.6	1377.0	1652.0	1927.8	2203.2	2478.6	2754.0	3029.4	3305.0	3580.0	3856.0	4131.0	4406.0	4681.8	4957.2

FPS TO GPM:  $GPM = (PIPE\ ID)^2 \times VELOCITY\ IN\ FPS \times 2.45$

GPM TO FPS:  $FPS = \frac{GPM}{(ID)^2 \times 2.45}$

FPS X .3048 = MPS

GPM X .0007 = GPD

GPM X 3.7878 = LPM



## FPS TO GPM CROSS - REFERENCE (Schedule 40)

Nominal Pipe (Inches)	I.D. INCH	1	1.5	2	2.5	3	3.5	4	4.5	5	5.5	6	6.5	7	7.5	8	8.5	9
18	16.88	697.52	1046.3	1395.0	1743.8	2093.0	2441.3	2790.1	3138.8	3488.0	3836.3	4185.0	4534.0	4883.0	5231.0	5580.0	5928.9	6277.7
20	18.81	866.14	1299.0	1732.0	2165.3	2598.4	3031.5	3464.6	3897.6	4330.7	4763.8	5196.8	5629.9	6063.0	6496.0	6929.1	7362.2	7795.3
24	22.63	1253.7	1880.0	2507.0	3134.1	3761.0	4387.8	5014.6	5641.5	6268.3	6895.1	7522.0	8148.8	8775.6	9402.4	10029	10656	11283
26	25.25	1560.7	2341.0	3121.0	3901.9	4682.2	5462.6	6243.0	7023.4	7803.7	8584.1	9364.5	10145	10925	11706	12486	13266	14047
28	27.25	1817.8	2727.0	3636.0	4544.5	5453.4	6362.3	7271.2	8180.0	9088.9	9997.8	10907	11816	12725	13633	14542	15451	16360
30	29.25	2094.4	3142.0	4189.0	5236.0	6283.2	7330.4	8377.6	9424.9	10472	11519	12566	13614	14661	15708	16755	17803	18850
32	31.25	2390.6	3586.0	4781.0	5976.5	7171.9	8367.2	9562.5	10758	11953	13148	14344	15539	16734	17930	19125	20320	21516
34	33.25	2706.4	4060.0	5413.0	6766.0	8119.2	9472.4	10826	12179	13532	14885	16238	17592	18945	20298	21651	23004	24358
36	35.25	3041.8	4563.0	6084.0	7604.5	9125.4	10646	12167	13688	15209	16730	18251	19772	21292	22813	24334	25855	27376
42	41.25	4165.4	6248.0	8331.0	10414	12496	14579	16662	18744	20827	22910	24992	27075	29158	31241	33323	35406	37489
48	47.99	5637.8	8457.0	11276	14095	16913	19732	22551	25370	28189	31008	33827	36646	39465	42284	45103	47922	50740
54	53.98	7133.1	10700	14266	17833	21399	24966	28532	32099	35665	39232	42798	46365	49931	53498	57065	60631	64198
60	60.09	8839.2	13259	17678	22098	26518	30937	35357	39777	44196	48616	53035	57455	61875	66294	70714	75134	79553
72	72.10	12726	19089	25451	31814	38177	44540	50903	57266	63628	69991	76354	82717	89080	95443	101805	108168	114531
84	84.10	17314	25971	34628	43285	51943	60600	69257	77914	86571	95228	103885	112542	121199	129856	138514	147171	155828

FPS TO GPM:  $GPM = (PIPE\ ID)^2 \times VELOCITY\ IN\ FPS \times 2.45$

GPM TO FPS:  $FPS = \frac{GPM}{(ID)^2 \times 2.45}$

FPS X .3048 = MPS

GPM X .0007 = GPD

GPM X 3.7878 = LPM

## Limited Warranty and Disclaimer

Dynasonics, div. of Racine Federated Inc. warrants to the end purchaser, for a period of one year from the date of shipment from our factory, that all new transmitters and transducers manufactured by it are free from defects in materials and workmanship. This warranty does not cover products that have been damaged due to normal use, misapplication, abuse, lack of maintenance, or improper installation. Dynasonics' obligation under this warranty is limited to the repair or replacement of a defective product, at no charge to the end purchaser, if the product is inspected by Dynasonics and found to be defective. Repair or replacement is at Dynasonics' discretion. An authorization number must be obtained from Dynasonics before any product may be returned for warranty repair or replacement. The product must be thoroughly cleaned and any process chemicals removed before it will be accepted for return.

The purchaser must determine the applicability of the product for its desired use and assumes all risks in connection therewith. Dynasonics assumes no responsibility or liability for any omissions or errors in connection with the use of its products. Dynasonics will under no circumstances be liable for any incidental, consequential, contingent or special damages or loss to any person or property arising out of the failure of any product, component or accessory.

All expressed or implied warranties, including **the implied warranty of merchantability and the implied warranty of fitness for a particular purpose or application are expressly disclaimed** and shall not apply to any products sold or services rendered by Dynasonics.

The above warranty supersedes and is in lieu of all other warranties, either expressed or implied and all other obligations or liabilities. No agent or representative has any authority to alter the terms of this warranty in any way.

## **GENERAL TERMS AND CONDITIONS OF SALES**

1. **PAYMENT** – Terms of payment are effective from the actual date of invoice. If, in the Seller's opinion, the financial condition of the Buyer at any time – or any other circumstances – do not justify the incurrence of production costs of shipment on the terms of payment specified, the Seller may require partial or full payment in advance. Payment terms are net 30 days unless otherwise stated on invoice.
2. **F.O.B.** – All shipments are from Racine, Wisconsin, USA, unless otherwise other stated, and title transfers to the buyer upon leaving factory.
3. **QUOTATION AND PRICES** – Quoted prices are firm for 30 days unless stated in the quotation and are subject to change without notice after expiration of this period.
4. **TAXES** – Any applicable sales, use, revenue, excise or other taxes not specifically stated in the quotation are to be remitted by the Buyer directly to the appropriate regulatory agency.
5. **WARRANTY** – Seller's standard published warranty in effect at the time of shipment shall apply. This warranty is exclusive and is in lieu of all other warranties, express, implied, or statutory, including the warranty of merchantability.
6. **DELIVERY** – The Seller shall not be liable for loss or damage of any kind resulting from delay or inability to deliver on account of flood, fire, labor trouble, riots, civil disturbances, accidents, acts or orders or regulations of civil or military authorities, shortages of material, or any other causes beyond Seller's control.
7. **PRODUCT CHANGES** – In keeping with our continuing policy of product improvement, we reserve the right to make changes in our products at any time, without incurring an obligation to change, replace or upgrade equipment previously shipped.
8. **CANCELLATIONS** – An order placed by Buyer and accepted by Seller may be cancelled only with the Seller's consent and upon terms that will indemnify the Seller against loss.
9. **RESTOCKING CHARGE** – On standard equipment, the charge is 25%, provided the equipment is returned within 30 days in acceptable condition with a RGA number. Restocking charges for special equipment may vary from standard equipment, and will be handled on a case-by-case basis. No returns will be taken after one year.

## RETURN OF EQUIPMENT/SALES INFORMATION

### CONTACTS AND PROCEDURES

#### Customer Service/Application Engineer:

If you have a question regarding order status, placing an order, reviewing applications for future purchases, or wish to purchase a new flowmeter, please contact our new National Sales and Marketing Headquarters:

DYNASONICS  
Division of Racine Federated, Inc.  
8635 Washington Avenue  
Racine, WI 53406  
PHONE: (800)535-3569 or  
(262)639-6770  
FAX: (262)639-2267

#### Service/Repair Department:

If you already purchased equipment and have an operation problem, require service, or need to schedule field service, please contact our Service Department:

DYNASONICS  
Division of Racine Federated, Inc.  
8635 Washington Avenue  
Racine, WI 53406  
PHONE: (800)535-3569 or  
(262)639-6770  
FAX: (262)639-2267

#### Return Goods Authorization:

When returning equipment, it is necessary for you to contact our Service Department at (800)535-3569 or (262)639-6770 to obtain an RGA number for the authority and proper tracking of your material and its prompt inspection and return. The RGA number should be noted on the outside of the box. All returns of equipment go to the following address:

DYNASONICS  
Division of Racine Federated, Inc.  
8635 Washington Avenue  
Racine, WI 53406  
Attn: RGA #



8635 WASHINGTON AVENUE  
RACINE, WI 53406

TOLL-FREE IN NORTH AMERICA.:

TEL: (800) 535-3569 FAX: (800) 732-8354

TEL: (262) 639-6770 FAX: (262) 639-2267

URL: [www.dynasonics.com](http://www.dynasonics.com)